



# Special Provisions



Local Public Agency	County	Section Number
City of Princeton	Bureau	GEN FUNDS

The following Special Provision supplement the "Standard Specifications for Road and Bridge Construction", adopted

January 1, 2022, the latest edition of the "Manual on Uniform Traffic Control Devices for Streets and Highways", and the "Manual of Test Procedures of Materials" in effect on the date of invitation of bids, and the Supplemental Specification and Recurring Special Provisions indicated on the Check Sheet included here in which apply to and govern the construction of the above named section, and in case of conflict with any parts, or parts of said Specifications, the said Special Provisions shall take precedence and shall govern.

**LOCATION OF PROJECT**

This project is located in the City of Princeton, Illinois on Various Streets within the City Limits.

**PRE-QUALIFICATION**

Pre-Qualification is required to bid this project.

**DESCRIPTION OF PROJECT**

Work includes Hot-Mix Asphalt resurfacing of Various Streets including HMA Surface Removal (Cold Milling), HMA Binder Course, Bituminous Hot Mix Sand Seal, Manhole Adjustments and related items.

**HMA SURFACE REMOVAL, 2-1/4" & HMA SURFACE REMOVAL BUTT-JOINT**

This work shall be done in accordance with the appropriate articles of Section 406 and 440 of the Standard Specifications.

Removal shall be done in accordance with the typical sections shown on the plans or as directed by the Engineer and shall consist of removing existing HMA or Portland Cement Concrete patches from the pavement structure to the depth specified or as according to the Engineer to insure a proper finished cross slope. No payment will be made for additional HMA Binder Course or HMA Surface Course to correct unauthorized additional depth of milling.

Any area within the project limits that cannot be reached by the milling machine is to be removed by other means. This will include areas at headers and butt joints, areas around manholes and valves, and along the curb and gutter. At all limits of the milling, a clean, full width joint shall be saw cut and material removed to obtain a clean, straight edge to the depth of milling. This removal will be considered incidental to the milling operation and no other payment will be made.

All grindings shall be stockpiled in an area designated by the City of Princeton and shall become property of the City.

**MANHOLES TO BE ADJUSTED, SPECIAL**

This work consists of the adjusting of existing manhole frames and lids to the finished surface. Cast iron rings will NOT be permitted to make adjustments.

The contractor shall remove the frames and lids prior to or after the milling operation, plate the manhole with suitable steel plating to support traffic and fill the resulting void with cold patch. Prior to placement of the binder course and surface course the Contractor shall remove the cold patch material and fill any resulting voids with leveling binder material. After placement of the surface course the Contractor shall core

City of Princeton

Bureau

GEN FUNDS

the pavement above the manhole, remove the plate and reset the existing manhole frame and grate using metal shims and bituminous rope. Should any frame or grate be in poor condition, the Contractor shall notify the Engineer and/or Streets Superintendent and the City shall supply the Contractor with replacement materials prior to adjustment. The frame shall be set at an elevation level with the adjacent HMA surface course and the voids around the frame filled with Portland Cement Concrete to the elevation of the HMA surface course and broom finished. The Contractor shall protect the work with appropriate traffic control devices.

This work shall be measured and paid for at the Contract Unit Price per EACH of MANHOLES TO BE ADJUSTED, SPECIAL.

INLETS TO BE ADJUSTED, SPECIAL

This work consists of the adjusting of existing inlet frames and lids to the finished grade.

The contractor shall remove 5 LF of curb or curb & gutter on each side of the existing inlet. Make adjustments as necessary to match proposed edge of pavement or pavement and replace curb or curb & gutter. Contractor shall adjust the elevation of inlet frame to provide proper drainage from curb flow-lines. Frames shall be frames shall be completely grouted at inlet structure and frame.

No additional payments will be made for curb or curb & gutter removal and replacement and shall be incidental to INLET TO BE ADJUSTED, SPECIAL pay item.

This work shall be measured and paid for at the Contract Unit Price per EACH of INLETS TO BE ADJUSTED, SPECIAL.

WATER

Water required by the Contractor for milling machines and rollers shall not be obtained from fire hydrants. If necessary, water can be obtained from the City at their direction.

WORK NOTIFICATION

At least 24 hours prior to working on a street, the fire and police departments and City Street Department shall be notified. Residents in the limits of the project shall be notified by fliers and notices on barricades provided by the Contractor. Notifications shall be considered incidental to the Contract and no additional payment will be made.

STREET CLOSURES

During construction associated with this project, no street closures will be allowed. Traffic control shall be provided to maintain traffic flow through the operation.

TRAFFIC CONTROL & PROTECTION

Implementation and maintenance shall be in accordance with IDOT Standards and as directed by the Engineer. Cost of Traffic Control & Protection shall be incidental to HMA binder and surface courses.

State of Illinois  
DEPARTMENT OF TRANSPORTATION  
Bureau of Local Roads and Streets  
SPECIAL PROVISION  
FOR  
BITUMINOUS HOT MIX SAND SEAL COAT

Effective August 1, 1969  
Revised January 1, 2007

All references to Sections or Articles in this specification shall be construed to mean a specific Section or Article of the Standard Specifications for Road and Bridge Construction, adopted by the Department of Transportation.

Description. This item shall consist of the furnishing and spreading of a bituminous hot mix sand seal coat mixture to a compacted thickness of 19 mm (0.75 inch) or less all in accordance with the requirements of these specifications, and to the lines, grade, thickness and cross sections shown on the plans or established by the Engineer.

Materials. Materials shall meet the requirements of the following Articles of Section 1000 - Materials.

Item	Article/Section
(a) Fine Aggregate (Note 1) .....	1003.03 (a, b)
(b) Coarse Aggregate (Note 2) .....	1004.03 (a, b)
(c) Bituminous Materials (Note 3) .....	1032.01-1032.03, 1032.05, 1032.06, 1032.08

Note 1. The fine aggregate shall be of gradation FA-1. Stone sand shall not be permitted.

If approved by the Engineer, the material may be produced by blending aggregates from more than one source. The method of blending shall be by the use of aggregate feeders of the apron, drum, reciprocating, or other type approved by the Engineer, which shall provide for proportional and total feeding of the aggregates. The components of a blend need not be of the same kind of material. The source of material and blending proportions shall not be changed during the progress of the work without written permission from the Engineer.

Note 2. The coarse aggregate shall be of gradation CA-16.

Note 3. The contractor may use any one of the types of bituminous materials as shown in the table below. When more than one grade is shown for particular mixture, the Engineer reserves the right to specify the grade that shall be used.

Type of Construction	Bituminous Material
Prime Coat	MC-30 PEP
Bituminous Hot Mix Sand Seal Coat	MC-3000 RS-1, RS-2, HFE-90, HFE-150 PG 46-28, PG 52-28, PG 58-28, PG 58-22

Equipment. The following required items of equipment shall conform to Section 1100 - Equipment:

Item	Article/Section
(a) Tandem Rollers .....	1101.01 (e)(1)
(b) Three-wheel Rollers .....	1101.01 (e)(2)
(c) Hot Mix Plant .....	1102.01
(d) Spreading and Finishing Machine .....	1102.03

### CONSTRUCTION REQUIREMENTS

General. The seal coat mixture shall be laid only on a base which is dry and only when weather conditions are suitable. No mixture shall be laid when the temperature of the air in the shade is below 10 °C (50 °F). No work shall be started if local conditions indicate rain is imminent.

Rolling shall be done with three-wheel and tandem rollers. The rollers shall weigh 7 to 11 metric tons (8 to 12 tons).

All surfaces shall be cleaned of dirt, debris, and loose material prior to placing the bituminous mixture.

Preparation of Base. When an existing bituminous concrete pavement is to be sealed, all excess crack filler and bituminous patches that contain an excess of bitumen or which are unstable in hot weather shall be removed. All bitumen shall be removed from cracks more than 38 mm (1.5 inches) wide. The Contractor shall perform this work in the most economical manner practicable and as directed by the Engineer. All waste material placed on the shoulders during the pavement cleaning operations shall be removed at the close of each day's work and shall be disposed of outside the limits of the right-of-way at locations acceptable to the Engineer. This work will be paid for in accordance with Article 109.04.

Prior to placing the seal coat mixture, all open cracks having a width of 13 mm (0.5 inch) or more, cracks that have been cleaned and depressions of 25 mm (1 inch) or more in the existing pavement or base, shall be completely filled with a bituminous mixture meeting the approval of the Engineer.

The mixture shall be tamped in place with hand tools. This work shall be completed at least 24 hours prior to placing the seal coat mixture.

Preparation of Aggregate and Bituminous Materials. The bituminous material for the prime coat, if required by the Engineer, shall be prepared according to Article 403.07 and applied according to Articles 403.10 and 403.11.

The aggregate and bituminous materials shall be heated to the following temperatures:

	Aggregate	Bituminous Material
Emulsified Bituminous Mixture	Not to exceed 150 °C (300 °F)	60 to 80 °C (140 to 180 °F)
Liquid Bituminous Mixture	Not to exceed 110 °C (225 °F)	Not to exceed 65 °C (150 °F)
Asphalt Cement Mixture	135 to 190 °C (275 to 375 °F)	120 to 180 °C (250 to 350 °F)

Preparation of Seal Coat Mixture. The heated aggregate and the bituminous material for the seal coat mixture shall be measured separately and accurately by weight. The bituminous mixture shall be made in the pug mill mixer. The bituminous material shall be added to the hot aggregate in less than 15 seconds. The wet mixing period shall produce a homogeneous mixture in which all particles of aggregate are coated uniformly. The total time required adding the bituminous material and completing the wet mixing shall be greater than 30 seconds.

The ingredients shall be heated and combined in such a manner as to produce a mixture which when discharged from the mixer should not, in general, vary more than 10 °C (20 °F) from the temperature set by the Engineer. In all cases, the temperature shall not exceed that shown in the table below.

Emulsified Bituminous Mixture	Liquid Bituminous Mixture	Asphalt Cement Mixture
120 °C (250 °F)	110 °C (225 °F)	180 °C (350 °F)

The ingredients of the seal coat mixture shall be combined in such proportions as to produce a mixture conforming to the following table:

MIXTURE COMPOSITION			
Sieve	% Passing <sup>1</sup>		% Residual Bitumen <sup>2</sup>
12.5 mm (1/2")		100	
9.5 mm (3/8")	98 -	100	
4.75 mm (No. 4)	75 -	90	
1.18 mm (No. 16)	35 -	70	
300 µm (No. 50)	5 -	20	
150 µm (No. 100)	2 -	6	
Residual Bitumen			4.5 - 7.5

- 1 - Based on percent of total aggregate weight.
- 2 - Based on percent of total mixture weight.

The percentage of residual bitumen will be set by the Engineer. The right is reserved by the Engineer to make such changes in proportions during the progress of the work as deemed necessary. The asphalt content shall not vary ± 0.5% from the bitumen content set by the Engineer.

Transportation of Mixture. This work shall be done in accordance with Article 1030.08.

Bituminous mixture which may not be spread and compacted during daylight shall not be sent to the work unless artificial light satisfactory to the Engineer is provided. The bituminous mixture shall not be hauled when the weather or road conditions are such that the hauling operations cause cutting up or rutting of the base, or the tracking of mud on the primed base or partially completed work.

Placing of Bituminous Mixture. The seal coat mixture shall be delivered at a temperature established by the Engineer commensurate with the mix temperature. The bituminous mixture shall be placed true to crown and grade with a spreading and finishing machine. The bituminous mixture may be spread and finished by approved hand methods only where machine methods are impractical, as in the case of special areas which because of irregularity, inaccessibility, or unavoidable obstacles do not lend themselves to mechanical placing. When the bituminous

mixture is placed in partial widths, the individual widths of the seal coat shall conform to the traffic lanes.

Placing of the bituminous mixture shall be as continuous as possible, and shall always be away from a transverse joint. The base or existing surface shall be kept clean, and any foreign material shall be removed to the satisfaction of the Engineer before the seal coat is placed.

The spreading and finishing machine shall spread the bituminous mixture without tearing the surface and shall strike a finish that is smooth, true to cross section, uniform in density and texture, free from hollows, transverse corrugations, and other irregularities. When the machine causes surface irregularities such as hollows or transverse corrugations, the machine shall be repaired or adjusted not later than the end of the day's work and it shall be in good working condition before work is resumed.

The machine shall be operated at a speed that will insure, as nearly as possible, continuous operation. The operating speed shall meet the approval of the Engineer. If, in the opinion of the engineer, the production of the plant exceeds the amount that can be laid satisfactorily with one finishing machine, the production shall be decreased or two machines shall be used.

The outside edges of the seal coat shall be sloped and pressed in place by means of a self-adjusting, constant pressure edge plate held in proper position on the finishing machine, except where the edges are supported by a curb, gutter or similar structure. A string line shall be used as a guide for the finishing machine in order to maintain a uniform edge alignment. If any other method is proposed, it shall meet the approval of the Engineer before being used. The edges of the finished seal coat shall be approximately vertical and no material shall extend beyond the limits of the base or existing surface.

Irregularities in alignment along the outside edges and along the longitudinal joint shall be corrected by adding or removing bituminous mixture before the edges are rolled. Excess bituminous mixtures deposited outside the limits of the lane being laid shall be removed immediately and disposed of as directed by the Engineer.

Compaction of Mixtures. Immediately after the seal coat mixture is placed it shall be compacted thoroughly and uniformly with a three-wheel roller or a tandem roller. Where initial rolling causes undue displacement, haircracking, or checking in the seal coat, the time of rolling shall be adjusted by the Engineer to correct these conditions.

One three-wheel roller and one tandem roller will be required on each project where the hourly production of the plant is 68 metric tons (75 tons) or less. One three-wheel roller and two tandem rollers will be required on each project where the hourly production of the plant is more than 68 metric tons (75 tons).

Rollers shall be operated by competent and experienced roller operators and shall be kept in operation as continuously as possible so that all parts of the pavement will receive substantially equal compaction at the time desired. During each 8 hour day of laying bituminous mixtures, each roller shall be engaged in actual rolling for more than 6.5 hours, and less than 1.5 hours shall be allowed for refueling, watering, and similar work. Delays in rolling freshly placed bituminous mixtures will not be permitted.

Rolling of the first lane of seal coat to be placed shall start longitudinally at the edge having the lower elevation and progress to the other edge, overlapping uniformly on successive trips by at least one-half the width of the rear wheels. Where laying the bituminous mixture adjacent to a previously placed lane, the first pass of the roller shall be along the longitudinal joint in such a manner that not more than one-third the width of the rear wheel is on the freshly placed mixture; after which the rolling shall proceed from the outside edge toward the longitudinal joint, overlapping uniformly on successive trips by at least one-half the width of the rear wheels. Succeeding trips of

the roller shall be terminated at least 1 m (3 feet) from the preceding stop. Each stop shall be regulated to prevent trapping of water on the rolled surface.

The roller shall not pass over an unprotected edge of the freshly laid bituminous mixture except when lying of the course is to be discontinued for any extended length of time.

The speed of the roller at all times shall be slow enough to avoid displacement of the bituminous mixture. If displacement occurs, it shall be corrected at once by raking and applying fresh bituminous mixture where required. To prevent adhesion of the bituminous mixture to the roller, the wheels shall be kept properly moistened but an excess of water will not be permitted.

Immediately after the initial rolling of the seal coat, the Contractor shall test the surface for smoothness with a 5 m (16 foot) straight-edge to locate high and low spots so that they may be corrected while the mixture is still workable. Rolling of the seal coat shall be continued until all roller marks are eliminated and the bituminous mixture is satisfactorily compacted.

When required by the Engineer, the seal coat shall be rolled diagonally in two directions with a tandem roller, the second rolling crossing the lines of the first, and if the width of the pavement permits, it shall also be rolled at right angles to the center line.

In all places inaccessible to the rollers, such as locations adjacent to curbs, gutters, headers, manholes, and similar structures, the required compaction shall be secured with hot tampers.

Any bituminous mixture that becomes loose, broken, mixed with foreign material, or which is defective in finish or density, or which does not comply in all other respects with the requirements of the specifications, shall be removed, replaced with suitable material, and finished in accordance with these specifications.

Protection of Pavement. The Contractor shall protect all sections of newly constructed seal coat from traffic until they have hardened to the satisfaction of the Engineer.

Method of Measurement. Bituminous priming material will be measured for payment as specified in Section 1032.

The seal coat mixture will be measured by weight in metric tons (tons). The mixture may be measured either by weighing the mixture on platform scales approved by the Engineer or on the basis of plant weights. If measured on the basis of plant weights, an occasional check will be made by weighing full truckloads of the bituminous mixture on an approved platform scale at the plant or an approved commercial scale. When the method of measurement is by truck weight, the weight of each load will be determined by weighing the truck each time before and after loading. If, during the course of construction, it becomes apparent that the weighman on the mixer platform or the weighman at the platform scale is not exercising proper care in weighing the bituminous mixture, he will be removed at the direction of the Engineer and replaced by a competent and qualified worker. Quantities of materials wasted or disposed of in a manner not called for in the contract will be deducted from the final total measured quantities. The contractor shall furnish approved duplicate load tickets upon which is recorded the net weight of the bituminous mixture in each truck. The tickets shall have sufficient space for signatures, identification of the bituminous mixture, date of delivery, and any other data that the Engineer may require. The Contractor shall submit one load ticket to the Engineer at the plant after the truck is loaded and the other load ticket to the Engineer at the work when the truck arrives.

Payment will not be made for seal coat mixture in excess of 105 % of the amount specified by the Engineer.

Basis of Payment. Prime Coat will be paid for at the contract unit price per metric ton (ton) or per liter (gallon) for BITUMINOUS MATERIALS (PRIME COAT)

The seal coat mixture will be paid for at the contract unit price per metric ton (ton) for BITUMINOUS HOT MIX SAND SEAL COAT.

State of Illinois  
DEPARTMENT OF TRANSPORTATION  
Bureau of Local Roads & Streets  
SPECIAL PROVISION  
FOR  
LOCAL QUALITY ASSURANCE/ QUALITY MANAGEMENT QC/QA  
Effective: January 1, 2022

Replace the first five paragraphs of Article 1030.06 of the Standard Specifications with the following:

**“1030.06 Quality Management Program.** The Quality Management Program (QMP) will be Quality Control / Quality Assurance (QC/QA) according to the following.”

Delete Article 1030.06(d)(1) of the Standard Specifications.

Revise Article 1030.09(g)(3) of the Standard Specifications to read:

“(3) If core testing is the density verification method, the Contractor shall provide personnel and equipment to collect density verification cores for the Engineer. Core locations will be determined by the Engineer following the document “Hot-Mix Asphalt QC/QA Procedure for Determining Random Density Locations” at density verification intervals defined in Article 1030.09(b). After the Engineer identifies a density verification location and prior to opening to traffic, the Contractor shall cut a 4 in. (100 mm) diameter core. With the approval of the Engineer, the cores may be cut at a later time.”

Revise Article 1030.09(h)(2) of the Standard Specifications to read:

“(2) After final rolling and prior to paving subsequent lifts, the Engineer will identify the random density verification test locations. Cores or nuclear density gauge testing will be used for density verification. The method used for density verification will be as selected below.

Density Verification Method	
<input type="checkbox"/>	Cores
<input checked="" type="checkbox"/>	Nuclear Density Gauge (Correlated when paving $\geq$ 3,000 tons per mixture)

Density verification test locations will be determined according to the document “Hot-Mix Asphalt QC/QA Procedure for Determining Random Density Locations”. The density testing interval for paving wider than or equal to 3 ft (1 m) will be 0.5 miles (800 m) for lift thicknesses of 3 in. (75 mm) or less and 0.2 miles (320 m) for lift thicknesses greater than 3 in. (75 mm). The density testing interval for paving less than 3 ft (1 m) wide will be 1 mile (1,600 m). If a day’s paving will be less than the prescribed density testing interval, the length of the day’s paving will be the interval for that day. The density testing interval for mixtures used for patching will be 50 patches with a minimum of one test per mixture per project.

If core testing is the density verification method, the Engineer will witness the Contractor coring, and secure and take possession of all density samples at the

density verification locations. The Engineer will test the cores collected by the Contractor for density according to Illinois Modified AASHTO T 166 or AASHTO T 275.

If nuclear density gauge testing is the density verification method, the Engineer will conduct nuclear density gauge tests. The Engineer will follow the density testing procedure detailed in the document "Illinois Modified ASTM D 2950, Standard Test Method for Density of Bituminous Concrete In-Place by Nuclear Method".

A density verification test will be the result of a single core or the average of the nuclear density tests at one location. The results of each density test must be within acceptable limits. The Engineer will promptly notify the Contractor of observed deficiencies."

Revise the seventh paragraph and all subsequent paragraphs in Section D. of the document "Hot-Mix Asphalt QC/QA Initial Daily Plant and Random Samples" to read:

"Mixtures shall be sampled from the truck at the plant by the Contractor following the same procedure used to collect QC mixture samples (Section A). This process will be witnessed by the Engineer who will take custody of the verification sample. Each sample bag with a verification mixture sample will be secured by the Engineer using a locking ID tag. Sample boxes containing the verification mixture sample will be sealed/taped by the Engineer using a security ID label."

State of Illinois  
DEPARTMENT OF TRANSPORTATION  
Bureau of Local Roads & Streets

SPECIAL PROVISION  
FOR  
EMULSIFIED ASPHALTS

Effective: January 1, 2007  
Revised: February 7, 2008

All references to Sections and Articles in this Special Provision shall be construed to mean specific Sections and Articles in the Standard Specifications for Road and Bridge Construction adopted by the Department of Transportation.

Replace the table after Note 2 in Article 403.02 with the following:

Type of Construction	Bituminous Materials Recommended for Weather Conditions Indicated	
	Warm [15 °C to 30 °C]* [(60 °F to 85 °F)]*	Hot [30 °C Plus]* [(85 °F Plus)]*
Prime	MC-30, PEP	MC-30, PEP
Cover Coat and Seal Coat	RS-2, CRS-2, RC-800, RC-3000, MC-800, MC-3000, SC-3000, HFE-90, HFE-150, HFE-300, HFRS-2, PEA**	RS-2, CRS-2, RC-800, RC-3000, MC-800, MC-3000, SC-3000, PG46-28, PG52-28, HFE-90, HFE-150, HFE-300, HFRS-2, PEA**

\* Temperature of the air in the shade at the time of application.

\*\* PEA is only allowed on roads with low traffic volumes

Replace the table after Note 2 in Article 406.02 with the following:

Type of Construction	Bituminous Materials Recommended
Prime (tack) on Brick, Concrete, or Bituminous Bases (Note 3)	SS-1, SS-1h, CSS-1, CSS-1h, HFE-90, RC-70
Prime on Aggregate Bases (Note 4)	MC-30, PEP
Mixture for Cracks, Joints, and Flangeways	PG58-22, PG64-22

Note 3. When emulsified asphalts are used, they shall be diluted with an equal volume of potable water. HFE emulsions shall be diluted by the manufacturer. The diluted material shall be thoroughly agitated within 24 hours of application and show no separation of water and emulsion. The diluted material shall not be returned to an approved emulsion storage tank.

Note 4. Preparation of the bituminous PEP shall be as specified in Article 403.05.

Replace the table in Article 1032.04 with the following:

Spraying Application Temperature Ranges		
Type and Grade of Bituminous Material	Temperature Ranges	
	°F min. - max.	°C min. - max.
PEP	60 - 130	15 - 55
PEA	140 - 190	60 - 88
MC-30	85 - 190	30 - 90
MC-70, RC-70, SC-70	120 - 225	50 - 105
MC-250, SC-250	165 - 270	75 - 130
MC-800, SC-800	200 - 305	95 - 150
MC-3000, SC-3000	230 - 345	110 - 175
PG46-28	275 - 385	135 - 195
PG52-28	285 - 395	140 - 200
RS-2, CRS-2	110 - 160	45 - 70
SS-1, SS-1h, CSS-1, CSS-1h	75 - 130	25 - 55
SS-1hP, CSS-1hP	75 - 130	25 - 55
HFE-90, HFE-150, HFE-300	150 - 180	65 - 80
HFP, CRSP, HFRS-2	150 - 180	65 - 80
E-2	85 - 190	30 - 90
E-3	120 - 225	50 - 105
E-4	165 - 270	75 - 130

Add subparagraph (g) to Article 1032.06:

- (g) Penetrating Emulsified Asphalt (PEA). The penetrating emulsified asphalt shall meet the following requirements when tested according to AASHTO T59:

Viscosity, Saybolt Fural @ 25°C (77°F),	sec:	20 - 500
Sieve Test, retained on 850 μm (No. 20) sieve, maximum,	%:	0.10
Storage Stability Test, 1 day, maximum,	%:	1
Float Test @ 60°C (140°F), minimum,	sec:	150
Stone Coating Test, 3 minutes,	:	Stone Coated Thoroughly
Particle Charge	:	Negative
pH, minimum	:	7.3
Distillation Test:		
Distillation to 260°C (500°F) Residue, minimum	%:	65
Oil Distillate by Volume, maximum	%:	3
Test on residue from distillation:		
Penetration @ 25°C (77°F), 100 g, 5 sec, minimum	dmm:	300

Replace the last sentence and table of Article 1032.06 with the following:

The different grades are, in general, used for the following.

Grade	Use
SS-1, SS-1h, CSS-1, CSS-1h, HFE 90, SS-1hP, CSS-1hP	Tack or fog seal
PEP	Bituminous surface treatment prime
RS-2, HFE 90, HFE 150, HFE 300, CRSP, HFP, CRS-2, HFRS-2, PEA	Bituminous surface treatment
CSS-1h Latex Modified	Microsurfacing



## Check Sheet for Recurring Special Provisions

Local Public Agency	County	Section Number
City of Princeton	Bureau	GEN FUNDS

**Check this box for lettings prior to 01/01/2026**

The Following Recurring Special Provisions Indicated By An "X" Are Applicable To This Contract And Are Included By Reference:

Recurring Special Provisions

<u>Check Sheet #</u>		<u>Page No.</u>
1	<input type="checkbox"/> Additional State Requirements for Federal-Aid Construction Contracts	87
2	<input type="checkbox"/> Subletting of Contracts (Federal-Aid Contracts)	90
3	<input type="checkbox"/> EEO	91
4	<input type="checkbox"/> Specific EEO Responsibilities Non Federal-Aid Contracts	101
5	<input type="checkbox"/> Required Provisions - State Contracts	106
6	<input type="checkbox"/> Asbestos Bearing Pad Removal	112
7	<input type="checkbox"/> Asbestos Waterproofing Membrane and Asbestos HMA Surface Removal	113
8	<input type="checkbox"/> Temporary Stream Crossings and In-Stream Work Pads	114
9	<input type="checkbox"/> Construction Layout Stakes	115
10	<input type="checkbox"/> Use of Geotextile Fabric for Railroad Crossing	118
11	<input type="checkbox"/> Subsealing of Concrete Pavements	120
12	<input type="checkbox"/> Hot-Mix Asphalt Surface Correction	124
13	<input type="checkbox"/> Pavement and Shoulder Resurfacing	126
14	<input type="checkbox"/> Patching with Hot-Mix Asphalt Overlay Removal	127
15	<input type="checkbox"/> Polymer Concrete	129
16	<input type="checkbox"/> Reserved	131
17	<input type="checkbox"/> Bicycle Racks	132
18	<input type="checkbox"/> Temporary Portable Bridge Traffic Signals	134
19	<input type="checkbox"/> Nighttime Inspection of Roadway Lighting	136
20	<input type="checkbox"/> English Substitution of Metric Bolts	137
21	<input type="checkbox"/> Calcium Chloride Accelerator for Portland Cement Concrete	138
22	<input type="checkbox"/> Quality Control of Concrete Mixtures at the Plant	139
23	<input type="checkbox"/> Quality Control/Quality Assurance of Concrete Mixtures	147
24	<input type="checkbox"/> Reserved	163
25	<input type="checkbox"/> Reserved	164
26	<input type="checkbox"/> Temporary Raised Pavement Markers	165
27	<input type="checkbox"/> Restoring Bridge Approach Pavements Using High-Density Foam	166
28	<input type="checkbox"/> Portland Cement Concrete Inlay or Overlay	169
29	<input type="checkbox"/> Portland Cement Concrete Partial Depth Hot-Mix Asphalt Patching	173
30	<input type="checkbox"/> Longitudinal Joint and Crack Patching	176
31	<input type="checkbox"/> Concrete Mix Design - Department Provided	178
32	<input type="checkbox"/> Station Numbers in Pavements or Overlays	179

City of Princeton

Bureau

GEN FUNDS

The Following Local Roads And Streets Recurring Special Provisions Indicated By An "X" Are Applicable To This Contract And Are Included By Reference:

Local Roads And Streets Recurring Special Provisions

<u>Check Sheet #</u>		<u>Page No.</u>
LRS 1	<b>Reserved</b>	181
LRS 2	<input type="checkbox"/> Furnished Excavation	182
LRS 3	<input checked="" type="checkbox"/> Work Zone Traffic Control Surveillance	183
LRS 4	<input checked="" type="checkbox"/> Flaggers in Work Zones	184
LRS 5	<input checked="" type="checkbox"/> Contract Claims	185
LRS 6	<input checked="" type="checkbox"/> Bidding Requirements and Conditions for Contract Proposals	186
LRS 7	<input type="checkbox"/> Bidding Requirements and Conditions for Material Proposals	192
LRS 8	<b>Reserved</b>	198
LRS 9	<input type="checkbox"/> Bituminous Surface Treatments	199
LRS 10	<b>Reserved</b>	203
LRS 11	<input checked="" type="checkbox"/> Employment Practices	204
LRS 12	<input checked="" type="checkbox"/> Wages of Employees on Public Works	206
LRS 13	<input checked="" type="checkbox"/> Selection of Labor	208
LRS 14	<input type="checkbox"/> Paving Brick and Concrete Paver Pavements and Sidewalks	209
LRS 15	<input checked="" type="checkbox"/> Partial Payments	212
LRS 16	<input checked="" type="checkbox"/> Protests on Local Lettings	213
LRS 17	<input checked="" type="checkbox"/> Substance Abuse Prevention Program	214
LRS 18	<input type="checkbox"/> Multigrade Cold Mix Asphalt	215
LRS 19	<input type="checkbox"/> Reflective Crack Control Treatment	216

BDE SPECIAL PROVISIONS  
For the April 24 and June 12, 2026 Lettings

The following special provisions indicated by a “check mark” are applicable to this contract and will be included by the Project Coordination and Implementation Section of the Bureau of Design & Environment (BDE).

File Name	#		Special Provision Title	Effective	Revised	
	80099	1	<input type="checkbox"/>	Accessible Pedestrian Signals (APS)	April 1, 2003	Jan. 1, 2022
	80274	2	<input type="checkbox"/>	Aggregate Subgrade Improvement	April 1, 2012	April 1, 2022
	80192	3	<input type="checkbox"/>	Automated Flagger Assistance Devices	Jan. 1, 2008	April 1, 2023
	80173	4	<input type="checkbox"/>	Bituminous Materials Cost Adjustments	Nov. 2, 2006	Aug. 1, 2017
	80426	5	<input checked="" type="checkbox"/>	Bituminous Surface Treatment with Fog Seal	Jan. 1, 2020	April 1, 2026
	80475	6	<input type="checkbox"/>	Bridge Deck Concrete Overlays	Jan. 1, 2026	
*	80241	7	<input type="checkbox"/>	Bridge Demolition Debris	July 1, 2009	
*	50531	8	<input type="checkbox"/>	Building Removal	Sept. 1, 1990	Aug. 1, 2022
*	50261	9	<input type="checkbox"/>	Building Removal with Asbestos Abatement	Sept. 1, 1990	Aug. 1, 2022
	80460	10	<input type="checkbox"/>	Cement, Finely Divided Minerals, Admixtures, Concrete, and Mortar	Jan. 1, 2025	Jan. 1, 2026
	80384	11	<input checked="" type="checkbox"/>	Compensable Delay Costs	June 2, 2017	April 1, 2019
*	80198	12	<input type="checkbox"/>	Completion Date (via calendar days)	April 1, 2008	
*	80199	13	<input type="checkbox"/>	Completion Date (via calendar days) Plus Working Days	April 1, 2008	
	80461	14	<input type="checkbox"/>	Concrete Barrier	Jan. 1, 2025	
	80453	15	<input type="checkbox"/>	Concrete Sealer	Nov. 1, 2023	
	80261	16	<input type="checkbox"/>	Construction Air Quality – Diesel Retrofit	June 1, 2010	Jan. 1, 2025
	80476	17	<input type="checkbox"/>	Deck Slab Repair	Jan. 1, 2026	
*	80029	18	<input type="checkbox"/>	Disadvantaged Business Enterprise Participation	Sept. 1, 2000	Jan. 2, 2025
	80467	19	<input type="checkbox"/>	Erosion Control Blanket	Aug. 1, 2025	
	80229	20	<input type="checkbox"/>	Fuel Cost Adjustment	April 1, 2009	Aug. 1, 2017
	80452	21	<input type="checkbox"/>	Full Lane Sealant Waterproofing System	Nov. 1, 2023	
	80433	22	<input type="checkbox"/>	Green Preformed Thermoplastic Pavement Markings	Jan. 1, 2021	Jan. 1, 2022
	80471	23	<input type="checkbox"/>	Guardrail	Nov. 1, 2025	
	80472	24	<input type="checkbox"/>	High Friction Surface Treatment	Nov. 1, 2025	
	80456	25	<input checked="" type="checkbox"/>	Hot-Mix Asphalt	Jan. 1, 2024	April 1, 2026
	80446	26	<input type="checkbox"/>	Hot-Mix Asphalt - Longitudinal Joint Sealant	Nov. 1, 2022	Aug. 1, 2023
	80438	27	<input type="checkbox"/>	Illinois Works Apprenticeship Initiative – State Funded Contracts	June 2, 2021	April 2, 2024
	80483	28	<input type="checkbox"/>	Inlet Filters	April 1, 2026	
	80477	29	<input type="checkbox"/>	Longitudinal Tining	Jan. 1, 2026	
	80450	30	<input type="checkbox"/>	Mechanically Stabilized Earth Retaining Walls	Aug. 1, 2023	Aug. 1, 2025
	80478	31	<input type="checkbox"/>	Modified Longitudinal Construction Joint	Jan. 1, 2026	
	80464	32	<input type="checkbox"/>	Pavement Marking	April. 1, 2025	Nov. 1, 2025
	80468	33	<input type="checkbox"/>	Pavement Patching	Aug. 1, 2025	
	80441	34	<input type="checkbox"/>	Performance Graded Asphalt Binder	Jan. 1, 2023	April 1, 2026
	80459	35	<input type="checkbox"/>	Preformed Plastic Pavement Marking	June 2, 2024	
*	34261	36	<input type="checkbox"/>	Railroad Protective Liability Insurance	Dec. 1, 1986	Jan. 1, 2022
	80473	37	<input type="checkbox"/>	Raised Reflective Pavement Markers	Nov. 1, 2025	
	80455	38	<input type="checkbox"/>	Removal and Disposal of Regulated Substances	Jan. 1, 2024	April 1, 2026
	80474	39	<input type="checkbox"/>	Residential Driveway Temporary Signal	Nov. 1, 2025	
	80445	40	<input type="checkbox"/>	Seeding	Nov. 1, 2022	
	80457	41	<input type="checkbox"/>	Short Term and Temporary Pavement Markings	April 1, 2024	April 2, 2024
	80462	42	<input type="checkbox"/>	Sign Panels and Appurtenances	Jan. 1, 2025	Jan. 1, 2026
	80479	43	<input type="checkbox"/>	Sinusoidal Rumble Strips	Jan. 1, 2026	
	80469	44	<input type="checkbox"/>	Slope Wall	Aug. 1, 2025	
	80448	45	<input type="checkbox"/>	Source of Supply and Quality Requirements	Jan. 2, 2023	Jan. 1, 2026
	80340	46	<input type="checkbox"/>	Speed Display Trailer	April 2, 2014	Jan. 1, 2022
	80127	47	<input type="checkbox"/>	Steel Cost Adjustment	April 2, 2004	Nov. 1, 2025
	80480	48	<input type="checkbox"/>	Structural Repair of Concrete	Jan. 1, 2026	
	80397	49	<input type="checkbox"/>	Subcontractor and DBE Payment Reporting	April 2, 2018	
	80391	50	<input type="checkbox"/>	Subcontractor Mobilization Payments	Nov. 2, 2017	April 1, 2019
	80463	51	<input type="checkbox"/>	Submission of Bidders List Information	Jan. 2, 2025	Mar. 2, 2025

	80482	52	<input type="checkbox"/>	Submission of Payroll Records – Federal Aid Contract	April 1, 2026	
	80437	53	<input type="checkbox"/>	Submission of Payroll Records – State Contract	April 1, 2021	April 1, 2026
	80435	54	<input type="checkbox"/>	Surface Testing of Pavements – IRI	Jan. 1, 2021	Jan. 1, 2023
	80465	55	<input type="checkbox"/>	Surveying Services	April 1, 2025	
	80481	56	<input type="checkbox"/>	Temporary Concrete Barrier	Jan. 1, 2026	
	80466	57	<input type="checkbox"/>	Temporary Rumble Strips	April 1, 2025	
	80470	58	<input type="checkbox"/>	Traffic Signal Backplate	Aug. 1, 2025	
*	20338	59	<input type="checkbox"/>	Training Special Provisions	Oct. 15, 1975	Sept. 2, 2021
	80429	60	<input type="checkbox"/>	Ultra-Thin Bonded Wearing Course	April 1, 2020	Jan. 1, 2022
	80439	61	<input checked="" type="checkbox"/>	Vehicle and Equipment Warning Lights	Nov. 1, 2021	Nov. 1, 2022
	80458	62	<input type="checkbox"/>	Waterproofing Membrane System	Aug. 1, 2024	
	80302	63	<input type="checkbox"/>	Weekly DBE Trucking Reports	June 2, 2012	Jan. 2, 2025
	80454	64	<input type="checkbox"/>	Wood Sign Support	Nov. 1, 2023	
	80427	65	<input checked="" type="checkbox"/>	Work Zone Traffic Control Devices	Mar. 2, 2020	Jan. 1, 2026
*	80071	66	<input checked="" type="checkbox"/>	Working Days	Jan. 1, 2002	

Highlighted items indicate a new or revised special provision for the letting.

An \* indicates the special provision requires additional information from the designer, which needs to be submitted separately. The Project Coordination and Implementation Section will then include the information in the applicable special provision.

The following special provisions are in the 2026 Supplemental Specifications and Recurring Special Provisions.

<u>File Name</u>	<u>Special Provision Title</u>	<u>New Location(s)</u>	<u>Effective</u>	<u>Revised</u>
80447	Grading and Shaping Ditches	Articles 214.03 & 214.04	Jan. 1, 2023	

## **TRAINING SPECIAL PROVISIONS (BDE)**

Effective: October 15, 1975

Revised: September 2, 2021

This Training Special Provision supersedes Section 7b of the Special Provision entitled "Specific Equal Employment Opportunity Responsibilities," and is in implementation of 23 U.S.C. 140(a).

As part of the Contractor's equal employment opportunity affirmative action program, training shall be provided as follows:

The Contractor shall provide on-the-job training aimed at developing full journeyman in the type of trade or job classification involved. The number of trainees to be trained under this contract will be \_\_\_\_\_. In the event the Contractor subcontracts a portion of the contract work, it shall determine how many, if any, of the trainees are to be trained by the subcontractor, provided however, that the Contractor shall retain the primary responsibility for meeting the training requirements imposed by this special provision. The Contractor shall also ensure that this Training Special Provision is made applicable to such subcontract. Where feasible, 25 percent of apprentices or trainees in each occupation shall be in their first year of apprenticeship or training.

The number of trainees shall be distributed among the work classifications on the basis of the Contractor's needs and the availability of journeymen in the various classifications within the reasonable area of recruitment. Prior to commencing construction, the Contractor shall submit to the Illinois Department of Transportation for approval the number of trainees to be trained in each selected classification and training program to be used. Furthermore, the Contractor shall specify the starting time for training in each of the classifications. The Contractor will be credited for each trainee it employs on the contract work who is currently enrolled or becomes enrolled in an approved program and will be reimbursed for such trainees as provided hereinafter.

Training and upgrading of minorities and women toward journeyman status is a primary objective of this Training Special Provision. Accordingly, the Contractor shall make every effort to enroll minority trainees and women (e.g. by conducting systematic and direct recruitment through public and private sources likely to yield minority and women trainees) to the extent such persons are available within a reasonable area of recruitment. The Contractor will be responsible for demonstrating the steps it has taken in pursuance thereof, prior to a determination as to whether the Contractor is in compliance with this Training Special Provision. This training commitment is not intended, and shall not be used, to discriminate against any applicant for training, whether a member of a minority group or not.

No employee shall be employed as a trainee in any classification in which he or she has successfully completed a training course leading to journeyman status or in which he or she has been employed as a journeyman. The Contractor should satisfy this requirement by including appropriate questions in the employee application or by other suitable means. Regardless of the method used, the Contractor's records should document the findings in each case.

The minimum length and type of training for each classification will be as established in the training program selected by the Contractor and approved by the Illinois Department of Transportation and the Federal Highway Administration. The Illinois Department of Transportation and the Federal Highway Administration shall approve a program, if it is reasonably calculated to meet the equal employment opportunity obligations of the Contractor and to qualify the average trainee for journeyman status in the classification concerned by the end of the training period. Furthermore, apprenticeship programs registered with the U.S. Department of Labor, Bureau of Apprenticeship and Training, or with a State apprenticeship agency recognized by the Bureau and training programs approved by not necessarily sponsored by the U.S. Department of Labor Employment Training Administration shall also be considered acceptable provided it is being administered in a manner consistent with the equal employment obligations of Federal-aid highway construction contracts. Approval or acceptance of a training program shall be obtained from the State prior to commencing work on the classification covered by the program. It is the intention of these provisions that training is to be provided in the construction crafts rather than clerk-typists or secretarial-type positions. Training is permissible in lower level management positions such as office engineers, estimators, timekeepers, etc., where the training is oriented toward construction applications. Training in the laborer classification may be permitted provided that significant and meaningful training is provided and approved by the Illinois Department of Transportation and the Federal Highway Administration. Some offsite training is permissible as long as the training is an integral part of an approved training program and does not comprise a significant part of the overall training.

Except as otherwise noted below, the Contractor will be reimbursed 80 cents per hour of training given an employee on this contract in accordance with an approved training program. As approved by the Engineer, reimbursement will be made for training of persons in excess of the number specified herein. This reimbursement will be made even though the Contractor receives additional training program funds from other sources, provided such other source does not specifically prohibit the Contractor from receiving other reimbursement. Reimbursement for offsite training indicated above may only be made to the Contractor where he does one or more of the following and the trainees are concurrently employed on a Federal-aid project; contributes to the cost of the training, provides the instruction to the trainee or pays the trainee's wages during the offsite training period.

No payment shall be made to the Contractor if either the failure to provide the required training, or the failure to hire the trainee as a journeyman, is caused by the Contractor and evidences a lack of good faith on the part of the Contractor in meeting the requirement of this Training Special Provision. It is normally expected that a trainee will begin his training on the project as soon as feasible after start of work utilizing the skill involved and remain on the project as long as training opportunities exist in his work classification or until he has completed his training program.

It is not required that all trainees be on board for the entire length of the contract. A Contractor will have fulfilled his responsibilities under this Training Special Provision if he has provided acceptable training to the number of trainees specified. The number trained shall be determined on the basis of the total number enrolled on the contract for a significant period.

Trainees will be paid at least 60 percent of the appropriate minimum journeyman's rate specified in the contract for the first half of the training period, 75 percent for the third quarter of the training period, and 90 percent for the last quarter of the training period, unless apprentices or trainees in an approved existing program are enrolled as trainees on this project. In that case, the appropriate rates approved by the Departments of Labor or Transportation in connection with the existing program shall apply to all trainees being trained for the same classification who are covered by this Training Special Provision.

The Contractor shall furnish the trainee a copy of the program he will follow in providing the training. The Contractor shall provide each trainee with a certification showing the type and length of training satisfactorily complete.

The Contractor shall provide for the maintenance of records and furnish periodic reports documenting its performance under this Training Special Provision.

For contracts with an awarded contract value of \$500,000 or more, the Contractor is required to comply with the Illinois Works Apprenticeship Initiative (30 ILCS 559/20-20 to 20-25) and all applicable administrative rules to the extent permitted by Section 20-20(g). For federally funded projects, the number of trainees to be trained under this contract, as stated in the Training Special Provisions, will be the established goal for the Illinois Works Apprenticeship Initiative 30 ILCS 559/20-20(g). The Contractor shall make a good faith effort to meet this goal. For federally funded projects, the Illinois Works Apprenticeship Initiative will be implemented using the FHWA approved OJT procedures. The Contractor must comply with the recordkeeping and reporting obligations of the Illinois Works Apprenticeship Initiative for the life of the project, including the certification as to whether the trainee/apprentice labor hour goals were met.

Method of Measurement. The unit of measurement is in hours.

Basis of Payment. This work will be paid for at the contract unit price of 80 cents per hour for TRAINEES. The estimated total number of hours, unit price, and total price have been included in the schedule of prices.

20338

The districts should include the BDE Check Sheet marked with the applicable special provisions for the January 21, 2022 and subsequent lettings. The Project Coordination and Implementation Section will include a copy in the contract.

3426lm

**RAILROAD PROTECTIVE LIABILITY INSURANCE (BDE)**

Effective: December 1, 1986  
Revised: January 1, 2022

Description. Railroad Protective Liability and Property Damage Liability Insurance shall be carried according to Article 107.11 of the Standard Specifications. A separate policy is required for each railroad unless otherwise noted.

---

NAMED INSURED & ADDRESS	NUMBER & SPEED OF PASSENGER TRAINS	NUMBER & SPEED OF FREIGHT TRAINS
-------------------------	------------------------------------	----------------------------------

---

Class 1 RR (Y or N):  
DOT/AAR No.:  
RR Division:

RR Mile Post:  
RR Sub-Division:

For Freight/Passenger Information Contact:  
For Insurance Information Contact:

Phone:  
Phone:

---

Class 1 RR (Y or N):  
DOT/AAR No.:  
RR Division:

RR Mile Post:  
RR Sub-Division:

For Freight/Passenger Information Contact:  
For Insurance Information Contact:

Phone:  
Phone:

---

Basis of Payment. Providing Railroad Protective Liability and Property Damage Liability Insurance will be paid for at the contract unit price per Lump Sum for RAILROAD PROTECTIVE LIABILITY INSURANCE.

## **BUILDING REMOVAL WITH ASBESTOS ABATEMENT (BDE)**

Effective: September 1, 1990

Revised: August 1, 2022

Description. This work shall consist of the removal and disposal of building(s), including all foundations, retaining walls, and piers, down to a plane 1 ft (300 mm) below the ultimate bottom of building elevation or proposed bottom of construction elevation. The building(s) are identified as follows:

<u>Bldg. No.</u>	<u>Parcel No.</u>	<u>Location</u>	<u>Description</u>
------------------	-------------------	-----------------	--------------------

### **CONSTRUCTION REQUIREMENTS**

General. The IEPA's "State of Illinois Demolition/Renovation/Asbestos Project Notification Form" shall be submitted and a copy sent to the Engineer. It shall be updated if there is a change in the start and/or finish date or if the quantity of asbestos changes by more than 20 percent.

Asbestos abatement work shall be performed by an IDPH licensed Contractor prequalified with the Illinois Capital Development Board who has an on-site supervisor licensed by IDPH and employs workers licensed by IDPH. This work shall be completed according to the requirements of the U.S. Environmental Protection Agency (USEPA), IEPA, OSHA, and local regulatory agencies.

Discontinuance of Utilities. The Contractor shall arrange for the discontinuance of all utility services and the removal of the metering devices that serve the building(s) according to the respective requirements and regulations of the city, county, or utility companies involved. The Contractor shall disconnect and seal the service outlets.

Posting. Upon execution of the contract and prior to the removal of any buildings, the Contractor shall paint or stencil, in contrasting colors of an oil base paint, on all sides of each building or structure, the following posting:

NO TRESPASSING  
VIOLATORS WILL BE PROSECUTED

The postings shall be positioned prominently on the structure(s) so they can be easily read and at a sufficient height to prevent defacing.

Asbestos Abatement. Friable asbestos containing building materials (ACBMs) and Category II non-friable ACBMs shall be removed from the building(s) prior to demolition. Category II non-friable ACBMs include asbestos containing transite boards, siding, and other cementitious materials (cement pipe or highly weathered roofing shingles/materials) which have a likelihood of becoming friable during typical demolition activities (by crumbling, pulverizing, or otherwise reducing to powder) making them regulated asbestos containing materials (RACM). Removed ACBM shall be kept separate from non-ACBM demolition debris for purposes of transport and disposal.

Category I non-friable ACBM may be kept in place for demolition or removal of the building unless it has become friable as determined by the ACBM inspector. If the Contractor demolishes the building(s) with the non-friable asbestos in place, the following shall apply.

- (a) The Contractor shall continuously wet the non-friable ACBM and other building debris with water during demolition and loading for disposal.
- (b) The Contractor shall dispose of all demolition debris as ACBM.

The Contractor shall perform air monitoring during asbestos abatement activities. Air sampling shall be conducted by a qualified air sampling professional. Air sampling shall be conducted according to NIOSH Method 7400. Air monitoring equipment shall be calibrated and maintained in proper operating condition. The Contractor shall submit a copy of the air sampling professional's certificate to the Engineer. The results of the tests, and daily calibration and maintenance records shall be kept on site and be available to the Engineer upon request.

Personal monitoring shall be conducted per applicable OSHA regulations. Excursion limits shall be monitored daily, and corrective actions taken immediately to bring excursions within OSHA permissible exposure limits.

When asbestos is removed prior to demolition, clearance testing per IDPH shall be conducted upon the removal of ACBM.

Submittals. The following submittals shall be made to the Engineer prior to the start of the asbestos abatement:

- (a) Manufacturer's certification stating that vacuums, ventilation equipment, and other equipment required to contain airborne fibers conform to ANSI 29.2.
- (b) A listing of the brand name, manufacturer, and specification of all sealants or surfactants to be used.
- (c) Proof that arrangements for transport and disposal of ACBMs have been obtained (i.e., a letter of authorization to utilize designated landfill).
- (d) A detailed work plan of the Contractor's anticipated procedures including the location and layout of decontamination units, the sequencing of work, the respiratory protection plan, a

site safety plan, a disposal plan, and a detailed description of the methods to be used to control pollution.

- (e) Proof of the Contractor's prequalification with Capital Development Board and employee certifications with IDPH.

Submittals that shall be made upon completion of abatement work:

- (f) Copies of waste chain-of-custodies, trip tickets, shipping manifests, or disposal receipts for asbestos waste materials removed from the work area.
- (g) Copies of each day's work site entry logbook with information on worker and visitor access.
- (h) Logs documenting filter changes on respirators, HEPA vacuums, negative pressure ventilation units, and other engineering controls.
- (i) Test results of any bulk material analysis and air sampling data collected during the abatement including results of any on-site testing by any federal, state, or local agency.

Any holes, such as basements, shall be backfilled according to Article 502.10.

Basis of Payment. This work will be paid for at the contract lump sum unit price for BUILDING REMOVAL NO. \_\_\_\_.

Removal and disposal of friable ACBM will be paid for at the contract lump sum unit price for REMOVAL AND DISPOSAL OF FRIABLE ASBESTOS, BUILDING NO. \_\_\_\_.

Removal and disposal of non-friable ACBM will be paid for at the contract lump sum unit price for REMOVAL AND DISPOSAL OF NON-FRIABLE ASBESTOS, BUILDING NO. \_\_\_\_.

**BUILDING REMOVAL (BDE)**

Effective: September 1, 1990

Revised: August 1, 2022

Description. This work shall consist of the removal and disposal of building(s), including all foundations, retaining walls, and piers, down to a plane 1 ft (300 mm) below the ultimate bottom of building elevation or proposed bottom of construction elevation. The building(s) are identified as follows:

<u>Bldg. No.</u>	<u>Parcel No.</u>	<u>Location</u>	<u>Description</u>
------------------	-------------------	-----------------	--------------------

**CONSTRUCTION REQUIREMENTS**

General. The IEPA's "State of Illinois Demolition/Renovation/Asbestos Project Notification Form" shall be submitted and a copy sent to the Engineer. It shall be updated if there is a change in the start and/or finish date or if asbestos is found to be present in the building(s) to be removed.

Discontinuance of Utilities. The Contractor shall arrange for the discontinuance of all utility services and the removal of the metering devices that serve the building(s) according to the respective requirements and regulations of the city, county, and utility companies involved. The Contractor shall disconnect and seal the service outlets.

Posting. Upon execution of the contract and prior to the removal of any buildings, the Contractor shall paint or stencil, in contrasting colors of an oil base paint, on all sides of each building or structure, the following posting:

NO TRESPASSING  
VIOLATORS WILL BE PROSECUTED

The postings shall be positioned prominently on the structure so they can be easily read and at a sufficient height to prevent defacing.

Any holes, such as basements, shall be backfilled according to Article 502.10.

Basis of Payment. This work will be paid for at the contract lump sum unit price for BUILDING REMOVAL NO. \_\_\_\_.

## **DISADVANTAGED BUSINESS ENTERPRISE PARTICIPATION (BDE)**

Effective: September 1, 2000

Revised: January 2, 2025

1. OVERVIEW AND GENERAL OBLIGATION. The Department of Transportation, as a recipient of federal financial assistance, is required to take all necessary and reasonable steps to ensure nondiscrimination in the award and administration of contracts. Consequently, the federal regulatory provisions of 49 CFR Part 26 apply to this contract concerning the utilization of disadvantaged business enterprises. For the purposes of this Special Provision, a disadvantaged business enterprise (DBE) means a business certified in accordance with the requirements of 49 CFR Part 26 and listed in the Illinois Unified Certification Program (IL UCP) DBE Directory. Award of the contract is conditioned on meeting the requirements of 49 CFR Part 26, and failure by the Contractor to carry out the requirements of Part 26 is a material breach of the contract and may result in the termination of the contract or such other remedies as the Department deems appropriate.
2. CONTRACTOR ASSURANCE. All assurances set forth in FHWA 1273 are hereby incorporated by reference and will be physically attached to the final contract and all subcontracts.
3. CONTRACT GOAL TO BE ACHIEVED BY THE CONTRACTOR. The Department has determined the work of this contract has subcontracting opportunities that may be suitable for performance by DBE companies and that, in the absence of unlawful discrimination and in an arena of fair and open competition, DBE companies can be expected to perform \_\_\_\_\_% of the work. This percentage is set as the DBE participation goal for this contract. Consequently, in addition to the other award criteria established for this contract, the Department will only award this contract to a bidder who makes a good faith effort to meet this goal of DBE participation in the performance of the work in accordance with the requirements of 49 CFR 26.53 and SBE Memorandum No. 24-02.
4. IDENTIFICATION OF CERTIFIED DBE. Information about certified DBE Contractors can be found in the Illinois UCP Directory. Bidders can obtain additional information and assistance with identifying DBE-certified companies at the Department's website or by contacting the Department's Bureau of Small Business Enterprises at (217) 785-4611.
5. BIDDING PROCEDURES. Compliance with this Special Provision and SBE Policy Memorandum 24-02 is a material bidding requirement. The following shall be included with the bid.
  - (a) DBE Utilization Plan (form SBE 2026) documenting enough DBE participation has been obtained to meet the goal, or a good faith effort has been made to meet the goal even though the efforts did not succeed in obtaining enough DBE participation to meet the goal.

(b) Applicable DBE Participation Statement (form SBE 2023, 2024, and/or 2025) for each DBE firm the bidder has committed to perform the work to achieve the contract goal.

The required forms and documentation shall be submitted as a single .pdf file using the "Integrated Contractor Exchange (iCX)" application within the Department's "EBids System".

The Department will not accept a bid if it does not meet the bidding procedures set forth herein and the bid will be declared non-responsive. A bidder declared non-responsive for failure to meet the bidding procedures will not give rise to an administrative reconsideration. In the event the bid is declared non-responsive, the Department may elect to cause the forfeiture of the penal sum of the bidder's proposal guaranty and may deny authorization to bid the project if re-advertised for bids.

6. UTILIZATION PLAN EVALUATION. The contract will not be awarded until the Utilization Plan is approved. All information submitted by the bidder must be complete, accurate, and adequately document the bidder has committed to DBE participation sufficient to meet the goal, or that the bidder has made good faith efforts to do so, in the event the bidder cannot meet the goal, in order for the Department to commit to the performance of the contract by the bidder.

The Utilization Plan will be approved by the Department if the Utilization Plan documents sufficient commercially useful DBE work to meet the contract goal or the Department determines, based upon the documentation submitted, that the bidder has made a good faith effort to meet the contract goal pursuant to 49 CFR Part 26, Appendix A and the requirements of SBE 2026.

If the Department determines that a good faith effort has not been made, the Department will notify the responsible company official designated in the Utilization Plan of that determination in accordance with SBE Policy Memorandum 24-02.

7. CALCULATING DBE PARTICIPATION. The Utilization Plan values represent work the bidder commits to have performed by the specified DBEs and paid for upon satisfactory completion. The Department is only able to count toward the achievement of the overall goal and the contract goal the value of payments made for the work actually performed by DBE firms. In addition, a DBE must perform a commercially useful function on the contract to be counted. A commercially useful function is generally performed when the DBE is responsible for the work and is carrying out its responsibilities by actually performing, managing, and supervising the work involved. The Department and Contractor are governed by the provisions of 49 CFR Part 26.55(c) on questions of commercially useful functions as it affects the work. Specific guidelines for counting goal credit are provided in 49 CFR Part 26.55. In evaluating Utilization Plans for award the Department will count goal credit as set forth in Part 26 and in accordance with SBE Policy Memorandum 24-02.
8. CONTRACT COMPLIANCE. The Contractor must utilize the specific DBEs listed to perform the work and supply the materials for which each DBE is listed in the Contractor's approved Utilization Plan, unless the Contractor obtains the Department's written consent to

terminate the DBE or any portion of its work. The DBE Utilization Plan approved by SBE is a condition-of-award, and any deviation to that Utilization Plan, the work set forth therein to be performed by DBE firms, or the DBE firms specified to perform that work, must be approved, in writing, by the Department in accordance with federal regulatory requirements. Deviation from the DBE Utilization Plan condition-of-award without such written approval is a violation of the contract and may result in termination of the contract or such other remedy the Department deems appropriate. The following administrative procedures and remedies govern the compliance by the Contractor with the contractual obligations established by the Utilization Plan.

- (a) NOTICE OF DBE PERFORMANCE. The Contractor shall provide the Engineer with at least three days advance notice of when all DBE firms are expected to perform the work committed under the Contractor's Utilization Plan.
- (b) SUBCONTRACT. If awarded the contract, the Contractor is required to enter into written subcontracts with all DBE firms indicated in the approved Utilization Plan and must provide copies of fully executed DBE subcontracts to the Department upon request. Subcontractors shall ensure that all lower tier subcontracts or agreements with DBEs to supply labor or materials be performed in accordance with this Special Provision.
- (c) PAYMENT TO DBE FIRMS. The Department is prohibited by federal regulations from crediting the participation of a DBE included in the Utilization Plan toward either the contract goal or the Department's overall goal until the amount to be applied toward the goal has been paid to the DBE. The Contractor shall document and report all payments for work performed by DBE certified firms in accordance with Article 109.11 of the Standard Specifications. All records of payment for work performed by DBE certified firms shall be made available to the Department upon request.
- (d) FINAL PAYMENT. After the performance of the final item of work or trucking, or delivery of material by a DBE and final payment to the DBE by the Contractor, but not later than 30 calendar days after payment has been made by the Department to the Contractor for such work or material, the Contractor shall submit a DBE Payment Agreement (form SBE 2115) to the Engineer. If the Contractor does not have the full amount of work indicated in the Utilization Plan performed by the DBE companies indicated in the Utilization Plan and after good faith efforts are reviewed, the Department may deduct from contract payments to the Contractor the amount of the goal not achieved as liquidated and ascertained damages.
- (g) ENFORCEMENT. The Department reserves the right to withhold payment to the Contractor to enforce the provisions of this Special Provision. Final payment shall not be made on the contract until such time as the Contractor submits sufficient documentation demonstrating achievement of the goal in accordance with this Special Provision or after liquidated damages have been determined and collected.

All District Engineers, Walter S. Kos & Miguel d'Escoto

Michael L. Hine

Special Provision for Working Days

January 11, 2002

This special provision was developed by the Bureau of Design & Environment as a result of changes to the letting proposal.

It should be inserted into all working day contracts.

The districts should include the BDE Check Sheet marked with the applicable special provisions for the April 26, 2002 and subsequent lettings. The Project Development and Implementation Section will include the paper copy in the contract.

This special provision will be transferred through the E-mail System to the district offices on January 11, 2002.

80071m

**WORKING DAYS (BDE)**

Effective: January 1, 2002

The Contractor shall complete the work within            working days.

80071

## ACCESSIBLE PEDESTRIAN SIGNALS (APS) (BDE)

Effective: April 1, 2003

Revised: January 1, 2022

Description. This work shall consist of furnishing and installing accessible pedestrian signals (APS). Each APS shall consist of an interactive vibrotactile pedestrian pushbutton with speaker, an informational sign, a light emitting diode (LED) indicator light, a solid-state electronic control board, a power supply, wiring, and mounting hardware. The APS shall meet the requirements of the MUTCD and Sections 801 and 888 of the Standard Specifications, except as modified herein.

Electrical Requirements. The APS shall operate with systems providing 95 to 130 VAC, 60 Hz and throughout an ambient air temperature range of -29 to +160 °F (-34 to +70 °C).

The APS shall contain a power protection circuit consisting of both fuse and transient protection.

Audible Indications. A pushbutton locator tone shall sound at each pushbutton and shall be deactivated during the associated walk indication and when associated traffic signals are in flashing mode. Pushbutton locator tones shall have a duration of 0.15 seconds or less and shall repeat at 1-second intervals. Each actuation of the pushbutton shall be accompanied by the speech message "Wait".

If two accessible pedestrian pushbuttons are placed less than 10 ft (3 m) apart or placed on the same pole, the audible walk indication shall be a speech walk message. This message shall sound throughout the WALK interval only. The verbal message shall be modeled after: "Street Name, Walk Sign is on to cross "Street Name." For signalized intersections utilizing exclusive pedestrian phasing, the verbal message shall be "Walk sign is on for all crossings". In addition, a speech pushbutton information message shall be provided by actuating the APS pushbutton when the WALK interval is not timing. This verbal message shall be modeled after: "Wait. Wait to cross 'Street Name' at 'Street Name'".

Where two accessible pedestrian pushbuttons are separated by at least 10 ft (3 m), the walk indication shall be an audible percussive tone. It shall repeat at 8 to 10 ticks per second with a dominant frequency of 880 Hz.

Automatic volume adjustments in response to ambient traffic sound level shall be provided up to a maximum volume of 100 dBA. Locator tone and verbal messages shall be no more than 5 dB louder than ambient sound.

At locations with railroad interconnection, an additional speech message stating "Walk time shortened when train approaches" shall be used after the speech walk message. At locations with emergency vehicle preemption, an additional speech message "Walk time shortened when emergency vehicle approaches" shall be used after the speech walk message.

Pedestrian Pushbutton. Pedestrian pushbuttons shall be at least 2 in. (50 mm) in diameter or width. The force required to activate the pushbutton shall be no greater than 3.5 lb (15.5 N).

A red LED shall be located on or near the pushbutton which, when activated, acknowledges the pedestrians request to cross the street.

Signage. A sign shall be located immediately above the pedestrian pushbutton and parallel to the crosswalk controlled by the pushbutton. The sign shall conform to one of the following standard MUTCD designs: R10-3, R10-3a, R10-3e, R10-3i, R10-4, and R10-4a.

Tactile Arrow. A tactile arrow, pointing in the direction of travel controlled by a pushbutton, shall be provided on the pushbutton.

Vibrotactile Feature. The pushbutton shall pulse when depressed and shall vibrate continuously throughout the WALK interval.

Method of Measurement. This work will be measured for payment as each, per pushbutton.

Basis of Payment. This work will be paid for at the contract unit price per each for ACCESSIBLE PEDESTRIAN SIGNALS.

80099

## **STEEL COST ADJUSTMENT (BDE)**

Effective: April 2, 2004

Revised: November 1, 2025

Description. Steel cost adjustments will be made to provide additional compensation to the Contractor, or a credit to the Department, for fluctuations in steel prices when optioned by the Contractor. The bidder shall indicate with their bid whether or not this special provision will be part of the contract. Failure to indicate "Yes" for any item of work will make that item of steel exempt from steel cost adjustment.

Types of Steel Products. An adjustment will be made for fluctuations in the cost of steel used in the manufacture of the following items:

- Metal Piling (excluding temporary sheet piling)
- Structural Steel
- Reinforcing Steel

Other steel materials such as dowel bars, tie bars, welded reinforcement, guardrail, steel traffic signal and light poles, towers and mast arms, metal railings (excluding wire fence), and frames and grates will be subject to a steel cost adjustment when the pay items they are used in have a contract value of \$10,000 or greater.

The adjustments shall apply to the above items when they are part of the original proposed construction, or added as extra work and paid for by agreed unit prices. The adjustments shall not apply when the item is added as extra work and paid for at a lump sum price or by force account.

Documentation. The following documentation shall be furnished to the Engineer.

- (a) The dates and quantity of steel, in lb (kg), shipped from the mill to the fabricator.
- (b) The quantity of steel, in lb (kg), incorporated into the various items of work covered by this special provision. The Department reserves the right to verify submitted quantities.

Method of Adjustment. Steel cost adjustments will be computed as follows:

$$SCA = Q \times D$$

Where: SCA = steel cost adjustment, in dollars  
Q = quantity of steel incorporated into the work, in lb (kg)  
D = price factor, in dollars per lb (kg)

$$D = MPI_M - MPI_L$$

Where:  $MPI_M$  = The Materials Cost Index for steel as published by the Engineering News-Record for the month the steel is shipped from the mill. The indices will be converted from dollars per 100 lb to dollars per lb (kg).

$MPI_L$  = The Materials Cost Index for steel as published by the Engineering News-Record for the month prior to the letting for work paid for at the contract price; or for the month the agreed unit price letter is submitted by the Contractor for extra work paid for by agreed unit price. The indices will be converted from dollars per 100 lb to dollars per lb (kg).

The unit weights (masses) of steel that will be used to calculate the steel cost adjustment for the various items will be derived from submitted documentation.

No steel cost adjustment will be made for any products manufactured from steel having a mill shipping date prior to the letting date.

If the Contractor fails to provide the required documentation, the method of adjustment will be calculated as described above; however, the  $MPI_M$  will be based on the date the steel arrives at the job site. In this case, an adjustment will only be made when there is a decrease in steel costs.

Basis of Payment. Steel cost adjustments may be positive or negative but will only be made when there is a difference between the  $MPI_L$  and  $MPI_M$  in excess of five percent, as calculated by:

$$\text{Percent Difference} = \{(MPI_L - MPI_M) \div MPI_L\} \times 100$$

Steel cost adjustments will be calculated by the Engineer and will be paid or deducted when all other contract requirements for the items of work are satisfied. Adjustments will only be made for fluctuations in the cost of the steel as described herein. No adjustment will be made for changes in the cost of manufacturing, fabrication, shipping, storage, etc.

The adjustments shall not apply during contract time subject to liquidated damages for completion of the entire contract.

## BITUMINOUS MATERIALS COST ADJUSTMENTS (BDE)

Effective: November 2, 2006

Revised: August 1, 2017

Description. Bituminous material cost adjustments will be made to provide additional compensation to the Contractor, or credit to the Department, for fluctuations in the cost of bituminous materials when optioned by the Contractor. The bidder shall indicate with their bid whether or not this special provision will be part of the contract.

The adjustments shall apply to permanent and temporary hot-mix asphalt (HMA) mixtures, bituminous surface treatments (cover and seal coats), and preventative maintenance type surface treatments that are part of the original proposed construction, or added as extra work and paid for by agreed unit prices. The adjustments shall not apply to bituminous prime coats, tack coats, crack filling/sealing, joint filling/sealing, or extra work paid for at a lump sum price or by force account.

Method of Adjustment. Bituminous materials cost adjustments will be computed as follows.

$$CA = (BPI_P - BPI_L) \times (\%AC_V / 100) \times Q$$

Where: CA = Cost Adjustment, \$.

BPI<sub>P</sub> = Bituminous Price Index, as published by the Department for the month the work is performed, \$/ton (\$/metric ton).

BPI<sub>L</sub> = Bituminous Price Index, as published by the Department for the month prior to the letting for work paid for at the contract price; or for the month the agreed unit price letter is submitted by the Contractor for extra work paid for by agreed unit price, \$/ton (\$/metric ton).

%AC<sub>V</sub> = Percent of virgin Asphalt Cement in the Quantity being adjusted. For HMA mixtures, the % AC<sub>V</sub> will be determined from the adjusted job mix formula. For bituminous materials applied, a performance graded or cutback asphalt will be considered to be 100% AC<sub>V</sub> and undiluted emulsified asphalt will be considered to be 65% AC<sub>V</sub>.

Q = Authorized construction Quantity, tons (metric tons) (see below).

For HMA mixtures measured in square yards:  $Q, \text{ tons} = A \times D \times (G_{mb} \times 46.8) / 2000$ . For HMA mixtures measured in square meters:  $Q, \text{ metric tons} = A \times D \times (G_{mb} \times 1) / 1000$ . When computing adjustments for full-depth HMA pavement, separate calculations will be made for the binder and surface courses to account for their different  $G_{mb}$  and % AC<sub>V</sub>.

For bituminous materials measured in gallons:  $Q, \text{ tons} = V \times 8.33 \text{ lb/gal} \times SG / 2000$

For bituminous materials measured in liters:  $Q, \text{ metric tons} = V \times 1.0 \text{ kg/L} \times SG / 1000$

Where: A = Area of the HMA mixture, sq yd (sq m).

D = Depth of the HMA mixture, in. (mm).

$G_{mb}$  = Average bulk specific gravity of the mixture, from the approved mix design.

- V = Volume of the bituminous material, gal (L).  
SG = Specific Gravity of bituminous material as shown on the bill of lading.

Basis of Payment. Bituminous materials cost adjustments may be positive or negative but will only be made when there is a difference between the  $BPI_L$  and  $BPI_P$  in excess of five percent, as calculated by:

$$\text{Percent Difference} = \{(BPI_L - BPI_P) \div BPI_L\} \times 100$$

Bituminous materials cost adjustments will be calculated for each calendar month in which applicable bituminous material is placed; and will be paid or deducted when all other contract requirements for the work placed during the month are satisfied. The adjustments shall not apply during contract time subject to liquidated damages for completion of the entire contract.

80173

## **AUTOMATED FLAGGER ASSISTANCE DEVICES (BDE)**

Effective: January 1, 2008

Revised: April 1, 2023

Description. This work shall consist of furnishing and operating automated flagger assistance devices (AFADs) as part of the work zone traffic control and protection for two-lane highways where two-way traffic is maintained over one lane of pavement in segments where no sideroads or entrances require deployment of additional flaggers. Use of these devices shall be at the option of the Contractor.

Equipment. AFADs shall be the STOP/SLOW or Red/Yellow Lens type mounted on a trailer or moveable cart meeting the requirements of the MUTCD and NCHRP 350 or MASH 2016, Category 4.

General. AFADs shall be placed at each end of the traffic control, where a flagger is shown on the plans. The AFAD shall be setup within five degrees of vertical.

Flagger symbol signs as shown on the plans shall be replaced with "BE PREPARED TO STOP" signs when the AFAD is in operation.

Personal communication devices shall not be used to operate the AFAD.

Flagging Requirements. Flaggers and flagging requirements shall be according to Article 701.13 of the Standard Specifications and the following.

Each AFAD shall be operated by a flagger trained to operate the specific AFAD to be deployed. A minimum of two flaggers shall be on site at all times during operation. Each flagger shall be positioned outside the lane of traffic and near each AFAD's location.

Flagging equipment required for traditional flagging shall be available near each AFAD location in the event of AFAD equipment malfunction/failure.

For nighttime flagging, the AFAD and flagger shall be illuminated according to Article 701.13 of the Standard Specifications.

When not in use, AFADs will be considered non-operating equipment and shall be stored according to Article 701.11 of the Standard Specifications.

Basis of Payment. This work will not be paid for separately but shall be considered as included in the cost of the various traffic control items included in the contract.

All Regional Engineers

Scott E. Stitt

Special Provision for Completion Date (via calendar days)

January 14, 2011

This special provision was developed per the recommendations of an FHWA/IDOT Joint Process Review to establish a form of contract time which is based upon a set number of calendar days.

This special provision should be used at the district's discretion and per the guidance in Chapter 66 of the Bureau of Design and Environment Manual.

The districts should include the BDE Check Sheet marked with the applicable special provisions for the April 29, 2011, and subsequent lettings. The Project Development and Implementation Section will include a copy in the contract.

This special provision will be available on the transfer directory January 14, 2011.

80198m

**COMPLETION DATE (VIA CALENDAR DAYS) (BDE)**

Effective: April 1, 2008

The Contractor shall complete all work on or before the completion date of this contract which will be based upon \_\_\_\_\_ calendar days.

The completion date will be determined by adding the specified number of calendar days to the date the Contractor begins work, or to the date ten days after execution of the contract, whichever is the earlier, unless a delayed start is granted by the Engineer.

80198

All Regional Engineers

Scott E. Stitt

Special Provision for Completion Date (via calendar days) Plus  
Working Days

January 14, 2011

This special provision was developed per the recommendations of an FHWA/IDOT Joint Process Review to establish a form of contract time which is based upon a set number of calendar days.

This special provision should be used at the district's discretion and per the guidance in Chapter 66 of the Bureau of Design and Environment Manual.

The districts should include the BDE Check Sheet marked with the applicable special provisions for the April 29, 2011, and subsequent lettings. The Project Development and Implementation Section will include a copy in the contract.

This special provision will be available on the transfer directory January 14, 2011.

80199m

**COMPLETION DATE (VIA CALENDAR DAYS) PLUS WORKING DAYS (BDE)**

Effective: April 1, 2008

The Contractor shall complete \_\_\_\_\_ work on or before the completion date of this contract which will be based upon \_\_\_\_\_ calendar days. After the completion date, an additional working days will be allowed to complete \_\_\_\_\_ .

The completion date will be determined by adding the specified number of calendar days to the date the Contractor begins work, or to the date ten days after execution of the contract, whichever is the earlier, unless a delayed start is granted by the Engineer.

80199

## **FUEL COST ADJUSTMENT (BDE)**

Effective: April 1, 2009

Revised: August 1, 2017

Description. Fuel cost adjustments will be made to provide additional compensation to the Contractor, or a credit to the Department, for fluctuations in fuel prices when optioned by the Contractor. The bidder shall indicate with their bid whether or not this special provision will be part of the contract. Failure to indicate "Yes" for any category of work will make that category of work exempt from fuel cost adjustment.

General. The fuel cost adjustment shall apply to contract pay items as grouped by category. The adjustment shall only apply to those categories of work checked "Yes", and only when the cumulative plan quantities for a category exceed the required threshold. Adjustments to work items in a category, either up or down, and extra work paid for by agreed unit price will be subject to fuel cost adjustment only when the category representing the added work was subject to the fuel cost adjustment. Extra work paid for at a lump sum price or by force account will not be subject to fuel cost adjustment. Category descriptions and thresholds for application and the fuel usage factors which are applicable to each are as follows:

### (a) Categories of Work.

- (1) Category A: Earthwork. Contract pay items performed under Sections 202, 204, and 206 including any modified standard or nonstandard items where the character of the work to be performed is considered earthwork. The cumulative total of all applicable item plan quantities shall exceed 25,000 cu yd (20,000 cu m). Included in the fuel usage factor is a weighted average 0.10 gal/cu yd (0.50 liters/cu m) factor for trucking.
- (2) Category B: Subbases and Aggregate Base Courses. Contract pay items constructed under Sections 311, 312 and 351 including any modified standard or nonstandard items where the character of the work to be performed is considered construction of a subbase or aggregate, stabilized or modified base course. The cumulative total of all applicable item plan quantities shall exceed 5000 tons (4500 metric tons). Included in the fuel usage factor is a 0.60 gal/ton (2.50 liters/metric ton) factor for trucking.
- (3) Category C: Hot-Mix Asphalt (HMA) Bases, Pavements and Shoulders. Contract pay items constructed under Sections 355, 406, 407 and 482 including any modified standard or nonstandard items where the character of the work to be performed is considered HMA bases, pavements and shoulders. The cumulative total of all applicable item plan quantities shall exceed 5000 tons (4500 metric tons). Included in the fuel usage factor is 0.60 gal/ton (2.50 liters/metric ton) factor for trucking.
- (4) Category D: Portland Cement Concrete (PCC) Bases, Pavements and Shoulders. Contract pay items constructed under Sections 353, 420, 421 and 483 including any

modified standard or nonstandard items where the character of the work to be performed is considered PCC base, pavement or shoulder. The cumulative total of all applicable item plan quantities shall exceed 7500 sq yd (6000 sq m). Included in the fuel usage factor is 1.20 gal/cu yd (5.94 liters/cu m) factor for trucking.

- (5) Category E: Structures. Structure items having a cumulative bid price that exceeds \$250,000 for pay items constructed under Sections 502, 503, 504, 505, 512, 516 and 540 including any modified standard or nonstandard items where the character of the work to be performed is considered structure work when similar to that performed under these sections and not included in categories A through D.

(b) Fuel Usage Factors.

English Units		
Category	Factor	Units
A - Earthwork	0.34	gal / cu yd
B - Subbase and Aggregate Base courses	0.62	gal / ton
C - HMA Bases, Pavements and Shoulders	1.05	gal / ton
D - PCC Bases, Pavements and Shoulders	2.53	gal / cu yd
E - Structures	8.00	gal / \$1000

Metric Units		
Category	Factor	Units
A - Earthwork	1.68	liters / cu m
B - Subbase and Aggregate Base courses	2.58	liters / metric ton
C - HMA Bases, Pavements and Shoulders	4.37	liters / metric ton
D - PCC Bases, Pavements and Shoulders	12.52	liters / cu m
E - Structures	30.28	liters / \$1000

(c) Quantity Conversion Factors.

Category	Conversion	Factor
B	sq yd to ton	0.057 ton / sq yd / in depth
	sq m to metric ton	0.00243 metric ton / sq m / mm depth
C	sq yd to ton	0.056 ton / sq yd / in depth
	sq m to metric ton	0.00239 m ton / sq m / mm depth
D	sq yd to cu yd	0.028 cu yd / sq yd / in depth
	sq m to cu m	0.001 cu m / sq m / mm depth

Method of Adjustment. Fuel cost adjustments will be computed as follows.

$$CA = (FPI_P - FPI_L) \times FUF \times Q$$

Where: CA = Cost Adjustment, \$  
FPI<sub>P</sub> = Fuel Price Index, as published by the Department for the month the work is performed, \$/gal (\$/liter)  
FPI<sub>L</sub> = Fuel Price Index, as published by the Department for the month prior to the letting for work paid for at the contract price; or for the month the agreed unit price letter is submitted by the Contractor for extra work paid for by agreed unit price, \$/gal (\$/liter)  
FUF = Fuel Usage Factor in the pay item(s) being adjusted  
Q = Authorized construction Quantity, tons (metric tons) or cu yd (cu m)

The entire FUF indicated in paragraph (b) will be used regardless of use of trucking to perform the work.

Basis of Payment. Fuel cost adjustments may be positive or negative but will only be made when there is a difference between the FPI<sub>L</sub> and FPI<sub>P</sub> in excess of five percent, as calculated by:

$$\text{Percent Difference} = \{(FPI_L - FPI_P) \div FPI_L\} \times 100$$

Fuel cost adjustments will be calculated for each calendar month in which applicable work is performed; and will be paid or deducted when all other contract requirements for the items of work are satisfied. The adjustments shall not apply during contract time subject to liquidated damages for completion of the entire contract.

All Regional Engineers

Charles J. Ingersoll

Special Provision for Bridge Demolition Debris

April 17, 2009

This special provision was developed by the Bureau of Design to comply with Federal Public Law 109-59, Section 1805 which requires the department to first make the debris from the demolition of bridges available for beneficial use by Federal, State, or local government, unless such use obstructs navigation.

It should be inserted in contracts in which a unit of local government has expressed interest in the debris and has coordinated with the District Bureau of Local Roads and Streets.

The districts should include the BDE Check Sheet marked with the applicable special provisions for the July 31, 2009 and subsequent lettings. The Project Development and Implementation Section will include a copy in the contract.

This special provision will be available on the transfer directory April 17, 2009.

80241m

## **BRIDGE DEMOLITION DEBRIS (BDE)**

Effective: July 1, 2009

The debris from removing structure number \_\_\_\_\_ shall be delivered to \_\_\_\_\_ (agency name), located at \_\_\_\_\_ (address), \_\_\_\_\_ miles from the jobsite. For description of debris to be salvaged, the Contractor shall contact \_\_\_\_\_ (agency contact person and phone number). The Contractor shall coordinate delivery of the debris to the designated location, at no additional cost to the Department. Upon receipt of the debris, the receiving agency shall be responsible for additional costs of processing, delivery placement and use of the material and shall assume legal and permitting responsibility for the placement of the debris. Payment for delivery of the debris to the designated location shall be included in the cost for removal of existing structures.

80241

## CONSTRUCTION AIR QUALITY – DIESEL RETROFIT (BDE)

Effective: June 1, 2010

Revised: January 1, 2025

The reduction of emissions of particulate matter (PM) for off-road equipment shall be accomplished by installing retrofit emission control devices. The term “equipment” refers to diesel fuel powered devices rated at 50 hp and above, to be used on the jobsite in excess of seven calendar days over the course of the construction period on the jobsite (including rental equipment).

Contractor and subcontractor diesel powered off-road equipment assigned to the contract shall be retrofitted according to the table below.

Horsepower Range	Model Year and Older
50-99	2003
100-299	2002
300-599	2000
600-749	2001
750 and up	2005

The retrofit emission control devices shall achieve a minimum PM emission reduction of 50 percent and shall be:

- a) Included on the U.S. Environmental Protection Agency (USEPA) *Verified Retrofit Technology List* (<https://www.epa.gov/verified-diesel-tech/verified-technologies-list-clean-diesel>), or verified by the California Air Resources Board (CARB) (<http://www.arb.ca.gov/diesel/verdev/vt/cvt.htm>); or
- b) Retrofitted with a non-verified diesel retrofit emission control device if verified retrofit emission control devices are not available for equipment proposed to be used on the project, and if the Contractor has obtained a performance certification from the retrofit device manufacturer that the emission control device provides a minimum PM emission reduction of 50 percent.

Note: Large cranes (Crawler mounted cranes) which are responsible for critical lift operations are exempt from installing retrofit emission control devices if such devices adversely affect equipment operation.

Diesel powered off-road equipment with engine ratings of 50 hp and above, which are unable to be retrofitted with verified emission control devices or if performance certifications are not available which will achieve a minimum 50 percent PM reduction, may be granted a waiver by the Department if documentation is provided showing good faith efforts were made by the Contractor to retrofit the equipment.

Construction shall not proceed until the Contractor submits a certified list of the diesel powered off-road equipment that will be used, and as necessary, retrofitted with emission control devices. The list(s) shall include (1) the equipment number, type, make, Contractor/rental company name; and (2) the emission control devices make, model, USEPA or CARB verification number, or performance certification from the retrofit device manufacturer. Equipment reported as fitted with emissions control devices shall be made available to the Engineer for visual inspection of the device installation, prior to being used on the jobsite.

The Contractor shall submit an updated list of retrofitted off-road construction equipment as retrofitted equipment changes or comes on to the jobsite. The addition or deletion of any diesel powered equipment shall be included on the updated list.

If any diesel powered off-road equipment is found to be in non-compliance with any portion of this special provision, the Engineer will issue the Contractor a diesel retrofit deficiency deduction.

Any costs associated with retrofitting any diesel powered off-road equipment with emission control devices shall be considered as included in the contract unit prices bid for the various items of work involved and no additional compensation will be allowed. The Contractor's compliance with this notice and any associated regulations shall not be grounds for a claim.

### **Diesel Retrofit Deficiency Deduction**

When the Engineer determines that a diesel retrofit deficiency exists, a daily monetary deduction will be imposed for each calendar day or fraction thereof the deficiency continues to exist. The calendar day(s) will begin when the time period for correction is exceeded and end with the Engineer's written acceptance of the correction. The daily monetary deduction will be \$1,000.00 for each deficiency identified.

The deficiency will be based on lack of diesel retrofit emissions control.

If a Contractor accumulates three diesel retrofit deficiency deductions for the same piece of equipment in a contract period, the Contractor will be shutdown until the deficiency is corrected. Such a shutdown will not be grounds for any extension of the contract time, waiver of penalties, or be grounds for any claim.

## AGGREGATE SUBGRADE IMPROVEMENT (BDE)

Effective: April 1, 2012

Revised: April 1, 2022

Add the following Section to the Standard Specifications:

### “SECTION 303. AGGREGATE SUBGRADE IMPROVEMENT

**303.01 Description.** This work shall consist of constructing an aggregate subgrade improvement (ASI).

**303.02 Materials.** Materials shall be according to the following.

Item	Article/Section
(a) Coarse Aggregate .....	1004.07
(b) Reclaimed Asphalt Pavement (RAP) .....	1031.09

**303.03 Equipment.** The vibratory roller shall be according to Article 1101.01, or as approved by the Engineer. Vibratory machines, such as tampers, shall be used in areas where rollers do not fit.

**303.04 Soil Preparation.** The minimum immediate bearing value (IBV) of the soil below the improved subgrade shall be according to the Department’s “Subgrade Stability Manual” for the aggregate thickness specified.

**303.05 Placing and Compacting.** The maximum nominal lift thickness of aggregate gradations CA 2, CA 6, and CA 10 when compacted shall be 9 in. (225 mm). The maximum nominal lift thickness of aggregate gradations CS 1, CS 2, and RR 1 when compacted shall be 24 in. (600 mm).

The top surface of the aggregate subgrade improvement shall consist of a layer of capping aggregate gradations CA 6 or CA 10 that is 3 in. (75 mm) thick after compaction. Capping aggregate will not be required when aggregate subgrade improvement is used as a cubic yard pay item for undercut applications.

Each lift of aggregate shall be compacted to the satisfaction of the Engineer. If the moisture content of the material is such that compaction cannot be obtained, sufficient water shall be added so that satisfactory compaction can be obtained.

**303.06 Finishing and Maintenance.** The aggregate subgrade improvement shall be finished to the lines, grades, and cross sections shown on the plans, or as directed by the Engineer. The aggregate subgrade improvement shall be maintained in a smooth and compacted condition.

**303.07 Method of Measurement.** This work will be measured for payment according to Article 311.08.

**303.08 Basis of Payment.** This work will be paid for at the contract unit price per cubic yard (cubic meter) or ton (metric ton) for AGGREGATE SUBGRADE IMPROVEMENT or at the contract unit price per square yard (square meter) for AGGREGATE SUBGRADE IMPROVEMENT, of the thickness specified.”

Add the following to Section 1004 of the Standard Specifications:

**“1004.07 Coarse Aggregate for Aggregate Subgrade Improvement (ASI).** The aggregate shall be according to Article 1004.01 and the following.

(a) Description. The coarse aggregate shall be crushed gravel, crushed stone, or crushed concrete. In applications where greater than 24 in. (600 mm) of ASI material is required, gravel may be used below the top 12 in (300 mm) of ASI.

(b) Quality. The coarse aggregate shall consist of sound durable particles reasonably free of deleterious materials.

(c) Gradation.

(1) The coarse aggregate gradation for total ASI thickness less than or equal to 12 in. (300 mm) shall be CA 2, CA 6, CA 10, or CS 1.

The coarse aggregate gradation for total ASI thickness greater than 12 in. (300 mm) shall be CS 1 or CS 2 as shown below or RR 1 according to Article 1005.01(c).

COARSE AGGREGATE SUBGRADE GRADATIONS					
Grad No.	Sieve Size and Percent Passing				
	8”	6”	4”	2”	#4
CS 1	100	97 ± 3	90 ± 10	45 ± 25	20 ± 20
CS 2		100	80 ± 10	25 ± 15	

COARSE AGGREGATE SUBGRADE GRADATIONS (Metric)					
Grad No.	Sieve Size and Percent Passing				
	200 mm	150 mm	100 mm	50 mm	4.75 mm
CS 1	100	97 ± 3	90 ± 10	45 ± 25	20 ± 20
CS 2		100	80 ± 10	25 ± 15	

(2) Capping aggregate shall be gradation CA 6 or CA 10.”

Add the following to Article 1031.09 of the Standard Specifications:

“(b) RAP in Aggregate Subgrade Improvement (ASI). RAP in ASI shall be according to Articles 1031.01(a), 1031.02(a), 1031.06(a)(1), and 1031.06(a)(2), and the following.

- (1) The testing requirements of Article 1031.03 shall not apply.
- (2) Crushed RAP used for the lower lift may be mechanically blended with aggregate gradations CS 1, CS 2, and RR 1 but it shall be no greater than 40 percent of the total product volume. RAP agglomerations shall be no greater than 4 in. (100 mm).
- (3) For capping aggregate, well graded RAP having 100 percent passing the 1 1/2 in. (38 mm) sieve may be used when aggregate gradations CS 1, CS 2, CA 2, or RR 1 are used in the lower lift. FRAP will not be permitted as capping material.

Blending shall be through calibrated interlocked feeders or a calibrated blending plant such that the prescribed blending percentage is maintained throughout the blending process. The calibration shall have an accuracy of  $\pm 2.0$  percent of the actual quantity of material delivered.”

## **WEEKLY DBE TRUCKING REPORTS (BDE)**

Effective: June 2, 2012

Revised: January 2, 2025

The following applies to all Disadvantaged Business Enterprise (DBE) trucks on the project, whether they are utilized for DBE goal credit or not.

The Contractor shall notify the Engineer at least three days prior to DBE trucking activity.

The Contractor shall submit a weekly report of DBE trucks hired by the Contractor or subcontractors (i.e. not owned by the Contractor or subcontractors) to the Engineer on Department form "SBE 723" within ten business days following the reporting period. The reporting period shall be Sunday through Saturday for each week reportable trucking activities occur.

Any costs associated with providing weekly DBE trucking reports shall be considered as included in the contract unit prices bid for the various items of work involved and no additional compensation will be allowed.

80302

## **SPEED DISPLAY TRAILER (BDE)**

Effective: April 2, 2014

Revised: January 1, 2022

Revise the last paragraph of Article 701.11 of the Standard Specifications to read:

“When not being utilized to inform and direct traffic, sign trailers, speed display trailers, arrow boards, and portable changeable message boards shall be treated as nonoperating equipment.”

Add the following to Article 701.15 of the Standard Specifications:

“(m) Speed Display Trailer. A speed display trailer is used to enhance safety of the traveling public and workers in work zones by alerting drivers of their speed, thus deterring them from driving above the posted work zone speed limit.”

Add the following to Article 701.20 of the Standard Specifications:

“(k) When speed display trailers are shown on the Standard, this work will not be paid for separately but shall be considered as included in the cost of the Standard.

For all other speed display trailers, this work will be paid for at the contract unit price per calendar month or fraction thereof for each trailer as SPEED DISPLAY TRAILER.”

Add the following to Article 1106.02 of the Standard Specifications:

“(o) Speed Display Trailer. The speed display trailer shall consist of a LED speed indicator display with self-contained, one-direction radar mounted on an orange see-through trailer. The height of the display and radar shall be such that it will function and be visible when located behind concrete barrier.

The speed measurement shall be by radar and provide a minimum detection distance of 1000 ft (300 m). The radar shall have an accuracy of  $\pm 1$  mile per hour.

The speed indicator display shall face approaching traffic and shall have a sign legend of “YOUR SPEED” immediately above or below the speed display. The sign letters shall be between 5 and 8 in. (125 and 200 mm) in height. The digital speed display shall show two digits (00 to 99) in mph. The color of the changeable message legend shall be a yellow legend on a black background. The minimum height of the numerals shall be 18 in. (450 mm), and the nominal legibility distance shall be at least 750 ft (250 m).

The speed indicator display shall be equipped with a violation alert that flashes the displayed detected speed when the work zone posted speed limit is exceeded. The speed indicator shall have a maximum speed cutoff. On roadway facilities with a normal posted speed limit greater than or equal to 45 mph, the detected speeds of vehicles traveling more than 25 mph over the work zone speed limit shall not be displayed. On facilities with normal posted speed limit of less than 45 mph, the detected speeds of vehicles traveling more than 15 mph over the work zone speeds limit shall not be

displayed. On any roadway facility if detected speeds are less than 25 mph, they shall not be displayed. The display shall include automatic dimming for nighttime operation.

The speed indicator measurement and display functions shall be equipped with the power supply capable of providing 24 hours of uninterrupted service.”

80340

## **COMPENSABLE DELAY COSTS (BDE)**

Effective: June 2, 2017

Revised: April 1, 2019

Revise Article 107.40(b) of the Standard Specifications to read:

“(b) Compensation. Compensation will not be allowed for delays, inconveniences, or damages sustained by the Contractor from conflicts with facilities not meeting the above definition; or if a conflict with a utility in an unanticipated location does not cause a shutdown of the work or a documentable reduction in the rate of progress exceeding the limits set herein. The provisions of Article 104.03 notwithstanding, compensation for delays caused by a utility in an unanticipated location will be paid according to the provisions of this Article governing minor and major delays or reduced rate of production which are defined as follows.

- (1) Minor Delay. A minor delay occurs when the work in conflict with the utility in an unanticipated location is completely stopped for more than two hours, but not to exceed two weeks.
- (2) Major Delay. A major delay occurs when the work in conflict with the utility in an unanticipated location is completely stopped for more than two weeks.
- (3) Reduced Rate of Production Delay. A reduced rate of production delay occurs when the rate of production on the work in conflict with the utility in an unanticipated location decreases by more than 25 percent and lasts longer than seven calendar days.”

Revise Article 107.40(c) of the Standard Specifications to read:

“(c) Payment. Payment for Minor, Major, and Reduced Rate of Production Delays will be made as follows.

- (1) Minor Delay. Labor idled which cannot be used on other work will be paid for according to Article 109.04(b)(1) and (2) for the time between start of the delay and the minimum remaining hours in the work shift required by the prevailing practice in the area.

Equipment idled which cannot be used on other work, and which is authorized to standby on the project site by the Engineer, will be paid for according to Article 109.04(b)(4).

- (2) Major Delay. Labor will be the same as for a minor delay.

Equipment will be the same as for a minor delay, except Contractor-owned equipment will be limited to two weeks plus the cost of move-out to either the

Contractor's yard or another job and the cost to re-mobilize, whichever is less. Rental equipment may be paid for longer than two weeks provided the Contractor presents adequate support to the Department (including lease agreement) to show retaining equipment on the job is the most economical course to follow and in the public interest.

- (3) Reduced Rate of Production Delay. The Contractor will be compensated for the reduced productivity for labor and equipment time in excess of the 25 percent threshold for that portion of the delay in excess of seven calendar days. Determination of compensation will be in accordance with Article 104.02, except labor and material additives will not be permitted.

Payment for escalated material costs, escalated labor costs, extended project overhead, and extended traffic control will be determined according to Article 109.13.”

Revise Article 108.04(b) of the Standard Specifications to read:

“(b) No working day will be charged under the following conditions.

- (1) When adverse weather prevents work on the controlling item.
- (2) When job conditions due to recent weather prevent work on the controlling item.
- (3) When conduct or lack of conduct by the Department or its consultants, representatives, officers, agents, or employees; delay by the Department in making the site available; or delay in furnishing any items required to be furnished to the Contractor by the Department prevents work on the controlling item.
- (4) When delays caused by utility or railroad adjustments prevent work on the controlling item.
- (5) When strikes, lock-outs, extraordinary delays in transportation, or inability to procure critical materials prevent work on the controlling item, as long as these delays are not due to any fault of the Contractor.
- (6) When any condition over which the Contractor has no control prevents work on the controlling item.”

Revise Article 109.09(f) of the Standard Specifications to read:

“(f) Basis of Payment. After resolution of a claim in favor of the Contractor, any adjustment in time required for the work will be made according to Section 108. Any adjustment in the costs to be paid will be made for direct labor, direct materials, direct equipment, direct jobsite overhead, direct offsite overhead, and other direct costs allowed by the resolution. Adjustments in costs will not be made for interest charges, loss of anticipated profit, undocumented loss of efficiency, home office overhead and unabsorbed overhead

other than as allowed by Article 109.13, lost opportunity, preparation of claim expenses and other consequential indirect costs regardless of method of calculation.

The above Basis of Payment is an essential element of the contract and the claim cost recovery of the Contractor shall be so limited.”

Add the following to Section 109 of the Standard Specifications.

**“109.13 Payment for Contract Delay.** Compensation for escalated material costs, escalated labor costs, extended project overhead, and extended traffic control will be allowed when such costs result from a delay meeting the criteria in the following table.

Contract Type	Cause of Delay	Length of Delay
Working Days	Article 108.04(b)(3) or Article 108.04(b)(4)	No working days have been charged for two consecutive weeks.
Completion Date	Article 108.08(b)(1) or Article 108.08(b)(7)	The Contractor has been granted a minimum two week extension of contract time, according to Article 108.08.

Payment for each of the various costs will be according to the following.

- (a) Escalated Material and/or Labor Costs. When the delay causes work, which would have otherwise been completed, to be done after material and/or labor costs have increased, such increases will be paid. Payment for escalated material costs will be limited to the increased costs substantiated by documentation furnished by the Contractor. Payment for escalated labor costs will be limited to those items in Article 109.04(b)(1) and (2), except the 35 percent and 10 percent additives will not be permitted.
- (b) Extended Project Overhead. For the duration of the delay, payment for extended project overhead will be paid as follows.
  - (1) Direct Jobsite and Offsite Overhead. Payment for documented direct jobsite overhead and documented direct offsite overhead, including onsite supervisory and administrative personnel, will be allowed according to the following table.

Original Contract Amount	Supervisory and Administrative Personnel
Up to \$5,000,000	One Project Superintendent
Over \$ 5,000,000 - up to \$25,000,000	One Project Manager, One Project Superintendent or Engineer, and One Clerk
Over \$25,000,000 - up to \$50,000,000	One Project Manager, One Project Superintendent, One Engineer, and

	One Clerk
Over \$50,000,000	One Project Manager, Two Project Superintendents, One Engineer, and One Clerk

(2) Home Office and Unabsorbed Overhead. Payment for home office and unabsorbed overhead will be calculated as 8 percent of the total delay cost.

(c) Extended Traffic Control. Traffic control required for an extended period of time due to the delay will be paid for according to Article 109.04.

When an extended traffic control adjustment is paid under this provision, an adjusted unit price as provided for in Article 701.20(a) for increase or decrease in the value of work by more than ten percent will not be paid.

Upon payment for a contract delay under this provision, the Contractor shall assign subrogation rights to the Department for the Department's efforts of recovery from any other party for monies paid by the Department as a result of any claim under this provision. The Contractor shall fully cooperate with the Department in its efforts to recover from another party any money paid to the Contractor for delay damages under this provision."

## **SUBCONTRACTOR MOBILIZATION PAYMENTS (BDE)**

Effective: November 2, 2017

Revised: April 1, 2019

Replace the second paragraph of Article 109.12 of the Standard Specifications with the following:

“This mobilization payment shall be made at least seven days prior to the subcontractor starting work. The amount paid shall be at the following percentage of the amount of the subcontract reported on form BC 260A submitted for the approval of the subcontractor’s work.

Value of Subcontract Reported on Form BC 260A	Mobilization Percentage
Less than \$10,000	25%
\$10,000 to less than \$20,000	20%
\$20,000 to less than \$40,000	18%
\$40,000 to less than \$60,000	16%
\$60,000 to less than \$80,000	14%
\$80,000 to less than \$100,000	12%
\$100,000 to less than \$250,000	10%
\$250,000 to less than \$500,000	9%
\$500,000 to \$750,000	8%
Over \$750,000	7%”

80391

## **SUBCONTRACTOR AND DBE PAYMENT REPORTING (BDE)**

Effective: April 2, 2018

Add the following to Section 109 of the Standard Specifications.

**“109.14 Subcontractor and Disadvantaged Business Enterprise Payment Reporting.**  
The Contractor shall report all payments made to the following parties:

- (a) first tier subcontractors;
- (b) lower tier subcontractors affecting disadvantaged business enterprise (DBE) goal credit;
- (c) material suppliers or trucking firms that are part of the Contractor’s submitted DBE utilization plan.

The report shall be made through the Department’s on-line subcontractor payment reporting system within 21 days of making the payment.”

80397

## BITUMINOUS SURFACE TREATMENT WITH FOG SEAL (BDE)

Effective: January 1, 2020

Revised: April 1, 2026

Replace Section 403 of the Standard Specifications with the following:

### “SECTION 403. BITUMINOUS SURFACE TREATMENT WITH FOG SEAL

**403.01 Description.** This work shall consist of constructing a single or multiple course bituminous surface treatment with fog seal.

- (a) A-1. A-1 shall consist of an emulsified asphalt and a seal coat aggregate with an emulsified asphalt fog seal.
- (b) A-2. A-2 shall consist of an emulsified asphalt and a cover coat aggregate, and an emulsified asphalt and seal coat aggregate with an emulsified asphalt fog seal.
- (c) A-3. A-3 shall consist of two separate applications of an emulsified asphalt and cover coat aggregate, and an emulsified asphalt and seal coat aggregate with an emulsified asphalt fog seal.

**403.02 Materials.** Materials shall be according to the following.

Item	Article/Section
(a) Cover Coat Aggregate (Note 1) .....	1004.03
(b) Seal Coat Aggregate (Note 1) .....	1004.03
(c) Emulsified Asphalts (Note 2) (Note 3) .....	1032

Note 1. The coarse aggregate shall be crushed gravel, crushed stone, wet bottom boiler slag, crushed slag, crushed sandstone, or crushed steel slag. The coarse aggregate material shall be selected from the table in Article 1004.03(a) based upon the friction aggregate mixture specified. The aggregate quality shall be Class B and the total chert count shall be no more than 25.0 percent by weight (mass) as determined by the ITP 203. The cover coat aggregate gradation shall be CA 14 or CA 15, as specified on the plans. The seal coat aggregate gradation shall be CA 16 or CA 20, as specified on the plans. The gradations for both cover coat and seal coat aggregates shall contain a maximum of 2.0 percent Minus No. 200 material.

Note 2. The emulsified asphalt used to construct the bituminous surface treatment shall be either CRS-2P or HFRS-2P.

Note 3. The emulsified asphalt used to construct the fog seal shall be either SS-1h or CSS-1h.

**403.03 Equipment.** Equipment shall be according to the following.

Item	Article/Section
(a) Self-Propelled Pneumatic-Tired Roller (Note 1) .....	1101.01
(b) Mechanical Sweeper (Note 2) .....	1101.03
(c) Aggregate Spreaders (Note 3) .....	1102.04
(d) General Use Pressure Distributor (Note 4) .....	1102.05(a)
(e) Heating Equipment .....	1102.07

Note 1. There shall be a minimum of two rollers, with the final number of rollers determined by the rollers' abilities to maintain proper spacing with the aggregate spreader as directed by the Engineer.

Note 2. The mechanical sweeper shall be power driven and self-propelled with the broom located between the axles. The mechanical sweeper shall not use a cantilever-mounted broom and the broom rotation shall not be operated by forward movement.

Note 3. The aggregate spreader shall be a self-propelled mechanical type with the receiving hopper in the rear and shall pull the aggregate truck. The spreader shall be fitted with an automated system which provides positive interconnected control of the aggregate flow with the forward speed of the spreader. The automated system shall provide uniform and consistent aggregate application at the rate specified.

The Engineer will check the spread roll of the aggregate spreader for straightness each day before operations begin. Should the surface of the spread roll vary off a straight line along its longitudinal dimension by more than 1/16 in. (1.5 mm), the Engineer will inspect the application of aggregate for corrugations and, should these occur, the machine shall be repaired or replaced. The forward speed of the spreader during calibration shall be the same as is to be used during construction. The equipment required for aggregate spreader calibration may consist of several sheets of canvas, each being exactly 1 sq yd (0.8 sq m), and a weight scale. By making several runs at different gate openings over the sheets of canvas, placed to cover the full width applied by the spreader, and carefully measuring the aggregate on each canvas sheet, the gate opening at the pre-established speed required to apply aggregate at the specified rate may be determined.

Note 4. The general use pressure distributor shall have a minimum capacity of 3000 gal (11,500 L). The application rate control shall be automated and shall control the application rate regardless of ground speed or spray bar width. The computer shall have the capability of recording the application rate, gallons sprayed, square yards, and feet traveled. The general use pressure distributor shall be capable of maintaining the asphalt emulsion at the specified temperature. The spray bar nozzles shall produce a uniform triple lap application fan spray, and the shutoff shall be instantaneous, with no dripping. The general use pressure distributor shall be capable of maintaining the specified application rate within  $\pm 0.015$  gal/sq yd ( $\pm 0.070$  L/sq m) for each load. The spray-bar nozzles shall be turned to make the same angle with the longitudinal axis of the spray bar as recommended by the manufacturer.

Application rates shall be determined by the procedures listed in ASTM D 2995, except the sample may be taken on three 8 x 12 in. (200 x 300 mm) metal plates. The three plates shall be positioned as directed by the Engineer.

## CONSTRUCTION REQUIREMENTS

**403.04 Weather Limitations.** This work shall be done between May 1 and August 31. Emulsified asphalt shall be applied only when the temperature of the air in the shade is above 55 °F (13 °C). No work shall be started if local conditions indicate that rain is imminent.

Fog seal operations shall be performed during daylight hours and not during foggy weather. The road surface may be damp but shall be free of standing water.

This work may be done between September 1 and September 15 provided both of the following conditions are met:

- (a) The temperature of the air in the shade is above 70 °F (20 °C) and the temperature of the surface to which the asphalt will be applied is 70 °F (20 °C) or above, and
- (b) The National Weather Service forecast for the area does not show any rain or any temperatures below 55 °F (13 °C) for the day the work is to be done or for the following five days.

**403.05 Mix Design.** Prior to beginning work, the Contractor shall submit designs for each required mixture to the Department for verification and approval. The mixture design shall be performed at a laboratory accredited for pavement preservation testing by AASHTO re:source in addition to the following.

The bituminous surface treatment design shall be according to the Bureau of Research's (BR) PT003 "Bituminous Surface Treatment Design Form". A minimum of four weeks prior to beginning construction, aggregate samples used in the proposed designs shall be submitted to the Central Bureau of Materials for verification and approval of the application rates. The sample quantities shall be 20 ± 5 lbs (9 ± 2 kg).

The Department will verify the samples and application rates according to the following acceptable limits.

AASHTO R 102	
Material	Acceptable Limits
Aggregate	± 1.0%
Emulsified Asphalt	± 0.5%

After the mix design is approved, no substitutions will be permitted unless approved by the Engineer.

**403.06 Repair and Preparation of Base or Existing Surface.** The base or existing surface shall be prepared according to Section 358.

**403.07 Calibration.** At least three days prior to starting the work, the Contractor shall provide the Engineer with a copy of the manufacturer's recommendations for the equipment to be used. The working day prior to starting construction, the general use pressure distributor and aggregate spreader shall be calibrated and adjusted according to the manufacturer's recommendations. Calibrations and adjustments shall be made in the presence of the Engineer on a level surface at a location approved by the Engineer. The Contractor shall maintain proper calibration and adjustment of the equipment and the Engineer reserves the right to check application rates as the work progresses. Should the equipment fail to consistently apply the specified rates, the work shall be stopped, and the Contractor shall recalibrate and readjust the equipment.

**403.08 Preparation of Emulsified Asphalt.** The temperature of the emulsified asphalt at the time of application shall be such that it sprays uniformly without clogging the spraying nozzles and is applied within the temperature range of 150 – 190 °F (65 – 90 °C).

**403.09 Preparation of Aggregate.** The aggregate shall be stockpiled near the jobsite according to Article 1003.01(e) or 1004.01(e). The aggregate used shall contain no free moisture, but the aggregate shall be slightly damp (saturated surface-dry or drier).

**403.10 Application of Emulsified Asphalt.** The emulsified asphalt shall be applied with a general use pressure distributor. The entire length of the spray bar shall be set at the height above the surface recommended by the manufacturer for even distribution of the emulsified asphalt. A hand spray bar shall be used at locations not covered by the distributor.

The distributor shall be operated in a manner such that missing or overlapping of transverse joints shall be avoided. To prevent overlapping of successive applications of emulsified asphalt at transverse joints, heavy paper shall be spread over the previously applied emulsified asphalt and aggregates. In order to obtain a uniform application of the emulsified asphalt, the distributor shall be traveling at the speed required for the specified rate of application when the spray bar crosses the paper.

Adjacent construction, such as concrete pavement, curb and gutter, bridge floors, raised reflective pavement markers, and bridge handrails, shall be protected by shields, covers or other means. If emulsified asphalt is applied to adjacent construction, the Contractor shall remove such material to the satisfaction of the Engineer.

The emulsified asphalt shall not be applied when the wind conditions will inhibit uniform coverage from the fans of asphalt being applied.

**403.11 Application of Aggregates.** The cover and seal coat aggregates shall be spread evenly with an aggregate spreader over the entire surface being treated. When treating one-half of the pavement width at a time, an inside strip of uncovered emulsified asphalt 3 in. (75 mm) wide shall be left during construction of the first half to provide center joint overlap when the second half of the treatment is placed. In all cases, the aggregate shall be applied ahead of the

truck or spreader wheels. Hand spreading will be permitted only when approved by the Engineer and, when so permitted, the aggregate shall be spread uniformly and at the approximate rate specified. Any ridges of aggregate left by the aggregate spreader shall be smoothed out with hand brooms immediately behind the aggregate spreader.

Equipment involved in the work shall operate as close to each other as practical. The aggregate spreader shall be within 150 ft (45 m) of the pressure distributor and the aggregate shall cover the asphalt emulsion within 30 seconds of application to ensure proper asphalt/aggregate adhesion.

Each aggregate truck shall be equipped with a suitable hitch for connection to the aggregate spreader while unloading. The trucks shall avoid contact between the truck body or bed and the aggregate spreader. The body or bed of the truck shall be modified, if necessary, to empty cleanly and completely into the receiving hopper of the aggregate spreader. No aggregate shall be allowed to spill onto the road surface when the truck is emptying into this hopper.

**403.12 Cover Coat.** Emulsified asphalt for the cover coat shall not be applied until the previous application is acceptable to the Engineer.

At the beginning of each day's work, no emulsified asphalt shall be applied until there is sufficient cover coat aggregate in the trucks at the work site to completely cover the first application of asphalt emulsion. The amount of surface area covered by each successive application of emulsified asphalt shall be determined by the Engineer. In no case shall this area be greater than can be covered with cover coat aggregate and given the initial rolling while the emulsified asphalt is still in condition to hold aggregate.

The emulsified asphalt shall be applied uniformly over the surface at the rate specified in the table above. Immediately following the application of the asphalt emulsion, the cover coat aggregate shall be spread over the treated surface at the rate specified in the table above.

The aggregate shall be rolled following spreading. A maximum time of five minutes will be allowed between the spreading of aggregate and completion of the initial rolling of the aggregate. The rollers shall proceed in a longitudinal direction at a speed less than or equal to 5 mph (8 km/h). Each roller will travel over the aggregate a minimum of two times. The entire surface shall be rolled immediately with a self-propelled pneumatic-tired roller. Rolling shall proceed in a longitudinal direction beginning at the edges and progressing toward the center, overlapping on successive trips by at least 1/2 the width of the roller. The aggregate shall then be rolled with a separate pneumatic-tired roller until the aggregate is properly seated in the asphalt emulsion.

**403.13 Seal Coat.** When constructing an A-2 or A-3 treatment, the seal coat shall not be started until the cover coat immediately preceding the seal coat is completed.

Application of the emulsified asphalt and aggregate and rolling of the seal coat shall be the same as specified above for the cover coat.

During the construction period, the Contractor shall maintain the completed work. If necessary, the Contractor shall apply additional seal coat aggregate to absorb excess bitumen appearing on the surface and shall repair any areas where pickup has occurred.

The Contractor shall use the appropriate sweeping equipment to perform an initial sweeping after a minimum of two hours curing and not less than one hour before sunset on the day the bituminous surface treatment is placed. The initial sweeping shall remove excess aggregate by lightly sweeping each pavement lane. The sweeping shall be sufficient to prevent migration of loose aggregate back onto any part of the pavement.

The Contractor shall sweep the pavement surface as needed to remove excess aggregate.

**403.14 Application of Fog Seal.** The emulsified asphalt for the fog seal shall not be applied to the treated surface until the seal coat has cured for at least 24 hours.

The emulsified asphalt shall be applied uniformly and at a rate that will provide a residual asphalt rate on the prepared surface of 0.03 to 0.08 lb/sq ft (0.146 to 0.391 kg/sq m). An application rate greater than 0.05 lb/sq ft (0.244 kg/sq m) shall be applied in two passes, one from each direction. The Contractor shall demonstrate the application will produce 100 percent coverage of the surface after curing. If the application demonstration does not meet the coverage requirements, the spray pattern shall be adjusted until approved by the Engineer. The emulsified asphalt shall be applied in a manner to minimize the amount of overspray.

A check shall be performed in the first 1,000 ft (300 m) to verify the application rate according to the test procedure for "Determination of Residual Asphalt in Prime and Tack Coat Materials".

**403.15 Opening to Traffic.** The road shall be opened to traffic according to Article 701.17(c)(4).

**403.16 Method of Measurement.** The bituminous surface treatment (A-1, A-2, or A-3) will be measured for payment in place and the area computed in square yards (square meters). The width for measurement will be the top width of the bituminous surface treatment as shown on the plans or as directed by the Engineer.

Emulsified asphalt for fog seal will be measured for payment as specified in Section 1032.

Preparation of the base or existing surface will be measured for payment according to Article 358.06.

**403.17 Basis of Payment.** This work will be paid for at the contract unit price per square yard (square meter) for BITUMINOUS SURFACE TREATMENT, of the type specified.

Emulsified asphalt for fog seal will be paid for at the contract unit price per pound (kilogram) of residual asphalt for BITUMINOUS MATERIALS (FOG SEAL).

Preparation of the base or existing surface will be paid for according to Article 358.07.

When the contract does not contain a pay item for preparation of the base or existing surface and this item is required, it will be paid for according to Article 109.04.”

Replace Article 1004.03(c) of the Standard Specifications with the following:

“(c) Gradation. The coarse aggregate gradations shall be as listed in the following table.

Use	Size/Application	Gradation No.
Class A-1, A-2, & A-3	3/8 in. (10 mm) Seal	CA 16 or CA 20
Class A-2 & A-3	Cover Coat	CA 14 or CA 15
HMA High ESAL	IL-19.0	CA 11 <sup>1/</sup>
	SMA 12.5 <sup>2/</sup>	CA 13, CA 14, or CA 16 <sup>3/</sup>
	SMA 9.5 <sup>2/</sup>	CA 13, CA 14, or CA 16 <sup>3/</sup>
	IL-9.5	CA 16
	IL-9.5FG	CA 16
HMA Low ESAL	IL-19.0L	CA 11 <sup>1/</sup>
	IL-9.5L	CA 16

1/ CA 16 or CA 13 may be blended with CA 11.

2/ The coarse aggregates shall be capable of being combined with the fine aggregates and mineral filler to meet the approved mix design and the mix requirements noted herein.

3/ The specified coarse aggregate gradations may be blended.”

## WORK ZONE TRAFFIC CONTROL DEVICES (BDE)

Effective: March 2, 2020

Revised: January 1, 2026

Add the following to Article 701.03 of the Standard Specifications:

“(q) Temporary Sign Supports ..... 1106.02”

Revise Article 701.03(p) of the Standard Specifications to read:

“(p) Detectable Pedestrian Channelizing Barricades ..... 1106.02(m)”

Revise the third paragraph of Article 701.14 of the Standard Specifications to read:

“For temporary sign supports, the Contractor shall provide a FHWA eligibility letter for each device used on the contract. The letter shall provide information for the set-up and use of the device as well as a detailed drawing of the device. The signs shall be supported within 20 degrees of vertical. Weights used to stabilize signs shall be attached to the sign support per the manufacturer’s specifications.”

Revise the first paragraph of Article 701.15 of the Standard Specifications to read:

“**701.15 Traffic Control Devices.** For devices that must meet crashworthiness standards, the Contractor shall provide a manufacturer’s self-certification or a FHWA eligibility letter for each Category 1 device and a FHWA eligibility letter for each Category 2 and Category 3 device used on the contract. The self-certification or letter shall provide information for the set-up and use of the device as well as a detailed drawing of the device.”

Revise the first six paragraphs of Article 1106.02 of the Standard Specifications to read:

“**1106.02 Devices.** Work zone traffic control devices and combinations of devices shall meet crashworthiness standards for their respective categories. The categories are as follows.

Category 1 includes small, lightweight, channelizing and delineating devices that have been in common use for many years and are known to be crashworthy by crash testing of similar devices or years of demonstrable safe performance. These include cones, tubular markers, plastic drums, and delineators, with no attachments (e.g. lights). Category 1 devices shall be MASH compliant.

Category 2 includes devices that are not expected to produce significant vehicular velocity change but may otherwise be hazardous. These include vertical panels with lights, barricades, temporary sign supports, and Category 1 devices with attachments (e.g. drums with lights). Category 2 devices shall be MASH compliant.

Category 3 includes devices that are expected to cause significant velocity changes or other potentially harmful reactions to impacting vehicles. These include crash cushions (impact attenuators), truck mounted attenuators, and other devices not meeting the definitions of Category 1 or 2. Category 3 devices manufactured after December 31, 2019 shall be MASH compliant. Category 3 devices manufactured on or before December 31, 2019, and compliant with NCHRP 350, may be used on contracts let before December 31, 2029. Category 3 devices shall be crash tested for Test Level 3 or the test level specified.

Category 4 includes portable or trailer-mounted devices such as sign supports, speed feedback displays, arrow boards, changeable message signs, temporary traffic signals, and area lighting supports. It is preferable for Category 4 devices manufactured after December 31, 2019 to be MASH-16 compliant; however, there are currently no crash tested devices in this category, so it remains exempt from the NCHRP 350 or MASH compliance requirement.

For each type of device, when no more than one MASH compliant is available, an NCHRP 350 compliant device may be used, even if manufactured after December 31, 2019.”

Revise the first paragraph of Section 1106.02(a) of the Standard Specifications to read:

“(a) Lights. Lights shall meet the requirements of Chapter 13 of the “Equipment and Materials Standards of the Institute of Transportation Engineers,” 1998, Institute of Transportation Engineers, and shall be visible on a clear night from a distance of 3000 ft (900 m). Lights are classified as follows.”

Revise Articles 1106.02(g), 1106.02(k), 1106.02(l), and 1106.02(m) of the Standard Specifications to read:

“(g) Truck Mounted/Trailer Mounted Attenuators. The attenuator shall be approved for use at Test Level 3. Test Level 2 may be used for normal posted speeds less than or equal to 45 mph.

(k) Temporary Water Filled Barrier. The water filled barrier shall be a lightweight plastic shell designed to accept water ballast and be on the Department’s qualified product list.

Shop drawings shall be furnished by the manufacturer and shall indicate the deflection of the barrier as determined by acceptance testing; the configuration of the barrier in that test; and the vehicle weight, velocity, and angle of impact of the deflection test. The Engineer shall be provided one copy of the shop drawings.

(l) Movable Traffic Barrier. The movable traffic barrier shall be on the Department’s qualified product list.

Shop drawings shall be furnished by the manufacturer and shall indicate the deflection of the barrier as determined by acceptance testing; the configuration of the barrier in that test; and the vehicle weight, velocity, and angle of impact of the deflection test. The

Engineer shall be provided one copy of the shop drawings. The barrier shall be capable of being moved on and off the roadway on a daily basis.

- (m) Detectable Pedestrian Channelizing Barricades. The top panel or handrail shall be continuous and there should be at least a 2 in. (50 mm) gap between the hand trailing edge and its support. When visible to vehicular traffic, the top rail shall have alternating white and orange retroreflective stripes sloping at 45 degrees. The bottom panel shall be continuous and have alternating white and orange retroreflective stripes sloping at 45 degrees. Barricade stripes shall be 6 in. (150 mm) in width. The predominant color for other barricade components shall be white, orange, or silver.”

80427

## ULTRA-THIN BONDED WEARING COURSE (BDE)

Effective: April 1, 2020

Revised: January 1, 2022

Description. This work shall consist of constructing an ultra-thin bonded (UTB) wearing course on a prepared pavement.

Materials. Materials shall be according to the following.

Item	Article/Section
(a) Fine Aggregate .....	1003.03
(b) Coarse Aggregate (Note 1).....	1004.03
(c) Mineral Filler .....	1011
(d) Performance Graded Asphalt Binder (Note 2) .....	1032.05
(e) Bituminous Materials (Note 3) .....	1032

Note 1. The blending, alternate use, and/or substitutions of aggregates from different sources for use in this work will not be permitted without the approval of the Engineer. Any blending shall be by interlocked mechanical feeders. The blending shall be uniform, compatible with the other components of the mix, and the equipment shall be approved by the Engineer.

If blending aggregates, the blend shall have a washed gradation performed every other day or a minimum of three tests per week. Testing shall be completed before the aggregate receives final acceptance for use in the mix.

Note 2. The asphalt binder shall be either SBR or SBS PG 70-22.

Note 3. The bituminous material used for tack coat shall be a rapid setting anionic polymer modified emulsion or a rapid setting cationic polymer modified emulsion. When using a cationic material, the supplier shall certify prior to the start of mix production, the material has a positive particle charge when tested according to AASHTO T 59. When using either a cationic or anionic material, the supplier shall certify prior to the start of mix production, the material meets the following requirements.

Tests on Emulsions (AASHTO T 59)	Result
Viscosity, Saybolt Furol, 77 °F (25 °C), s	20 - 100
Viscosity, Rotational Paddle, 77 °F (25 °C), mPa-s (AASHTO T 382)	40 - 200
Storage Stability Test, 24 hours, % <sup>1/</sup>	1 max.
Sieve Test, % retained on #20 (850 µm) sieve	0.05 max.
Residue from Distillation, %	63 min.
Demulsibility:	
35 ml, 0.02N CaCl <sub>2</sub> , %, <u>or</u>	40 min.
35 ml, 0.8% dioctyl sodium sulfosuccinate, %	40 min.

Tests on Residue from Evaporation	Result
Penetration, 77 °F (25 °C), 100 g, 5 s, 0.1 mm, (AASHTO T 49)	90 - 150
Elastic Recovery, 50 °F (10 °C), straight sided, 5 cm/min, 20 cm elongation, 5 min hold, % (AASHTO T 301)	50 min.
Ash Content, % (AASHTO T 59)	1 max.

1/ Upon examination of the storage stability test cylinder after standing undisturbed for 24 hours, the surface shall show minimal to no white, milky colored substance and shall be a homogenous brown color throughout. The material may be released prior to completion of the test based on approval of the Department.

Equipment. Equipment shall be according to the following.

Item	Article/Section
(a) Tandem Rollers (Note 1) .....	1101.01
(b) Hot-Mix Asphalt Plant .....	1102.01
(c) Spreading and Finishing Machine (Note 2) .....	1102.03
(d) Heating Equipment .....	1102.07

Note 1. A minimum of two tandem rollers ( $T_B$ ), operating in the static mode, sufficient to match paving production will be required.

Note 2. The spreading and finishing machine shall be a “spray-paver” capable of spraying the tack coat, applying the wearing course, and providing a smooth surface to the mat in one pass at the rate of 30 ft/min (9 m/min) or greater. The wearing course shall be spread over the tack coat within five seconds of applying the tack coat during normal paving speeds. No wheel or other part of the spray-paver shall come in contact with the tack coat before the wearing course is applied. The spray-paver shall also have the following:

- (1) a receiving hopper with a minimum of two heated twin screw feed augers,
- (2) an integral storage tank for tack coat material,
- (3) integral twin expandable emulsion spray bars located immediately in front of the asphalt spread augers and an activated screed,
- (4) variable width vibratory heated activated screed. The screed shall have the ability to be crowned at the center both positively and negatively and have vertically adjustable extensions to accommodate the desired pavement profile.

### CONSTRUCTION REQUIREMENTS

Mixture Design. The target values for the Job Mix Formula (JMF) shall fall within the following limits.

ULTRA-THIN BONDED, MIXTURE COMPOSITION (% PASSING)		
Sieve Size	IL-12.5 UTB	IL-9.5 UTB
3/4 in. (19 mm)	100	--
1/2 in. (12.5 mm)	85 - 100	100
3/8 in. (9.5 mm)	55 - 80	85 - 100
No. 4 (4.75 mm)	22 - 38	22 - 38
No. 8 (2.36 mm)	19 - 32	19 - 32
No. 16 (1.18 mm)	15 - 24	15 - 24
No. 30 (600 µm)	11 - 18	11 - 18
No. 50 (300 µm)	8 - 14	8 - 14
No. 100 (150 µm)	5 - 10	5 - 10
No. 200 (75 µm)	4 - 5.5	4 - 5.5
Asphalt Binder, %	4.6 - 6.1	4.8 - 6.1

The need for an anti-stripping additive shall be determined according to Article 1030.05(c).

The effective binder film thickness shall be a minimum of  $0.3 \pm 0.03$  mils ( $10 \pm 1$  µm). The percent asphalt binder of the mix shall be determined by calculating the binder film thickness in accordance with Illinois Test Procedure (ITP) 406.

Draindown from the loose mixture shall not exceed 0.10 percent when tested according to Illinois Modified AASHTO T 305. The draindown shall be tested at the job mix formula asphalt content plus 0.5 percent. The temperature shall be the mixing temperature plus 59 °F (15 °C). The temperature shall not exceed 350 °F (175 °C).

The mixture shall not contain reclaimed materials.

The mixing temperature shall be according to Illinois Modified AASHTO T 312.

Preparation of Mineral Aggregates. The aggregates shall be heated in such a manner as to assure the mixing temperature is uniformly maintained. The aggregates shall be dried to less than 0.3 percent residual moisture by weight. This may require the aggregate to be processed twice through the drier.

Mix Production. After target values have been determined for the JMF, an adjustment/plant change may be made according to the following limitations.

Parameter	Adjustment
3/8 in. (9.5 mm)	± 5 %
No. 4 (4.75 mm)	± 5 %
No. 8 (2.36 mm)	± 5 %
No. 200 (75 µm)	± 1.5 %
Asphalt Binder Content <sup>1/</sup>	± 0.3 %

1/ The quantity of anti-stripping additive will not be included in this percentage.

Adjustments outside the above limitations will require a new mix design.

Placing. The placement conditions of Article 406.06(c) shall apply, except the surface of the existing pavement shall be cleaned using a mechanical or vacuum sweeper; and the mixture shall only be placed when the pavement and ambient air temperatures are at least 50 °F (10 °C) at the time of placement and the forecast is for rising temperatures.

The IL-12.5 UTB mixture shall be placed at a rate of 90 lb/sq yd (50 kg/sq m). The IL-9.5 UTB mixture shall be placed at a rate of 75 lb/sq yd (40 kg/sq m). These placement rates are based on a mixture with a unit weight of 100 lb/sq yd/in. (2.1 kg/sq m/mm) and a specific gravity of 2.5. Mixtures with a different specific gravity will require an adjusted placement rate to maintain the planned thickness.

The tack coat shall be uniformly spray applied with the spreading and finishing machine at a temperature of 120 - 180 °F (50 - 80 °C). The rate of application shall be accurately and continuously monitored to ensure a uniform application over the entire width to be overlaid. The rate of application shall be determined as follows.

- (a) Determination of In-Place Air Voids. Two 6 in. (150 mm) specimens shall be prepared according to AASHTO T 312 to 80 gyrations. The percent air voids shall be determined according to AASHTO T 269. The air void determination shall be the average of the two specimens. 2.5 percent air voids shall be added to the lab determined air voids to approximate in-place air voids.
- (b) Calculated Application Rate. Calculate the volume of 1 sq yd (1 sq m) of mix at a depth of 70 percent of the nominal maximum aggregate size. Multiply that volume by the percent of in-place air voids. Convert the volume to gal (L). Express the result in lb/sq ft (kg/sq m).

The Engineer will make field adjustments to the calculated application rate no greater than  $\pm 0.05$  lb/sq ft ( $\pm 0.25$  kg/sq m) based on the existing surface condition. Once the target application rate is established, the tolerance shall be  $\pm 0.01$  lb/sq ft ( $\pm 0.05$  kg/sq m).

Compaction. Compaction shall consist of each area of the mat receiving a minimum of two passes with a tandem roller, before the material temperature has fallen below 180 °F (80 °C).

Opening to Traffic. The wearing course may be opened to traffic when it has hardened to the satisfaction of the Engineer.

Quality Control/Quality Assurance. Material testing shall be according to Articles 1030.06 and 1030.09, except the following tests will not be required.

- (a) Bituminous Core Density
- (b) Nuclear Density

(c)  $G_{mm}$  and  $G_{mb}$  testing

Additionally, the Contractor shall have a representative present during construction that is familiar with the lay down of the product and its design methods.

Method of Measurement. The bituminous material for tack coat will be measured for payment as specified in Section 1032.

The wearing course will be measured for payment in place and the quantity computed in square yards (square meters).

Basis of Payment. The tack coat will be paid for at the contract unit price per pound (kilogram) of residual asphalt for RAPID SETTING POLYMER MODIFIED EMULSION.

The wearing course will be paid for at the contract unit price per square yard (square meter) for ULTRA-THIN BONDED WEARING COURSE, of the mixture composition and friction aggregate specified.

80429

**GREEN PREFORMED THERMOPLASTIC PAVEMENT MARKINGS (BDE)**

Effective: January 1, 2021

Revised: January 1, 2022

Revise the following in Table 1 of Article 780.15 of the Standard Specifications to read:

"SYMBOLS <sup>1/</sup>		
Symbol	Large Size sq ft (sq m)	Small Size sq ft (sq m)
Through Arrow	11.5 (1.07)	6.5 (0.60)
Left or Right Arrow	15.6 (1.47)	8.8 (0.82)
2 Arrow Combination Left (or Right) and Through	26.0 (2.42)	14.7 (1.37)
3 Arrow Combination Left, Right, and Through	38.4 (3.56)	20.9 (1.94)
Lane Drop Arrow	41.5 (3.86)	--
Wrong Way Arrow	24.3 (2.26)	--
Railroad "R" 6 ft (1.8 m)	3.6 (0.33)	--
Railroad "X" 20 ft (6.1 m)	54.0 (5.02)	--
International Symbol of Accessibility	3.1 (0.29)	--
Bike Symbol	4.7 (0.44)	--
Shared Lane Symbol	8.0 (0.74)	
Intersection Bicycle Box <sup>2/</sup>	variable sizes	
Two-Stage Bicycle Turn Box <sup>2/</sup>	variable sizes	

1/ Table applies to all types of pavement marking materials, except intersection bicycle box and two-stage bicycle turn box which are limited to preformed thermoplastic.

2/ The cost of symbols appearing in the box are included in the overall square area of the box."

Add the following paragraph to the end of Article 1095.01(a)(2) of the Standard Specifications:

"The pigments used for the green thermoplastic compound shall not contain any hazardous materials listed in the Environmental Protection Agency Code of Federal Regulations (CFR) 40, Section 261.24, Table 1. The combined total of RCRA listed heavy metals shall not exceed 100 ppm when tested by X-ray fluorescence spectroscopy. The pigments shall also be heat resistant, UV stable, and color-fast greens. The pigment shall be uniformly distributed throughout the thermoplastic compound."

Add the following to Article 1095.01(b)(1)e. of the Standard Specifications:

"Green **	Daylight Reflectance	15 % min.
-----------	----------------------	-----------

\*\* Shall meet the coordinates of the following color tolerance chart.

x	0.230	0.266	0.367	0.444
y	0.754	0.460	0.480	0.583"

80433

## **SURFACE TESTING OF PAVEMENTS – IRI (BDE)**

Effective: January 1, 2021

Revised: January 1, 2023

Description. This work shall consist of testing the ride quality of the finished surface of pavement sections with new concrete pavement, PCC overlays, full-depth HMA, and HMA overlays with at least 2.25 in. (57 mm) total thickness of new HMA combined with either HMA binder or HMA surface removal, according to Illinois Test Procedure 701, "Ride Quality Testing Using the International Roughness Index (IRI)". Work shall be according to Sections 406, 407, or 420 of the Standard Specifications, except as modified herein.

### **Hot-Mix Asphalt (HMA) Overlays**

Add the following to Article 406.03 of the Standard Specifications:

"(n) Pavement Surface Grinding Equipment..... 1101.04"

Revise Article 406.11 of the Standard Specifications to read:

**"406.11 Surface Tests.** Prior to HMA overlay pavement improvements, the Engineer will measure the smoothness of the existing high-speed mainline pavement. The Contractor shall measure the smoothness of the finished high-speed mainline, low-speed mainline, and miscellaneous pavements after the pavement improvement is complete but within the same construction season. Testing shall be performed in the presence of the Engineer and according to Illinois Test Procedure 701. The pavement will be identified as high-speed mainline, low-speed mainline, or miscellaneous as follows.

(a) Test Sections.

- (1) High-Speed Mainline Pavement. High-speed mainline pavement consists of pavements, ramps, and loops with a posted speed limit greater than 45 mph. These sections shall be tested with an inertial profiling system (IPS).
- (2) Low-Speed Mainline Pavement. Low-speed mainline pavement consists of pavements, ramps, and loops with a posted speed limit of 45 mph or less. These sections shall be tested using a 16 ft (5 m) straightedge or with an IPS analyzed using the rolling 16 ft (5 m) straightedge simulation in ProVAL.
- (3) Miscellaneous Pavement. Miscellaneous pavement are segments that either cannot readily be tested by an IPS or conditions beyond the control of the Contractor preclude the achievement of smoothness levels typically achievable with mainline pavement construction. This may include the following examples or as determined by the Engineer.

- a. Pavement on horizontal curves with a centerline radius of curvature of less than or equal to 1,000 ft (300 m) and the pavement within the superelevation transition of such curves;
- b. Pavement on vertical curves having a length less than or equal to 200 ft (60 m) in combination with an algebraic change in tangent grade greater than or equal to 3 percent as may occur on urban ramps or other constricted-space facilities;
- c. The first and last 50 ft (15 m) of a pavement section where the Contractor is not responsible for the adjoining surface;
- d. Intersections and the 25 ft (7.6 m) before and after an intersection or end of radius return;
- e. Variable width pavements;
- f. Side street returns, to the end of radius return;
- g. Crossovers;
- h. Pavement connector for bridge approach slab;
- i. Bridge approach slab;
- j. Pavement that must be constructed in segments of 600 ft (180 m) or less;
- k. Pavement within 25 ft (7.6 m) of manholes, utility structures, at-grade railroad crossings, or other appurtenances;
- l. Turn lanes; and
- m. Pavement within 5 ft (1.5 m) of jobsite sampling locations for HMA volumetric testing that fall within the wheel path.

Miscellaneous pavement shall be tested using a 16 ft (5 m) straightedge.

- (4) International Roughness Index (IRI). An index computed from a longitudinal profile measurement using a quarter-car simulation at a simulation speed of 50 mph (80 km/h).
- (5) Mean Roughness Index (MRI). The average of the IRI values for the right and left wheel tracks.
  - a.  $MRI_0$ . The MRI of the existing pavement prior to construction.
  - b.  $MRI_i$ . The MRI value that warrants an incentive payment.

- c.  $MRI_F$ . The MRI value that warrants full payment.
  - d.  $MRI_D$ . The MRI value that warrants a financial disincentive.
- (6) Areas of Localized Roughness (ALR). Isolated areas of roughness, which can cause significant increase in the calculated MRI for a given subplot.
- (7) Subplot. A continuous strip of pavement 0.1 mile (160 m) long and one lane wide. A partial subplot greater than or equal to 264 ft (80 m) will be subject to the same evaluation as a whole subplot. Partial subplots less than 264 ft (80 m) shall be included with the previous subplot for evaluation purposes.
- (b) Corrective Work. Corrective work shall be completed according to the following.
- (1) High-Speed Mainline Pavement. For high-speed mainline pavement, any 25 ft (7.6 m) interval with an ALR in excess of 200 in./mile (3,200 mm/km) will be identified by the Engineer and shall be corrected by the Contractor. Any subplot having a MRI greater than  $MRI_D$ , including ALR, shall be corrected to reduce the MRI to the  $MRI_F$ , or replaced at the Contractor's option.
  - (2) Low-Speed Mainline Pavement. Surface variations in low-speed mainline pavement which exceed the 5/16 in. (8 mm) tolerance will be identified by the Engineer and shall be corrected by the Contractor.
  - (3) Miscellaneous Pavements. Surface variations in miscellaneous pavement which exceed the 5/16 in. (8 mm) tolerance will be identified by the Engineer and shall be corrected by the Contractor.

Corrective work shall be completed with pavement surface grinding equipment or by removing and replacing the pavement. Corrective work shall be applied to the full lane width. When completed, the corrected area shall have uniform texture and appearance, with the beginning and ending of the corrected area perpendicular to the centerline of the paved surface.

Upon completion of the corrective work, the surface of the subplot(s) shall be retested. The Contractor shall furnish the data and reports to the Engineer within 2 working days after corrections are made. If the MRI and/or ALR still do not meet the requirements, additional corrective work shall be performed.

Corrective work shall be at no additional cost to the Department.

- (c) Smoothness Assessments. Assessments will be paid to or deducted from the Contractor for each subplot of high-speed mainline pavement per the Smoothness Assessment Schedule. Assessments will be based on the MRI of each subplot prior to performing any corrective work unless the Contractor has chosen to remove and replace the pavement.

For pavement that is replaced, assessments will be based on the MRI determined after replacement.

The upper MRI thresholds for high-speed mainline pavement are dependent on the MRI of the existing pavement before construction ( $MRI_0$ ) and shall be determined as follows.

Upper MRI Thresholds <sup>1/</sup>	MRI Thresholds (High-Speed, HMA Overlay)	
	$MRI_0 \leq 125.0$ in./mile ( $\leq 1,975$ mm/km)	$MRI_0 > 125.0$ in./mile <sup>1/</sup> ( $> 1,975$ mm/km)
Incentive ( $MRI_I$ )	45.0 in./mile (710 mm/km)	$0.2 \times MRI_0 + 20$
Full Pay ( $MRI_F$ )	75.0 in./mile (1,190 mm/km)	$0.2 \times MRI_0 + 50$
Disincentive ( $MRI_D$ )	100.0 in./mile (1,975 mm/km)	$0.2 \times MRI_0 + 75$

1/  $MRI_0$ ,  $MRI_I$ ,  $MRI_F$ , and  $MRI_D$  shall be in in./mile for calculation.

Smoothness assessments for high-speed mainline pavement shall be determined as follows.

SMOOTHNESS ASSESSMENT SCHEDULE (High-Speed, HMA Overlay)	
Mainline Pavement MRI Range	Assessment Per Sublot <sup>1/</sup>
$MRI \leq MRI_I$	$+ (MRI_I - MRI) \times \$20.00$ <sup>2/</sup>
$MRI_I < MRI \leq MRI_F$	$+ \$0.00$
$MRI_F < MRI \leq MRI_D$	$- (MRI - MRI_F) \times \$8.00$
$MRI > MRI_D$	$- \$200.00$

1/  $MRI$ ,  $MRI_I$ ,  $MRI_F$ , and  $MRI_D$  shall be in in./mile for calculation.

2/ The maximum incentive amount shall not exceed \$300.00.

Smoothness assessments will not be paid or deducted until all other contract requirements for the pavement are satisfied. Pavement that is corrected or replaced for reasons other than smoothness, shall be retested as stated herein.”

### **Hot-Mix Asphalt (HMA) Pavement (Full-Depth)**

Revise the first paragraph of Article 407.03 of the Standard Specifications to read:

**“407.03 Equipment.** Equipment shall be according to Article 406.03.”

Revise Article 407.09 of the Standard Specifications to read:

**“407.09 Surface Tests.** The finished surface of the pavement shall be tested for smoothness

according to Article 406.11, except as follows:

The testing of the existing pavement prior to improvements shall not apply and the smoothness assessment for high-speed mainline pavement shall be determined according to the following table.

SMOOTHNESS ASSESSMENT SCHEDULE (High-Speed, Full-Depth HMA)	
Mainline Pavement MRI, in./mile (mm/km)	Assessment Per Sublot <sup>1/</sup>
≤ 45.0 (710)	+ (45 – MRI) × \$45.00 <sup>2/</sup>
> 45.0 (710) to 75.0 (1,190)	+ \$0.00
> 75.0 (1,190) to 100.0 (1,580)	– (MRI – 75) × \$20.00
> 100.0 (1,580)	– \$500.00

1/ MRI shall be in in./mile for calculation.

2/ The maximum incentive amount shall not exceed \$800.00.”

### **Portland Cement Concrete Pavement**

Delete Article 420.03(i) of the Standard Specifications.

Revise Article 420.10 of the Standard Specifications to read:

**“420.10 Surface Tests.** The finished surface of the pavement shall be tested for smoothness according to Article 406.11, except as follows.

The testing of the existing pavement prior to improvements shall not apply. The Contractor shall measure the smoothness of the finished surface of the pavement after the pavement has attained a flexural strength of 250 psi (3,800 kPa) or a compressive strength of 1,600 psi (20,700 kPa).

Membrane curing damaged during testing shall be repaired as directed by the Engineer at no additional cost to the Department.

(a) Corrective Work. No further texturing for skid resistance will be required for areas corrected by grinding. Protective coat shall be reapplied to areas ground according to Article 420.18 at no additional cost to the Department.

Jointed portland cement concrete pavement corrected by removal and replacement, shall be corrected in full panel sizes.

(b) Smoothness Assessments. Smoothness assessment for high-speed mainline pavement shall be determined as follows.

SMOOTHNESS ASSESSMENT SCHEDULE (High-Speed, PCC)	
Mainline Pavement MRI, in./mile (mm/km) <sup>3/</sup>	Assessment Per Sublot <sup>1/</sup>
≤ 45.0 (710)	+ (45 – MRI) × \$60.00 <sup>2/</sup>
> 45.0 (710) to 75.0 (1,190)	+ \$0.00
> 75.0 (1,190) to 100.0 (1,580)	– (MRI – 75) × \$37.50
> 100.0 (1,580)	– \$750.00

1/ MRI shall be in in./mile for calculation.

2/ The maximum incentive amount shall not exceed \$1200.00.

3/ If pavement is constructed with traffic in the lane next to it, then an additional 10 in./mile will be added to the upper thresholds.”

### **Removal of Existing Pavement and Appurtenances**

Revise the first paragraph of Article 440.04 of the Standard Specifications to read:

“**440.04 HMA Surface Removal for Subsequent Resurfacing.** The existing HMA surface shall be removed to the depth specified on the plans with a self-propelled milling machine. The removal depth may be varied slightly at the discretion of the Engineer to satisfy the smoothness requirements of the finished pavement. The temperature at which the work is performed, the nature and condition of the equipment, and the manner of performing the work shall be such that the milled surface is not torn, gouged, shoved or otherwise damaged by the milling operation. Sufficient cutting passes shall be made so that all irregularities or high spots are eliminated to the satisfaction of the Engineer. When tested with a 16 ft (5 m) straightedge, the milled surface shall have no surface variations in excess of 3/16 in. (5 mm).”

### **General Equipment**

Revise Article 1101.04 of the Standard Specifications to read:

“**1101.04 Pavement Surface Grinding Equipment.** The pavement surface grinding device shall have a minimum effective head width of 3 ft (0.9 m).

- (a) Diamond Saw Blade Machine. The machine shall be self-propelled with multiple diamond saw blades.
- (b) Profile Milling Machine. The profile milling machine shall be a drum device with carbide or diamond teeth with spacing of 0.315 in. (8 mm) or less and maintain proper forward speed for surface texture according to the manufacturer’s specifications.”

## **SUBMISSION OF PAYROLL RECORDS – STATE CONTRACT (BDE)**

Effective: April 1, 2021

Revised: April 1, 2026

Revise Item 3 of Section IV of Check Sheet #5 of the Recurring Special Provisions to read:

- “3. Submission of Payroll Records. The Contractor and each subcontractor shall, no later than the 15<sup>th</sup> day of each calendar month, file a certified payroll for the immediately preceding month to the Illinois Department of Labor (IDOL) through the Certified Transcript of Payroll Portal in compliance with the State Prevailing Wage Act (820 ILCS 130). The portal can be found on the IDOL website at <https://labor.illinois.gov>. Payrolls shall be submitted in the format prescribed by the IDOL.

In addition to filing certified payroll(s) with the IDOL, the Contractor and each subcontractor shall certify and submit payroll records to the Department each week from the start to the completion of their respective work, except that full social security numbers shall not be included on weekly submittals. Instead, the payrolls shall include an identification number for each employee (e.g., the last four digits of the employee’s social security number). In addition, starting and ending times of work each day may be omitted from the payroll records submitted. The submittals shall be made using LCPtracker Pro software. The software is web-based and can be accessed at <https://lcptracker.com/>. When there has been no activity during a work week, a payroll record shall still be submitted with the appropriate option (“No Work”, “Suspended”, or “Complete”) selected.”

## **ILLINOIS WORKS APPRENTICESHIP INITIATIVE – STATE FUNDED CONTRACTS (BDE)**

Effective: June 2, 2021

Revised: April 2, 2024

Illinois Works Jobs Program Act (30 ILCS 559/20-1 et seq.). For contracts having an awarded contract value of \$500,000 or more, the Contractor shall comply with the Illinois Works Apprenticeship Initiative (30 ILCS 559/20-20 to 20-25) and all applicable administrative rules. The goal of the Illinois Apprenticeship Works Initiative is that apprentices will perform either 10% of the total labor hours actually worked in each prevailing wage classification or 10% of the estimated labor hours in each prevailing wage classification, whichever is less. Of this goal, at least 50% of the labor hours of each prevailing wage classification performed by apprentices shall be performed by graduates of the Illinois Works Pre-Apprenticeship Program, the Illinois Climate Works Pre-Apprenticeship Program, or the Highway Construction Careers Training Program.

The Contractor may seek from the Department of Commerce and Economic Opportunity (DCEO) a waiver or reduction of this goal in certain circumstances pursuant to 30 ILCS 559/20-20(b). The Contractor shall ensure compliance during the term of the contract and will be required to report on and certify its compliance. An apprentice use plan, apprentice hours, and a compliance certification shall be submitted to the Engineer on forms provided by the Department and/or DCEO.

80438

## **VEHICLE AND EQUIPMENT WARNING LIGHTS (BDE)**

Effective: November 1, 2021

Revised: November 1, 2022

Add the following paragraph after the first paragraph of Article 701.08 of the Standard Specifications:

“The Contractor shall equip all vehicles and equipment with high-intensity oscillating, rotating, or flashing, amber or amber-and-white, warning lights which are visible from all directions. In accordance with 625 ILCS 5/12-215, the lights may only be in operation while the vehicle or equipment is engaged in construction operations.”

80439

## PERFORMANCE GRADED ASPHALT BINDER (BDE)

Effective: January 1, 2023

Revised: April 1, 2026

Revise Article 1032.05 of the Standard Specifications to read:

**“1032.05 Performance Graded Asphalt Binder.** These materials will be accepted according to the Bureau of Materials Policy Memorandum, “Performance Graded Asphalt Binder Qualification Procedure.” The Department will maintain a qualified producer list. These materials shall be free from water and shall not foam when heated to any temperature below the actual flash point. Air blown asphalt, recycle engine oil bottoms (ReOB), and polyphosphoric acid (PPA) modification shall not be used.

When requested, producers shall provide the Engineer with viscosity/temperature relationships for the performance graded asphalt binders delivered and incorporated in the work.

- (a) Performance Graded (PG) Asphalt Binder. The asphalt binder shall meet the requirements of AASHTO M 320, Table 1 “Standard Specification for Performance Graded Asphalt Binder” for the grade shown on the plans and the following.

Test	Parameter
Small Strain Parameter (AASHTO PP 113) BBR, $\Delta T_c$ , 40 hrs PAV (40 hrs continuous or 2 PAV at 20 hrs)	-5 °C min.

- (b) Modified Performance Graded (PG) Asphalt Binder. The asphalt binder shall meet the requirements of AASHTO M 320, Table 1 “Standard Specification for Performance Graded Asphalt Binder” for the grade shown on the plans.

Asphalt binder modification shall be performed at the source, as defined in the Bureau of Materials Policy Memorandum, “Performance Graded Asphalt Binder Qualification Procedure.”

Modified asphalt binder shall be safe to handle at asphalt binder production and storage temperatures or HMA construction temperatures. Safety Data Sheets (SDS) shall be provided for all asphalt modifiers.

- (1) Polymer Modification (SBS). Elastomers shall be added to the base asphalt binder to achieve the specified performance grade and shall be a styrene-butadiene-styrene without oil extension. The polymer modified asphalt binder shall be smooth, homogeneous, and be according to the following requirements for the grade shown on the plans.

Requirements for Styrene-Butadiene Copolymer (SBS) Modified Asphalt Binders			
Separation of Polymer ITP, "Separation of Polymer from Asphalt Binder" Difference in °F (°C) of the softening point between top and bottom portions		4 (2) max.	
Tests on Residue from Rolling Thin Film Oven Test (RTFO), AASHTO T 240			
Multiple Stress Creep Recovery (MSCR), AASHTO T 350			
Asphalt Grade	Test Temperature	Maximum J <sub>nr</sub> (3.2 kPa)	Minimum % Recovery (3.2 kPa)
SBS 76-22	64 °C	≤ 0.5	≥ 75 %
SBS 70-22		≤ 2	≥ 30 %
SBS 76-28	58 °C	≤ 0.5	≥ 80 %
SBS 70-28		≤ 1	≥ 60 %
SBS 64-28		≤ 2	≥ 30 %

- (2) Ground Tire Rubber (GTR) Modification. GTR modification is the addition of recycled ground tire rubber to liquid asphalt binder to achieve the specified performance grade. GTR shall be produced from processing automobile and/or truck tires by the ambient grinding method or micronizing through a cryogenic process. GTR shall not exceed 1/16 in. (2 mm) in any dimension and shall not contain free metal particles, moisture that would cause foaming of the asphalt, or other foreign materials. A mineral powder (such as talc) meeting the requirements of AASHTO M 17 may be added, up to a maximum of four percent by weight of GTR to reduce sticking and caking of the GTR particles. When tested in accordance with Illinois Modified AASHTO T 27 "Standard Method of Test for Sieve Analysis of Fine and Coarse Aggregates" or AASHTO PP 74 "Standard Practice for Determination of Size and Shape of Glass Beads Used in Traffic Markings by Means of Computerized Optical Method", a 50 g sample of the GTR shall conform to the following gradation requirements.

Sieve Size	Percent Passing
No. 16 (1.18 mm)	100
No. 30 (600 µm)	95 ± 5
No. 50 (300 µm)	> 20

GTR modified asphalt binder shall be tested for rotational viscosity according to AASHTO T 316 using spindle S27. GTR modified asphalt binder shall be tested for original dynamic shear and RTFO dynamic shear according to AASHTO T 315 using a gap of 2 mm.

Requirements for Ground Tire Rubber (GTR) Modified Asphalt Binders		
TESTS ON RESIDUE FROM ROLLING THIN FILM OVEN TEST (AASHTO T 240)		
Elastic Recovery ASTM D 6084, Procedure A, 77 °F (25 °C), 100 mm elongation, %	60 min.	70 min.

- (3) Softener Modification (SM). Softener modification is the addition of organic compounds, such as engineered flux, bio-oil blends, modified vegetable oils, amines, and fatty acid derivatives, to the base asphalt binder to achieve the specified performance grade. Softeners shall be dissolved, dispersed, or reacted in the asphalt binder to enhance its performance and shall remain compatible with the asphalt binder with no separation. Softeners shall not be added to modified PG asphalt binder as defined in Article 1032.05(b)(2).

An Attenuated Total Reflectance-Fourier Transform Infrared spectrum (ATR-FTIR) shall be collected for both the softening compound as well as the softener modified asphalt binder at the dose intended for qualification. The ATR-FTIR spectra shall be collected on unaged softener modified binder, 20-hour Pressurized Aging Vessel (PAV) aged softener modified binder, and 40-hour PAV aged softener modified binder. The ATR-FTIR shall be collected in accordance with Illinois Test Procedure 601. The electronic files spectral files (in one of the following extensions or equivalent: \*.SPA, \*.SPG, \*.IRD, \*.IFG, \*.CSV, \*.SP, \*.IRS, \*.GAML, \*. [0-9], \*.IGM, \*.ABS, \*.DRT, \*.SBM, \*.RAS) shall be submitted to the Central Bureau of Materials.

Requirements for Softener Modified (SM) Asphalt Binders		
Test	Asphalt Grade	
		SM PG 46-28
	SM PG 52-28	SM PG 52-34
	SM PG 58-22	SM PG 58-28
	SM PG 64-22	
Small Strain Parameter (AASHTO PP 113) BBR, $\Delta T_c$ , 40 hrs PAV (40 hrs continuous or 2 PAV at 20 hrs)	-5 °C min.	
Large Strain Parameter (Illinois Modified AASHTO T 391) DSR/LAS Fatigue Property, $\Delta G^* _{peak}$ , 40 hrs PAV (40 hrs continuous or 2 PAV at 20 hrs)	$\geq 54$ %	

- (4) Polymer/Softener Modification (SBS/SM). Polymer/Softener modification is the addition of organic compounds, such as engineered flux, bio-oil blends, modified vegetable oils, amines, and fatty acid derivatives, used in combination with SBS modified PG asphalt binder as modified in accordance with Article 1032.05(b)(1) to achieve the specified performance grade. Polymer/Softeners shall be compatible with

each other and dissolved, dispersed, or reacted in the asphalt binder to enhance its performance and shall remain compatible with the asphalt binder with no separation. Polymer/Softeners shall not be added to modified PG asphalt binder as defined in Article 1032.05(b)(2).

An Attenuated Total Reflectance-Fourier Transform Infrared spectrum (ATR-FTIR) shall be collected for both the polymer and the softening compound as well as the polymer/softener modified asphalt binder at the dose intended for qualification. The ATR-FTIR spectra shall be collected on unaged polymer/softener modified binder, 20-hour Pressurized Aging Vessel (PAV) aged polymer/softener modified binder, and 40-hour PAV aged polymer/softener modified binder. The ATR-FTIR shall be collected in accordance with Illinois Test Procedure 601. The electronic files spectral files (in one of the following extensions or equivalent: \*.SPA, \*.SPG, \*.IRD, \*.IFG, \*.CSV, \*.SP, \*.IRS, \*.GAML, \*.[0-9], \*.IGM, \*.ABS, \*.DRT, \*.SBM, \*.RAS) shall be submitted to the Central Bureau of Materials.

Requirements for Polymer/Softener Modified (SBS-SM) Asphalt Binders			
Separation of Polymer ITP, "Separation of Polymer from Asphalt Binder" Difference in °F (°C) of the softening point between top and bottom portions		4 (2) max.	
Tests on Residue from Rolling Thin Film Oven Test (RTFO), AASHTO T 240			
Multiple Stress Creep Recovery (MSCR), AASHTO T 350			
Asphalt Grade	Test Temperature	Maximum $J_{nr}$ (3.2 kPa)	Minimum % Recovery (3.2 kPa)
SBS-SM 76-22	64 °C	≤ 0.5	≥ 75 %
SBS-SM 70-22		≤ 2	≥ 30 %
SBS-SM 76-28	58 °C	≤ 0.5	≥ 80 %
SBS-SM 70-28		≤ 1	≥ 60 %
SBS-SM 64-28		≤ 2	≥ 30 %
Small Strain Parameter (AASHTO PP 113) BBR, $\Delta T_c$ , 40 hrs PAV (40 hrs continuous or 2 PAV at 20 hrs)			-5 °C min.
Large Strain Parameter (Illinois Modified AASHTO T 391) DSR/LAS Fatigue Property, $\Delta G^* _{peak}$ $\tau$ , 40 hrs PAV (40 hrs continuous or 2 PAV at 20 hrs)			≥ 60 %

The following grades may be specified as tack coats.

Asphalt Grade	Use
PG 58-22, PG 58-28, PG 64-22	Tack Coat"

Revise Article 1031.06(c)(1) and 1031.06(c)(2) of the Standard Specifications to read:

“(1) RAP/RAS. When RAP is used alone or RAP is used in conjunction with RAS, the percentage of virgin ABR shall not exceed the amounts listed in the following table.

HMA Mixtures - RAP/RAS Maximum ABR % <sup>1/ 2/</sup>			
Ndesign	Binder	Surface	Polymer Modified Binder or Surface <sup>3/</sup>
30	30	30	10
50	25	15	10
70	15	10	10
90	10	10	10

1/ For Low ESAL HMA shoulder and stabilized subbase, the RAP/RAS ABR shall not exceed 50 percent of the mixture.

2/ When RAP/RAS ABR exceeds 20 percent, the high and low virgin asphalt binder grades shall each be reduced by one grade (i.e. 25 percent ABR would require a virgin asphalt binder grade of PG 64-22 to be reduced to a PG 58-28).

3/ The maximum ABR percentages for ground tire rubber (GTR) modified mixes shall be equivalent to the percentages specified for SBS polymer modified mixes.

(2) FRAP/RAS. When FRAP is used alone or FRAP is used in conjunction with RAS, the percentage of virgin asphalt binder replacement shall not exceed the amounts listed in the following table.

HMA Mixtures - FRAP/RAS Maximum ABR % <sup>1/ 2/</sup>			
Ndesign	Binder	Surface	Polymer Modified Binder or Surface <sup>3/</sup>
30	55	45	15
50	45	40	15
70	45	35	15
90	45	35	15
SMA	--	--	25
IL-4.75	--	--	35

1/ For Low ESAL HMA shoulder and stabilized subbase, the FRAP/RAS ABR shall not exceed 50 percent of the mixture.

2/ When FRAP/RAS ABR exceeds 20 percent for all mixes, the high and low virgin asphalt binder grades shall each be reduced by one grade (i.e. 25 percent ABR would require a virgin asphalt binder grade of PG 64-22 to be reduced to a PG 58-28).

- 3/ The maximum ABR percentages for GTR modified mixes shall be equivalent to the percentages specified for SBS polymer modified mixes.”

Add the following to the end of Note 2 of Article 1030.03 of the Standard Specifications.

“A dedicated storage tank for the ground tire rubber (GTR) modified asphalt binder shall be provided. This tank shall be capable of providing continuous mechanical mixing throughout and/or recirculation of the asphalt binder to provide a uniform mixture. The tank shall be heated and capable of maintaining the temperature of the asphalt binder at 300 °F to 350 °F (149 °C to 177 °C). The asphalt binder metering systems of dryer drum plants shall be calibrated with the actual GTR modified asphalt binder material with an accuracy of  $\pm 0.40$  percent.”

80441

## **SEEDING (BDE)**

Effective: November 1, 2022

Revise Article 250.07 of the Standard Specifications to read:

**“250.07 Seeding Mixtures.** The classes of seeding mixtures and combinations of mixtures will be designated in the plans.

When an area is to be seeded with two or more seeding classes, those mixtures shall be applied separately on the designated area within a seven day period. Seeding shall occur prior to placement of mulch cover. A Class 7 mixture can be applied at any time prior to applying any seeding class or added to them and applied at the same time.

TABLE 1 - SEEDING MIXTURES

Class - Type	Seeds	lb/acre (kg/hectare)
1 Lawn Mixture 1/	Kentucky Bluegrass Perennial Ryegrass <i>Festuca rubra</i> ssp. <i>rubra</i> (Creeping Red Fescue)	100 (110) 60 (70) 40 (50)
1A Salt Tolerant Lawn Mixture 1/	Kentucky Bluegrass Perennial Ryegrass <i>Festuca rubra</i> ssp. <i>rubra</i> (Creeping Red Fescue) <i>Festuca brevipilla</i> (Hard Fescue) <i>Puccinellia distans</i> (Fulfs Saltgrass or Salty Alkaligrass)	60 (70) 20 (20) 20 (20) 20 (20) 60 (70)
1B Low Maintenance Lawn Mixture 1/	Turf-Type Fine Fescue 3/ Perennial Ryegrass Red Top <i>Festuca rubra</i> ssp. <i>rubra</i> (Creeping Red Fescue)	150 (170) 20 (20) 10 (10) 20 (20)
2 Roadside Mixture 1/	<i>Lolium arundinaceum</i> (Tall Fescue) Perennial Ryegrass <i>Festuca rubra</i> ssp. <i>rubra</i> (Creeping Red Fescue) Red Top	100 (110) 50 (55) 40 (50) 10 (10)
2A Salt Tolerant Roadside Mixture 1/	<i>Lolium arundinaceum</i> (Tall Fescue) Perennial Ryegrass <i>Festuca rubra</i> ssp. <i>rubra</i> (Creeping Red Fescue) <i>Festuca brevipilla</i> (Hard Fescue) <i>Puccinellia distans</i> (Fulfs Saltgrass or Salty Alkaligrass)	60 (70) 20 (20) 30 (20) 30 (20) 60 (70)
3 Northern Illinois Slope Mixture 1/	<i>Elymus canadensis</i> (Canada Wild Rye) 5/ Perennial Ryegrass Alsike Clover 4/ <i>Desmanthus illinoensis</i> (Illinois Bundleflower) 4/ 5/ <i>Schizachyrium scoparium</i> (Little Bluestem) 5/ <i>Bouteloua curtipendula</i> (Side-Oats Grama) 5/ <i>Puccinellia distans</i> (Fulfs Saltgrass or Salty Alkaligrass) Oats, Spring Slender Wheat Grass 5/ Buffalo Grass 5/ 7/	5 (5)  20 (20) 5 (5) 2 (2)  12 (12)  10 (10)  30 (35) 50 (55) 15 (15) 5 (5)
3A Southern Illinois Slope Mixture 1/	Perennial Ryegrass <i>Elymus canadensis</i> (Canada Wild Rye) 5/ <i>Panicum virgatum</i> (Switchgrass) 5/ <i>Schizachyrium scoparium</i> (Little Blue Stem) 5/ <i>Bouteloua curtipendula</i> (Side-Oats Grama) 5/ <i>Dalea candida</i> (White Prairie Clover) 4/ 5/ <i>Rudbeckia hirta</i> (Black-Eyed Susan) 5/ Oats, Spring	20 (20) 20 (20)  10 (10) 12 (12)  10 (10)  5 (5)  5 (5) 50 (55)

Class – Type	Seeds	lb/acre (kg/hectare)
4 Native Grass 2/ 6/	<i>Andropogon gerardi</i> (Big Blue Stem) 5/	4 (4)
	<i>Schizachyrium scoparium</i> (Little Blue Stem) 5/	5 (5)
	<i>Bouteloua curtipendula</i> (Side-Oats Grama) 5/	5 (5)
	<i>Elymus canadensis</i> (Canada Wild Rye) 5/	1 (1)
	<i>Panicum virgatum</i> (Switch Grass) 5/	1 (1)
	<i>Sorghastrum nutans</i> (Indian Grass) 5/	2 (2)
	Annual Ryegrass	25 (25)
	Oats, Spring	25 (25)
	Perennial Ryegrass	15 (15)
	4A Low Profile Native Grass 2/ 6/	<i>Schizachyrium scoparium</i> (Little Blue Stem) 5/
<i>Bouteloua curtipendula</i> (Side-Oats Grama) 5/		5 (5)
<i>Elymus canadensis</i> (Canada Wild Rye) 5/		1 (1)
<i>Sporobolus heterolepis</i> (Prairie Dropseed) 5/		0.5 (0.5)
Annual Ryegrass		25 (25)
Oats, Spring		25 (25)
Perennial Ryegrass		15 (15)
4B Wetland Grass and Sedge Mixture 2/ 6/	Annual Ryegrass	25 (25)
	Oats, Spring	25 (25)
	Wetland Grasses (species below) 5/	6 (6)
<u>Species:</u>		<u>% By Weight</u>
<i>Calamagrostis canadensis</i> (Blue Joint Grass)		12
<i>Carex lacustris</i> (Lake-Bank Sedge)		6
<i>Carex slipata</i> (Awl-Fruited Sedge)		6
<i>Carex stricta</i> (Tussock Sedge)		6
<i>Carex vulpinoidea</i> (Fox Sedge)		6
<i>Eleocharis acicularis</i> (Needle Spike Rush)		3
<i>Eleocharis obtusa</i> (Blunt Spike Rush)		3
<i>Glyceria striata</i> (Fowl Manna Grass)		14
<i>Juncus effusus</i> (Common Rush)		6
<i>Juncus tenuis</i> (Slender Rush)		6
<i>Juncus torreyi</i> (Torrey's Rush)		6
<i>Leersia oryzoides</i> (Rice Cut Grass)		10
<i>Scirpus acutus</i> (Hard-Stemmed Bulrush)		3
<i>Scirpus atrovirens</i> (Dark Green Rush)		3
<i>Bolboschoenus fluviatilis</i> (River Bulrush)		3
<i>Schoenoplectus tabernaemontani</i> (Softstem Bulrush)		3
<i>Spartina pectinata</i> (Cord Grass)		4

Class – Type	Seeds	lb/acre (kg/hectare)	
5	Forb with Annuals Mixture 2/ 5/ 6/	Annuals Mixture (Below) Forb Mixture (Below)	1 (1) 10 (10)
Annuals Mixture - Mixture not exceeding 25 % by weight of any one species, of the following:			
<i>Coreopsis lanceolata</i> (Sand Coreopsis) <i>Leucanthemum maximum</i> (Shasta Daisy) <i>Gaillardia pulchella</i> (Blanket Flower) <i>Ratibida columnifera</i> (Prairie Coneflower) <i>Rudbeckia hirta</i> (Black-Eyed Susan)			
Forb Mixture - Mixture not exceeding 5 % by weight PLS of any one species, of the following:			
<i>Amorpha canescens</i> (Lead Plant) 4/ <i>Anemone cylindrica</i> (Thimble Weed) <i>Asclepias tuberosa</i> (Butterfly Weed) <i>Aster azureus</i> (Sky Blue Aster) <i>Symphotrichum leave</i> (Smooth Aster) <i>Aster novae-angliae</i> (New England Aster) <i>Baptisia leucantha</i> (White Wild Indigo) 4/ <i>Coreopsis palmata</i> (Prairie Coreopsis) <i>Echinacea pallida</i> (Pale Purple Coneflower) <i>Eryngium yuccifolium</i> (Rattlesnake Master) <i>Helianthus mollis</i> (Downy Sunflower) <i>Heliopsis helianthoides</i> (Ox-Eye) <i>Liatris aspera</i> (Rough Blazing Star) <i>Liatris pycnostachya</i> (Prairie Blazing Star) <i>Monarda fistulosa</i> (Prairie Bergamot) <i>Parthenium integrifolium</i> (Wild Quinine) <i>Dalea candida</i> (White Prairie Clover) 4/ <i>Dalea purpurea</i> (Purple Prairie Clover) 4/ <i>Physostegia virginiana</i> (False Dragonhead) <i>Potentilla arguta</i> (Prairie Cinquefoil) <i>Ratibida pinnata</i> (Yellow Coneflower) <i>Rudbeckia subtomentosa</i> (Fragrant Coneflower) <i>Silphium laciniatum</i> (Compass Plant) <i>Silphium terebinthinaceum</i> (Prairie Dock) <i>Oligoneuron rigidum</i> (Rigid Goldenrod) <i>Tradescantia ohiensis</i> (Spiderwort) <i>Veronicastrum virginicum</i> (Culver's Root)			

Class – Type	Seeds	lb/acre (kg/hectare)
5A Large Flower Native Forb Mixture 2/ 5/ 6/	Forb Mixture (see below)	5 (5)
	<u>Species:</u>	<u>% By Weight</u>
	<i>Aster novae-angliae</i> (New England Aster)	5
	<i>Echinacea pallida</i> (Pale Purple Coneflower)	10
	<i>Helianthus mollis</i> (Downy Sunflower)	10
	<i>Heliopsis helianthoides</i> (Ox-Eye)	10
	<i>Liatris pycnostachya</i> (Prairie Blazing Star)	10
	<i>Ratibida pinnata</i> (Yellow Coneflower)	5
	<i>Rudbeckia hirta</i> (Black-Eyed Susan)	10
	<i>Silphium laciniatum</i> (Compass Plant)	10
	<i>Silphium terebinthinaceum</i> (Prairie Dock)	20
	<i>Oligoneuron rigidum</i> (Rigid Goldenrod)	10
5B Wetland Forb 2/ 5/ 6/	Forb Mixture (see below)	2 (2)
	<u>Species:</u>	<u>% By Weight</u>
	<i>Acorus calamus</i> (Sweet Flag)	3
	<i>Angelica atropurpurea</i> (Angelica)	6
	<i>Asclepias incarnata</i> (Swamp Milkweed)	2
	<i>Aster puniceus</i> (Purple Stemmed Aster)	10
	<i>Bidens cernua</i> (Beggarticks)	7
	<i>Eutrochium maculatum</i> (Spotted Joe Pye Weed)	7
	<i>Eupatorium perfoliatum</i> (Boneset)	7
	<i>Helenium autumnale</i> (Autumn Sneezeweed)	2
	<i>Iris virginica shrevei</i> (Blue Flag Iris)	2
	<i>Lobelia cardinalis</i> (Cardinal Flower)	5
	<i>Lobelia siphilitica</i> (Great Blue Lobelia)	5
	<i>Lythrum alatum</i> (Winged Loosestrife)	2
	<i>Physostegia virginiana</i> (False Dragonhead)	5
	<i>Persicaria pensylvanica</i> (Pennsylvania Smartweed)	10
	<i>Persicaria lapathifolia</i> (Curlytop Knotweed)	10
	<i>Pycnanthemum virginianum</i> (Mountain Mint)	5
	<i>Rudbeckia laciniata</i> (Cut-leaf Coneflower)	5
	<i>Oligoneuron riddellii</i> (Riddell Goldenrod)	2
	<i>Sparganium eurycarpum</i> (Giant Burreed)	5
6 Conservation Mixture 2/ 6/	<i>Schizachyrium scoparium</i> (Little Blue Stem) 5/ <i>Elymus canadensis</i> (Canada Wild Rye) 5/ Buffalo Grass 5/ 7/ Vernal Alfalfa 4/ Oats, Spring	5 (5) 2 (2) 5 (5) 15 (15) 48 (55)
6A Salt Tolerant Conservation Mixture 2/ 6/	<i>Schizachyrium scoparium</i> (Little Blue Stem) 5/ <i>Elymus canadensis</i> (Canada Wild Rye) 5/ Buffalo Grass 5/ 7/ Vernal Alfalfa 4/ Oats, Spring <i>Puccinellia distans</i> (Fults Saltgrass or Salty Alkaligrass)	5 (5) 2 (2) 5 (5) 15 (15) 48 (55) 20 (20)
7 Temporary Turf Cover Mixture	Perennial Ryegrass Oats, Spring	50 (55) 64 (70)

Notes:

- 1/ Seeding shall be performed when the ambient temperature has been between 45 °F (7 °C) and 80 °F (27 °C) for a minimum of seven (7) consecutive days and is forecasted to be the same for the next five (5) days according to the National Weather Service.
- 2/ Seeding shall be performed in late fall through spring beginning when the ambient temperature has been below 45 °F (7 °C) for a minimum of seven (7) consecutive days and ending when the ambient temperature exceeds 80 °F (27 °C) according to the National Weather Service.
- 3/ Specific variety as shown in the plans or approved by the Engineer.
- 4/ Inoculation required.
- 5/ Pure Live Seed (PLS) shall be used.
- 6/ Fertilizer shall not be used.
- 7/ Seed shall be primed with  $\text{KNO}_3$  to break dormancy and dyed to indicate such.

Seeding will be inspected after a period of establishment. The period of establishment shall be six (6) months minimum, but not to exceed nine (9) months. After the period of establishment, areas not exhibiting 75 percent uniform growth shall be interseeded or reseeded, as determined by the Engineer, at no additional cost to the Department.”

80445

## HOT-MIX ASPHALT – LONGITUDINAL JOINT SEALANT (BDE)

Effective: November 1, 2022

Revised: August 1, 2023

Add the following after the second sentence in the eighth paragraph of Article 406.06(h)(2) of the Standard Specifications:

“If rain is forecasted and traffic is to be on the LJS or if pickup/tracking of the LJS material is likely, the LJS shall be covered immediately following its application with FA 20 fine aggregate mechanically spread uniformly at a rate of  $1.5 \pm 0.5$  lb/sq yd ( $0.75 \pm 0.25$  kg/sq m). Fine aggregate landing outside of the LJS shall be removed prior to application of tack coat.”

Add the following after the first sentence in the ninth paragraph of Article 406.06(h)(2) of the Standard Specifications:

“LJS half-width shall be applied at a width of  $9 \pm 1$  in. ( $225 \pm 25$  mm) in the immediate lane to be placed with the outside edge flush with the joint of the next HMA lift. The vertical face of any longitudinal joint remaining in place shall also be coated.”

Add the following after the eleventh paragraph of Article 406.06(h)(2) of the Standard Specifications:

“LJS Half-Width Application Rate, lb/ft (kg/m) <sup>1/</sup>			
Lift Thickness, in. (mm)	Coarse Graded Mixture (IL-19.0, IL-19.0L, IL-9.5, IL-9.5L, IL-4.75)	Fine Graded Mixture (IL-9.5FG)	SMA Mixture (SMA-9.5, SMA-12.5)
$\frac{3}{4}$ (19)	0.44 (0.66)		
1 (25)	0.58 (0.86)		
1 $\frac{1}{4}$ (32)	0.66 (0.98)	0.44 (0.66)	
1 $\frac{1}{2}$ (38)	0.74 (1.10)	0.48 (0.71)	0.63 (0.94)
1 $\frac{3}{4}$ (44)	0.82 (1.22)	0.52 (0.77)	0.69 (1.03)
2 (50)	0.90 (1.34)	0.56 (0.83)	0.76 (1.13)
$\geq 2 \frac{1}{4}$ (60)	0.98 (1.46)		

1/ The application rate includes a surface demand for liquid. The thickness of the LJS may taper from the center of the application to a lesser thickness on the edge of the application, provided the correct width and application rate are maintained.”

Revise the second paragraph of Article 406.13(b) of the Standard Specifications to read:

“Aggregate for covering tack, LJS, or FLS will not be measured for payment.”

Add the following to the end of the second paragraph of Article 406.14 of the Standard Specifications:

“Longitudinal joint sealant (LJS) half-width will be paid for at the contract unit price per foot (meter) for LONGITUDINAL JOINT SEALANT, HALF-WIDTH.”

80446

## SOURCE OF SUPPLY AND QUALITY REQUIREMENTS (BDE)

Effective: January 2, 2023

Revised: January 1, 2026

Revise the third through ninth paragraphs of Article 106.01 of the Standard Specifications to read:

“Articles, materials, and supplies shall be classified into only one of the following categories.

- (a) Iron and Steel. All iron and steel products, which are to be incorporated into the work, shall be domestically manufactured or produced and fabricated, unless an exception is expressly permitted under Federal and/or State law and written permission is given by the Department. The Contractor shall obtain from the iron or steel producer and/or fabricator, in addition to the mill analysis, a certification that all iron or steel materials meet these domestic source requirements.

The applications of all coatings, epoxy, galvanizing, painting, etc. to iron and steel products shall be domestically applied.

- (b) Manufactured Products. Manufactured products shall include articles, materials or supplies that have been processed into a specific form or shape; or have been combined with other articles, materials, or supplies to create a product with different properties than the individual articles, materials, or supplies. Manufactured products incorporated into the work shall have the final assembly for the manufacturing process occur domestically.

A manufactured product may include components that are construction materials, iron or steel products, or exempt materials.

Precast concrete products and intelligent transportation systems (ITS) or other electronic hardware systems shall comply with the requirements of Article 106.01(a) in addition to the requirements of manufactured products.

- (c) Construction Materials. All manufacturing processes for construction materials shall occur within the United States. Construction materials shall include an article, material, or supply consisting of only one of the following.

(1) Non-ferrous metals;

(2) Plastic and polymer-based products (including polyvinylchloride, composite building materials, and polymers used in fiber optic cables);

(3) Glass (including optic glass);

(4) Fiber optic cable (including drop cable);

(5) Optical fiber;

(6) Lumber;

(7) Drywall;

(8) Engineered wood.

Minor additions of articles, materials, supplies, or binding agents to a construction material do not change the categorization of the construction material.

(d) Exempt Materials. Materials exempt from domestic production requirements are cement or cementitious materials, aggregates, aggregate binding agents or additives, or items not permanently incorporated into the work. Exempt materials may be combined with other materials into a final form to produce a manufactured product.”

80448

**MECHANICALLY STABILIZED EARTH RETAINING WALLS (BDE)**

Effective: August 1, 2023

Revised: August 1, 2025

Add the following to Article 522.02 of the Standard Specifications:

“(s) Metal Hardware Cast into Concrete ..... 1006.13”

Revise the first paragraph of Article 522.09(b)(1) of the Standard Specifications to read:

“(1) General. At least seven calendar days prior to the start of installation, the Contractor shall meet with the Engineer, supplier, consultants, and subcontractors involved in any part of the MSE wall installation or inspection to outline procedures and ensure proper construction of the wall.”

Revise Article 522.09(b)(5)(a.)(2.) of the Standard Specifications to read:

“2. The maximum allowable offset between adjacent panels shall be 3/4 in. (19 mm).”

Add the following as Article 522.09(b)(5)(a.)(5.) to the Standard Specifications:

“5. The width of each panel joint shall be within 1/4 in. (6 mm) of that shown on the plans.”

Revise the second sentence of Articles 1003.07(d) and 1004.06(d) of the Standard Specifications to read:

“The Illinois Modified AASHTO T 296 test with pore pressure measurement may be used in lieu of AASHTO T 236.”

## FULL LANE SEALANT WATERPROOFING SYSTEM (BDE)

Effective: November 1, 2023

Replace Section 581 of the Standard Specifications with the following:

### “SECTION 581. FULL LANE SEALANT WATERPROOFING SYSTEM

**581.01 Description.** This work shall consist of furnishing and placing a full lane sealant (FLS) waterproofing system over a prepared concrete bridge deck.

**581.02 Materials.** Materials shall be according to the following.

Item	Article/Section
(a) Hot-Mix Asphalt .....	1030
(b) Bituminous Materials (Note 1) .....	1032
(c) Full Lane Sealant (FLS) .....	1032.13

Note 1. The bituminous material used for the tack coat shall be emulsified asphalt according to Article 1032.06. The emulsion producer shall perform any dilution with water. The emulsified asphalt shall be thoroughly agitated within 24 hours of application and show no separation of water and emulsion.

**581.03 Equipment.** Equipment shall be according to Article 406.03 and the following.

(a) Regenerative Air Vacuum Sweeper (Note 1)

Note 1. The regenerative air vacuum sweeper shall blast re-circulated, filtered air through a vacuum head having a minimum width of 6.0 ft (1.83 m) at a minimum rate of 20,000 cu ft/min (560 cu m/min).

### CONSTRUCTION REQUIREMENTS

**581.04 General.** FLS waterproofing system shall be constructed according to Section 406, except as modified herein, with a tack coat, a layer of FLS, a layer of IL-4.75, a second layer of FLS, and a final layer of SMA-9.5 as shown on the plans.

**581.05 Preparation of Concrete Deck.** Surfaces shall be cleaned according to Article 406.05(c). In non-attainment areas, vacuum sweeping shall be performed using a regenerative air vacuum sweeper.

Deck drains shall be temporarily plugged before the tack coat is applied. The material used to plug the drains shall be removed and disposed of upon completion of the work.

From the time the bridge deck is cleaned and prepared for the FLS until the HMA is spread and compacted, the only traffic permitted shall be the necessary workers and equipment to perform the work.

**581.06 Application of Full Lane Sealant Waterproofing System.** FLS shall be applied uniformly to the surface of the bridge deck in a single application per pass with an FLS pressure distributor. Hand application with a squeegee shall be used at places not covered by the FLS pressure distributor.

If FLS pickup occurs, paving shall cease in order for corrective measures to be taken. Corrective measures shall include applying water to the wheels or paving in cooler ambient conditions, and repairing all areas where the pickup occurred.

Before applying the second layer of FLS, remove any standing water from the IL-4.75 binder course.

**581.07 HMA Compaction.** HMA shall be compacted according to Article 406.07, except the density requirement for mixtures on bridge decks shall be replaced with 5 and 7 roller pass coverages per location of IL-4.75 and SMA-9.5 mixtures, respectively.

**581.08 Sequence of Construction Operations.** The sequence of construction operations shall be as follows.

- (a) Tack coat shall be applied at a residual rate of 0.05 lb/sq ft (0.244 kg/sq m).
- (b) FLS shall be applied at a residual rate of 0.25 lb/sq ft (1.21 kg/sq m).
- (c) HMA IL-4.75 binder course shall have a compacted lift thickness of 3/4 in. (19 mm).
- (d) FLS shall be applied at a residual rate of 0.15 lb/sq ft (0.73 kg/sq m).
- (e) HMA SMA-9.5 surface course shall have a compacted lift thickness of 1 1/2 in. (38 mm).

**581.09 Method of Measurement.** This work will be measured for payment as follows.

- (a) Contract Quantities. The requirements for the use of contract quantities shall conform to Article 202.07(a).
- (b) Measured Quantities. This work will be measured for payment and the area computed in square yards (square meters) of the bridge deck surface covered. No measurement or allowance will be made for laps, the material used for extending up curb faces, other vertical barriers, or extensions over lips or edges.

HMA SMA-9.5 will be measured for payment according to Article 406.13(b).

**581.10 Basis of Payment.** This work will be paid for at the contract unit price per square yard (square meter) for FULL LANE SEALANT WATERPROOFING SYSTEM.

HMA SMA-9.5 will be paid for at the contract unit price per ton (metric ton) for POLYMERIZED HOT-MIX ASPHALT SURFACE COURSE, STONE MATRIX ASPHALT, 9.5, of the friction aggregate and Ndesign specified, according to Article 406.14.”

80452

## **CONCRETE SEALER (BDE)**

Effective: November 1, 2023

Replace Section 1026 of the Standard Specifications with the following:

### **“SECTION 1026. CONCRETE SEALER**

**1026.01 General.** Sealer types shall be according to the listing in AASHTO M 224. All concrete sealer types shall meet the sealer requirements of AASHTO M 224 when tested in accordance with AASHTO T 384. The sealer shall be listed on the Department’s qualified product list.

The sealer shall have a clear or amber color when dry.

The Department will perform the sealer characterization properties of ATR-FTIR spectra, total solids, and specific gravity in accordance with AASHTO M 224.”

80453

**WOOD SIGN SUPPORT (BDE)**

Effective: November 1, 2023

Add the following to Article 730.02 of the Standard Specifications:

“(c) Preservative Treatment .....1007.12”

Revise the first paragraph of Article 730.03 of the Standard Specifications to read:

“**730.03 General.** Wood sign supports shall be treated. When the 4 x 6 in. (100 x 150 mm) posts are used, they shall be modified to satisfy the breakaway requirements by drilling 1 1/2 in. (38 mm) diameter holes centered at 4 and 18 in. (100 and 450 mm) above the groundline and perpendicular to the centerline of the roadway.”

80454

## REMOVAL AND DISPOSAL OF REGULATED SUBSTANCES (BDE)

Effective: January 1, 2024

Revised: April 1, 2026

Revise the first paragraph of Article 669.04 of the Standard Specifications to read:

**“669.04 Regulated Substances Monitoring.** Regulated substances monitoring includes environmental observation and field screening during regulated substances management activities. The excavated soil and groundwater within the work areas shall be managed as either uncontaminated soil, hazardous waste, special waste, or non-special waste.

As part of the regulated substances monitoring, the monitoring personnel shall perform and document the applicable duties listed on form BDE 2732 “Regulated Substances Monitoring Daily Record (RSM DR)”.

Revise the first two sentences of the nineteenth paragraph of Article 669.05 of the Standard Specifications to read:

“The Contractor shall coordinate waste disposal approvals with the disposal facility and provide the specific analytical testing requirements of that facility. The Contractor shall make all arrangements for collection, transportation, and analysis of landfill acceptance testing.”

Revise the last paragraph of Article 669.05 of the Standard Specifications to read:

“The Contractor shall select a permitted landfill facility or CCDD/USFO facility meeting the requirements of 35 Ill. Admin. Code Parts 810-814 or Part 1100, respectively. The Department will review and approve or reject the facility proposed by the Contractor based upon information provided in BDE 2730. The Contractor shall verify whether the selected facility is compliant with those applicable standards as mandated by their permit and whether the facility is presently, has previously been, or has never been, on the United States Environmental Protection Agency (U.S. EPA) National Priorities List or the Resource Conservation and Recovery Act (RCRA) List of Violating Facilities. The use of a Contractor selected facility shall in no manner delay the construction schedule or alter the Contractor's responsibilities as set forth.”

Revise the first paragraph of Article 669.07 of the Standard Specifications to read:

**“669.07 Temporary Staging.** Soil classified according to Articles 669.05(a)(2), (b)(1), or (c) may be temporarily staged at the Contractor's option. All other soil classified according to Articles 669.05(a)(1), (a)(3), (a)(4), (a)(5), (a)(6), or (b)(2) shall be managed and disposed of without temporary staging to the greatest extent practicable. If circumstances beyond the Contractor's control require temporary staging of these latter materials, the Contractor shall request approval from the Engineer in writing.

Topsoil for re-use as final cover which has been field screened and found not to exhibit PID readings over daily background readings as documented on the BDE 2732, visual staining or

odors, and is classified according to Articles 669.05(a)(2), (a)(3), (a)(4), (b)(1), or (c) may be temporarily staged at the Contractor's option."

Add the following paragraph after the fourth paragraph of Article 669.10 of the Standard Specifications.

"Regulated substances monitoring will be measured for payment per calendar day, where 4 or more hours of monitoring activities is defined as 1.0 calendar day and less than 4 hours of monitoring activities is defined as 0.5 calendar day."

Revise the second paragraph of Article 669.11 of the Standard Specification to read:

"Regulated substances monitoring, including completion of form BDE 2732 for each day of work, will be paid for at the contract unit price per calendar day for REGULATED SUBSTANCES MONITORING. In no case will more than 1.0 calendar day be paid on a given calendar day."

Add the following paragraph after the sixth paragraph of Article 669.11 of the Standard Specifications.

"The sampling and testing of effluent water derived from dewatering discharges for priority pollutants volatile organic compounds (VOCs), priority pollutants semi-volatile organic compounds (SVOCs), or priority pollutants metals, will be paid for at the contract unit price per each for VOCS GROUNDWATER ANALYSIS using EPA Method 8260B, SVOCs GROUNDWATER ANALYSIS using EPA Method 8270C, or RCRA METALS GROUNDWATER ANALYSIS using EPA Methods 6010B and 7471A. This price shall include transporting the sample from the job site to the laboratory."

Revise the first sentence of the eight paragraph of Article 669.11 of the Standard Specifications to read:

"Payment for temporary staging of soil classified according to Articles 669.05(a)(1), (a)(3), (a)(4), (a)(5), (a)(6), or (b)(2) to be managed and disposed of, if required and approved by the Engineer, will be paid according to Article 109.04."

## **HOT-MIX ASPHALT (BDE)**

Effective: January 1, 2024

Revised: April 1, 2026

Add the following to the end of Article 406.06(c) of the Standard Specifications:

“The amount of HMA binder course placed shall be limited to that which can be surfaced during the same construction season.”

Revise the fifteenth through eighteenth paragraphs of Article 406.14 of the Standard Specifications to read:

“The mixture used in constructing acceptable HMA test strips will be paid for at the contract unit price. Unacceptable HMA test strips shall be removed and replaced at no additional cost to the Department.”

Revise the first and second paragraphs of Articles 1030.06(c)(2) of the Standard Specifications to read:

“(2) Personnel. The Contractor shall provide a QC Manager who shall have overall responsibility and authority for quality control. This individual shall maintain active certification as a Hot-Mix Asphalt Level II technician.

In addition to the QC Manager, the Contractor shall provide sufficient personnel to perform the required visual inspections, sampling, testing, and documentation in a timely manner. Mix designs shall be developed by personnel with an active certification as a Hot-Mix Asphalt Level III technician. Technicians performing mix design testing and plant sampling/testing shall maintain active certification as a Hot-Mix Asphalt Level I technician. The Contractor may provide a technician trainee who has successfully completed the Department’s “Hot-Mix Asphalt Trainee Course” to assist in the activities completed by a Hot-Mix Asphalt Level I technician for a period of one year after the course completion date. The Contractor may also provide a Gradation Technician who has successfully completed the Department’s “Gradation Technician Course” to run gradation tests only under the supervision of a Hot-Mix Asphalt Level II Technician. The Contractor shall provide a Hot-Mix Asphalt Density Tester who has successfully completed the Department’s “Nuclear Density Testing” course to run all nuclear density tests on the job site.”

Add Article 1030.06(d)(3) to the Standard Specifications as follows:

“(3) The Contractor shall take possession of any Department HMA mixture samples or density specimens upon notification by the Engineer. The Contractor shall collect the HMA mixture samples or density specimens from the location designated by the Engineer and may add these materials to RAP stockpiles according to Section 1031.”

Revise the second paragraph of Articles 1030.07(a)(11) and 1030.08(a)(9) of the Standard Specifications to read:

“When establishing the target density, the HMA maximum theoretical specific gravity ( $G_{mm}$ ) will be based on the running average of four available Department test results for that project. If less than four  $G_{mm}$  test results are available, an average of all available Department test results for that project will be used. The initial  $G_{mm}$  will be the last available Department test result from a QMP project. If there is no available Department test result from a QMP project, the Department mix design verification test result will be used as the initial  $G_{mm}$ .”

Revise the Quality Control Limits table in Article 1030.09(c) to read:

“CONTROL LIMITS						
Parameter	IL-19.0, IL-9.5, IL-9.5FG, IL-19.0L, IL-9.5L		SMA-12.5, SMA-9.5		IL-4.75	
	Individual Test	Moving Avg. of 4	Individual Test	Moving Avg. of 4	Individual Test	Moving Avg. of 4
% Passing: <sup>1/</sup>						
1/2 in. (12.5 mm)	± 6 %	± 4 %	± 6 %	± 4 %		
3/8 in. (9.5mm)			± 4 %	± 3 %		
# 4 (4.75 mm)	± 5 %	± 4 %	± 5 %	± 4 %		
# 8 (2.36 mm)	± 5 %	± 3 %	± 4 %	± 2 %		
# 16 (1.18 mm)			± 4 %	± 2 %	± 4 %	± 3 %
# 30 (600 µm)	± 4 %	± 2.5 %	± 4 %	± 2.5 %		
Total Dust Content # 200 (75 µm)	± 1.5 %	± 1.0 %			± 1.5 %	± 1.0 %
Asphalt Binder Content	± 0.3 %	± 0.2 %	± 0.2 %	± 0.1 %	± 0.3 %	± 0.2 %
Air Voids <sup>2/</sup>	± 1.2 %	± 1.0 %	± 1.2 %	± 1.0 %	± 1.2 %	± 1.0 %
Field VMA <sup>3/</sup>	-0.7 %	-0.5 %	-0.7 %	-0.5 %	-0.7 %	-0.5 %

1/ Based on washed ignition oven or solvent extraction gradation.

2/ The air voids target value shall be 3.2 to 4.8 percent.

3/ Allowable limit below minimum design VMA requirement.”

Revise Article 1030.09(g)(1) of the Supplemental Specifications with the following:

“(1) The Contractor shall sample approximately 200 lb (91 kg) of mix as required for the Department’s random mixture verification tests according to Article 1030.09(h)(1).”

Revise Article 1030.09(g)(2) of the Standard Specifications to read:

“(2) The Contractor shall complete split verification sample tests listed in the Limits of Precision table in Article 1030.09(h)(1).”

Revise the second sentence of Article 1030.09(h)(1) of the Supplemental Specifications with the following:

“The random verification mixture sampling interval will be a maximum of 3,000 tons (2,720 metric tons). The Engineer will randomly identify one sample per interval, with a minimum of one sample per mix. If the remaining mix quantity is 600 tons (544 metric tons) or less, the quantity will be combined with the previous interval in the Engineer’s random sample identification. If the required tonnage of a mixture for a single pay item is less than 250 tons (225 metric tons) in total, the Engineer will waive mixture verification sampling and testing.”

Revise the third paragraph of Article 1030.09(h)(1) of the Standard Specifications to read:

“If comparisons of the mixture verification test results are outside the above limits of precision, the Department will verify the results by testing the retained split sample. The retest results will replace all the original results.”

In the Supplemental Specifications, replace the revision for the end of the third paragraph of Article 1030.09(h)(2) with the following:

“When establishing the target density, the HMA maximum theoretical specific gravity ( $G_{mm}$ ) will be the Department mix design verification test result.”

Replace the last sentence of the fourth paragraph of Article 1030.10 of the Standard Specifications with the following:

“The mixture test results shall meet the requirements of Article 1030.05(d), except tensile strength and TSR testing will only be conducted on the first use of a mix design for the year and Hamburg wheel tests will only be conducted on High ESAL mixtures. To be considered acceptable to remain in place, the Department’s mixture test results shall meet the acceptable limits stated in Article 1030.09(i)(1). In addition, no visible pavement distress such as, but not limited to, segregation, excessive coarse aggregate fracturing outside of growth curves, excessive dust balls, or flushing shall be present as determined by the Engineer.”

Revise the tenth paragraph of Article 1030.10 of the Standard Specifications to read:

“Production is not required to stop after a test strip has been constructed.”

Replace the eleventh paragraph of Article 1030.10 of the Standard Specifications with the following:

“If an initial Hamburg wheel or I-FIT test fails to meet the requirements of Article 1030.05(d), the Department will verify the results by testing the retained gyratory cylinders. Upon notification by the Engineer of a Hamburg wheel or I-FIT test failure on the retained gyratory cylinders, the Contractor shall substitute an approved mix design, submit a new mix design for mix verification testing according to Article 1030.05(d), or pave 250 tons with or without an adjustment and resample for Department Hamburg wheel and I-FIT testing as directed by the Engineer. Paving may continue as long as all other mixture criteria is being met. If Hamburg wheel or I-FIT tests on the resampled HMA fail, production of the affected mixture shall cease and the Contractor shall substitute an approved mix design or submit a new mix design for mix verification testing according to Article 1030.05(d).”

80456

## SHORT TERM AND TEMPORARY PAVEMENT MARKINGS (BDE)

Effective: April 1, 2024

Revised: April 2, 2024

Revise Article 701.02(d) of the Standard Specifications to read:

“(d) Pavement Marking Tapes (Note 3) ..... 1095.06”

Add the following Note to the end of Article 701.02 of the Standard Specifications:

“Note 3. White or yellow pavement marking tape that is to remain in place longer than 14 days shall be Type IV tape.”

Revise Article 703.02(c) of the Standard Specifications to read:

“(c) Pavement Marking Tapes (Note 1) ..... 1095.06”

Add the following Note to the end of Article 703.02 of the Standard Specifications:

“Note 1. White or yellow pavement marking tape that is to remain in place longer than 14 days shall be Type IV tape.”

Revise Article 1095.06 of the Standard Specifications to read:

**“1095.06 Pavement Marking Tapes.** Type I white or yellow marking tape shall consist of glass spheres embedded into a binder on a foil backing that is precoated with a pressure sensitive adhesive. The spheres shall be of uniform gradation and distributed evenly over the surface of the tape.

Type IV tape shall consist of white or yellow tape with wet reflective media incorporated to provide immediate and continuing retroreflection in wet and dry conditions. The wet retroreflective media shall be bonded to a durable polyurethane surface. The patterned surface shall have approximately  $40 \pm 10$  percent of the surface area raised and presenting a near vertical face to traffic from any direction. The channels between the raised areas shall be substantially free of exposed reflective elements or particles.

Blackout tape shall consist of a matte black, non-reflective, patterned surface that is precoated with a pressure sensitive adhesive.

- (a) Color. The white and yellow markings shall meet the following requirements for daylight reflectance and color, when tested, using a color spectrophotometer with 45 degrees circumferential/zero degree geometry, illuminant D65, and two degree observer angle. The color instrument shall measure the visible spectrum from 380 to 720 nm with a wavelength measurement interval and spectral bandpass of 10 nm.

Color	Daylight Reflectance %Y
White	65 min.
Yellow *	36 - 59

\*Shall match Aerospace Material Specification Standard 595 33538 (Orange Yellow) and the chromaticity limits as follows.

x	0.490	0.475	0.485	0.530
y	0.470	0.438	0.425	0.456

- (b) Retroreflectivity. The white and yellow markings shall be retroreflective. Reflective values measured in accordance with the photometric testing procedure of ASTM D 4061 shall not be less than those listed in the table below. The coefficient of retroreflected luminance,  $R_L$ , shall be expressed as average millicandelas/footcandle/sq ft (millicandelas/lux/sq m), measured on a 3.0 x 0.5 ft (900 mm x 150 mm) panel at 86 degree entrance angle.

Coefficient of Retroreflected Luminance, $R_L$ , Dry					
Type I			Type IV		
Observation Angle	White	Yellow	Observation Angle	White	Yellow
0.2°	2700	2400	0.2°	1300	1200
0.5°	2250	2000	0.5°	1100	1000

Wet retroreflectance shall be measured for Type IV under wet conditions according to ASTM E 2177 and meet the following.

Wet Retroreflectance, Initial $R_L$	
Color	$R_L$ 1.05/88.76
White	300
Yellow	200

- (c) Skid Resistance. The surface of Type IV and blackout markings shall provide a minimum skid resistance of 45 BPN when tested according to ASTM E 303.
- (d) Application. The pavement marking tape shall have a precoated pressure sensitive adhesive and shall require no activation procedures. Test pieces of the tape shall be applied according to the manufacturer's instructions and tested according to ASTM D 1000, Method A, except that a stiff, short bristle roller brush and heavy hand pressure will be substituted for the weighted rubber roller in applying the test pieces to the metal test panel. Material tested as directed above shall show a minimum adhesion value of 750 g/in. (30 g/mm) width at the temperatures specified in ASTM D 1000. The adhesive shall be resistant to oils, acids, solvents, and water, and shall not leave objectionable stains or residue after removal. The material shall be flexible and conformable to the texture of the pavement.

(e) Durability. Type IV and blackout tape shall be capable of performing for the duration of a normal construction season and shall then be capable of being removed intact or in large sections at pavement temperatures above 40 °F (4 °C) either manually or with a roll-up device without the use of sandblasting, solvents, or grinding. The Contractor shall provide a manufacturer's certification that the material meets the requirements for being removed after the following minimum traffic exposure based on transverse test decks with rolling traffic.

- (1) Time in place - 400 days
- (2) ADT per lane - 9,000 (28 percent trucks)
- (3) Axle hits - 10,000,000 minimum

Samples of the material applied to standard specimen plates will be measured for thickness and tested for durability in accordance with ASTM D 4060, using a CS-17 wheel and 1000-gram load, and shall meet the following criteria showing no significant change in color after being tested for the number of cycles indicated.

Test	Type I	Type IV	Blackout
Minimum Initial Thickness, mils (mm)	20 (0.51)	65 (1.65) <sup>1/</sup> 20 (0.51) <sup>2/</sup>	65 (1.65) <sup>1/</sup> 20 (0.51) <sup>2/</sup>
Durability (cycles)	5,000	1,500	1,500

1/ Measured at the thickest point of the patterned surface.

2/ Measured at the thinnest point of the patterned surface.

The pavement marking tape, when applied according to the manufacturer's recommended procedures, shall be weather resistant and shall show no appreciable fading, lifting, or shrinkage during the useful life of the marking. The tape, as applied, shall be of good appearance, free of cracks, and edges shall be true, straight, and unbroken.

(f) Sampling and Inspection.

(1) Sample. Prior to approval and use of Type IV pavement marking tape, the manufacturer shall submit a notarized certification from an independent laboratory, together with the results of all tests, stating that the material meets the requirements as set forth herein. The independent laboratory test report shall state the lot tested, the manufacturer's name, and the date of manufacture.

After initial approval by the Department, samples and certification by the manufacturer shall be submitted for each subsequent batch of Type IV tape used. The manufacturer shall submit a certification stating that the material meets the requirements as set forth herein and is essentially identical to the material sent for qualification. The certification shall state the lot tested, the manufacturer's name, and the date of manufacture.

- (2) Inspection. The Contractor shall provide a manufacturer's certification to the Engineer stating the material meets all requirements of this specification. All material samples for acceptance tests shall be taken or witnessed by a representative of the Bureau of Materials and shall be submitted to the Engineer of Materials, 126 East Ash Street, Springfield, Illinois 62704-4766 at least 30 days in advance of the pavement marking operations."

80457

## **WATERPROOFING MEMBRANE SYSTEM (BDE)**

Effective: August 1, 2024

Revise Article 1061.03 of the Standard Specifications to read:

**“1061.03 Coal Tar Pitch Emulsion.** The coal tar pitch emulsion shall be compounded of heavy closed ring hydrocarbons dispersed in water by means of a combination of irreversible colloidal clays meeting ASTM D 5727. The Contractor shall submit a manufacturer’s certification stating it meets these requirements.”

80458

## **PREFORMED PLASTIC PAVEMENT MARKING (BDE)**

Effective: June 2, 2024

Revise Article 1095.03(h) of the Standard Specifications to read:

“(h) Glass Beads. Glass beads shall be colorless and uniformly distributed throughout the yellow and white portions of the material only. A top coating of beads shall be bonded to or directly embedded into the surface of the markings such that the beads are not easily removed when the film is scratched firmly with a thumb nail.

The glass bead refractive index shall be tested using the liquid immersion method.

Type B material shall have an inner mix of glass beads with a minimum refractive index of 1.50 and a top coating of ceramic beads bonded to top urethane wear surface with a minimum refractive index of 1.70. Beads with a refractive index greater than 1.80 shall not be used.

Type C material shall have glass beads with a minimum refractive index of 1.50 and a layer of skid resistant ceramic particles bonded to the top urethane wear surface. The urethane wear surface shall have a nominal thickness of 5 mils (0.13 mm).”

Revise Article 1095.03(n) of the Standard Specifications to read:

“(n) Sampling and Inspection.

(1) Sample. Prior to approval and use of preformed plastic pavement markings, the manufacturer shall submit a notarized certification from an independent laboratory, together with the results of all tests, stating that the material meets the requirements as set forth herein. The independent laboratory test report shall state the lot tested, the manufacturer’s name, and the date of manufacture.

After initial approval by the Department, samples and certification by the manufacturer shall be submitted for each subsequent batch used. The manufacturer shall submit a certification stating that the material meets the requirements as set forth herein and is essentially identical to the material sent for qualification. The certification shall state the lot tested, the manufacturer’s name, and the date of manufacture.

(2) Inspection. The Contractor shall provide a manufacturer’s certification to the Engineer stating the material meets all requirements of this specification. All material samples for acceptance tests will be taken or witnessed by a representative of the Bureau of Materials and will be submitted to the Engineer of Materials, 126 East Ash Street, Springfield, Illinois 62704-4766 at least 30 days in advance of the pavement marking operations.”

**CEMENT, FINELY DIVIDED MINERALS, ADMIXTURES, CONCRETE, AND MORTAR (BDE)**

Effective: January 1, 2025

Revised: January 1, 2026

Revise the first paragraph of Article 285.05 of the Standard Specifications to read:

**“285.05 Fabric Formed Concrete Revetment Mat.** The grout shall consist of a mixture of cement, fine aggregate, and water so proportioned and mixed as to provide a pumpable slurry. Fly ash or ground granulated blast furnace (GGBF) slag, and concrete admixtures may be used at the option of the Contractor. The grout shall have an air content of not less than 6.0 percent nor more than 9.0 percent of the volume of the grout. The mix shall obtain a compressive strength of 2500 psi (17,000 kPa) at 28 days according to Article 1020.09.”

Revise Article 302.02 of the Standard Specifications to read:

**“302.02 Materials.** Materials shall be according to the following.

Item	Article/Section
(a) Cement .....	1001
(b) Water .....	1002
(c) Hydrated Lime .....	1012.01
(d) By-Product, Hydrated Lime .....	1012.02
(e) By-Product, Non-Hydrated Lime .....	1012.03
(f) Lime Slurry .....	1012.04
(g) Fly Ash .....	1010
(h) Soil for Soil Modification (Note 1) .....	1009.01
(i) Bituminous Materials (Note 2) .....	1032

Note 1. This soil requirement only applies when modifying with lime (slurry or dry).

Note 2. The bituminous materials used for curing shall be emulsified asphalt RS-2, CRS-2, HFE 90, or HFE 150; rapid curing liquid asphalt RC-70; or medium curing liquid asphalt MC-70 or MC-250.”

Revise Article 312.07(c) of the Standard Specifications to read:

“(c) Cement ..... 1001”

Add Article 312.07(i) of the Standard Specifications to read:

“(i) Ground Granulated Blast Furnace (GGBF) Slag ..... 1010”

Revise the first paragraph of Article 312.09 of the Standard Specifications to read:

**“312.09 Proportioning and Mix Design.** At least 60 days prior to start of placing CAM II, the Contractor shall submit samples of materials to be used in the work for proportioning and testing. The mixture shall contain a minimum of 200 lb (120 kg) of cement per cubic yard (cubic meter). Cement may be replaced with fly ash or ground granulated blast furnace (GGBF) slag according to Article 1020.05(c)(1) or 1020.05(c)(2), respectively, however the minimum cement content in the mixture shall be 170 lbs/cu yd (101 kg/cu m). Blends of coarse and fine aggregates will be permitted, provided the volume of fine aggregate does not exceed the volume of coarse aggregate. The Engineer will determine the proportions of materials for the mixture according to the “Portland Cement Concrete Level III Technician Course” manual. However, the Contractor may substitute their own mix design. Article 1020.05(a) shall apply, and a Level III PCC Technician shall develop the mix design.”

Revise Article 352.02 of the Standard Specifications to read:

**“352.02 Materials.** Materials shall be according to the following.

Item	Article/Section
(a) Cement (Note 1) .....	1001
(b) Soil for Soil-Cement Base Course .....	1009.03
(c) Water .....	1002
(d) Bituminous Materials (Note 2) .....	1032

Note 1. Bulk cement may be used for the traveling mixing plant method if the equipment for handling, weighing, and spreading the cement is approved by the Engineer.

Note 2. The bituminous materials used for curing shall be emulsified asphalt RS-2, CRS-2, HFE 90, or HFE 150; rapid curing liquid asphalt RC-70; or medium curing liquid asphalt MC-70 or MC-250.”

Revise Article 404.02 of the Standard Specifications to read:

**“404.02 Materials.** Materials shall be according to the following.

Item	Article/Section
(a) Cement .....	1001
(b) Water .....	1002
(c) Fine Aggregate .....	1003.08
(d) Bituminous Material (Tack Coat) .....	1032.06
(e) Emulsified Asphalts (Note 1) (Note 2) .....	1032.06
(f) Fiber Modified Joint Sealer .....	1050.05
(g) Additives (Note 3)	

Note 1. When used for slurry seal, the emulsified asphalt shall be CQS-1h according to Article 1032.06(b).

Note 2. When used for micro-surfacing, the emulsified asphalt shall be CQS-1hP according to Article 1032.06(e).

Note 3. Additives may be added to the emulsion mix or any of the component materials to provide the control of the quick-traffic properties. They shall be included as part of the mix design and be compatible with the other components of the mix.

Revise the last sentence of the fourth paragraph of Article 404.08 of the Standard Specifications to read:

“When approved by the Engineer, the sealant may be dusted with fine sand, cement, or mineral filler to prevent tracking.”

Revise Note 2 of Article 516.02 of the Standard Specifications to read:

“Note 2. The sand-cement grout mix shall be according to Section 1020 and shall be a 1:1 blend of sand and cement comprised of a Type I, IL, or II cement at 185 lb/cu yd (110 kg/cu m). The maximum water cement ratio shall be sufficient to provide a flowable mixture with a typical slump of 10 in. (250 mm).”

Revise Note 2 of Article 543.02 of the Standard Specifications to read:

“Note 2. The grout mixture shall be 6.50 hundredweight/cu yd (385 kg/cu m) of cement plus fine aggregate and water. Fly ash or ground granulated blast furnace (GGBF) slag may replace a maximum of 5.25 hundredweight/cu yd (310 kg/cu m) of the cement. The water/cement ratio, according to Article 1020.06, shall not exceed 0.60. An air-entraining admixture shall be used to produce an air content, according to Article 1020.08, of not less than 6.0 percent nor more than 9.0 percent of the volume of the grout. The Contractor shall have the option to use a water-reducing or high range water-reducing admixture.”

Revise Article 583.01 of the Standard Specifications to read:

“**583.01 Description.** This work shall consist of placing cement mortar along precast, prestressed concrete bridge deck beams as required for fairing out any unevenness between adjacent deck beams prior to placing of waterproofing membrane and surfacing.”

Revise Article 583.02(a) of the Standard Specifications to read:

“(a) Cement ..... 1001”

Revise the first paragraph of Article 583.03 of the Standard Specifications to read:

“**583.03 General.** This work shall only be performed when the air temperature is 45 °F (7 °C) and rising. The mixture for cement mortar shall consist of three parts sand to one part cement by volume. The amount of water shall be no more than that necessary to produce a workable, plastic mortar.”

Revise Article 606.02(h) of the Standard Specifications to read:

“(h) Fibers (Note 1) .....1014”

Revise Note 1 in Article 606.02(h) of the Standard Specifications to read:

“Note 1. Fibers, when required, shall only be used in the concrete mixture for slipform applications.”

Revise the third paragraph in Article 606.10 of the Standard Specifications to read:

“Welded wire fabric shall be 6 x 6 in. (150 x 150 mm) mesh, #4 gauge (5.74 mm), 58 lb (26 kg) per 100 sq ft (9 sq m).”

Revise Article 1001.01(d) of the Standard Specifications to read:

“(d) Rapid Hardening Cement. Rapid hardening cement shall be according to the Bureau of Materials Policy Memorandum “Portland or Blended Cement Acceptance Procedure for Qualified and Non-Qualified Plants”, and ASTM C 1600, Type URH, Type VRH, or Type RH-CAC. It shall be used according to Article 1020.04 or when approved by the Engineer. The Contractor shall submit a report from the manufacturer or an independent lab that contains results for testing according to ASTM C 1600 which shows the cement meets the requirements of either Type URH, Type VRH, or Type RH-CAC. Test data shall be less than 1 year old from the date of submittal.

Revise Article 1001.01(e) of the Standard Specifications to read:

“(e) Other Cements. Other cements shall be according to the Bureau of Materials Policy Memorandum “Portland or Blended Cement Acceptance Procedure for Qualified and Non-Qualified Plants”, and ASTM C 1157 or ASTM C 1600, as applicable. Other cements shall be used according to Article 1020.04 or when approved by the Engineer. For cements according to ASTM C 1157, the Contractor shall submit a report from the manufacturer or an independent lab that contains results of tests which shows the cement meets the requirements Type GU, HE, MS, MH, or LH. For cements according to ASTM C 1600, the Contractor shall submit a report from the manufacturer or an independent lab that contains results of tests which shows the cement meets the requirements Type MRH or GRH. Test data shall be less than 1 year old from the date of submittal.”

Revise Article 1002.02 of the Standard Specifications to read:

“**1002.02 Quality.** Water used with cement in concrete or mortar and water used for curing concrete shall be clean, clear, and free from sugar. In addition, water shall be tested and evaluated for acceptance according to one of the following options.

OPTION 1.

(a) Acceptable limits for acidity and alkalinity when tested according to ITP T 26.

- (1) Acidity -- 0.1 Normal NaOH ..... 2 ml max.\*
  - (2) Alkalinity -- 0.1 Normal HCl..... 10 ml max.\*
- \*To neutralize 200 ml sample.

(b) Acceptable limits for solids when tested according to the following.

- (1) Organic (ITP T 26)..... 0.02% max.
- (2) Inorganic (ITP T 26)..... 0.30% max.
- (3) Sulfate (SO<sub>4</sub>) (ASTM D 516-82) ..... 0.05% max.
- (4) Chloride (ASTM D 512) ..... 0.06% max.

(c) The following tests shall be performed on the water sample and on deionized water. The same cement and sand shall be used for both tests.

- (1) Unsoundness (ASTM C 151).
- (2) Initial and Final Set Time (ASTM C 266).
- (3) Strength (ASTM C 109).

The test results for the water sample shall not deviate from the test results for the deionized water, except as allowed by the precision in the test method.

OPTION 2. Water shall meet the requirements ASTM C 1602 Tables 1 and 2 as outlined in Sections 5.1, 5.2, and 5.4.”

Revise Note 2/ in Article 1003.01(b) of the Standard Specifications to read:

“2/ Applies only to sand. Sand exceeding the colorimetric test standard of 11 (Illinois Modified AASHTO T 21) will be checked for mortar making properties according to Illinois Modified ASTM C 87 and shall develop a compressive strength at the age of 14 days when using Type I, IL, or II cement of not less than 95 percent of the comparable standard.

Revise the second sentence of Article 1003.02(e)(1) of the Standard Specifications to read:

“The test will be performed with Type I, IL, or II portland cement having a total equivalent alkali content (Na<sub>2</sub>O + 0.658K<sub>2</sub>O) of 0.90 percent or greater.”

Revise the first sentence of the second paragraph of Article 1003.02(e)(3) of the Standard Specifications to read:

“The ASTM C 1293 test shall be performed with Type I, IL, or II portland cement having a total equivalent alkali content (Na<sub>2</sub>O + 0.658K<sub>2</sub>O) of 0.80 percent or greater.”

Revise the second sentence of Article 1004.02(g)(1) of the Standard Specifications to read:

“The test will be performed with Type I, IL, or II portland cement having a total equivalent alkali content ( $\text{Na}_2\text{O} + 0.658\text{K}_2\text{O}$ ) of 0.90 percent or greater.”

Add the following Section to the Standard Specifications.

#### **“SECTION 1014. FIBERS FOR CONCRETE**

**1014.01 General.** Fibers used in concrete shall be Type II or Type III (polyolefin or carbon) according to ASTM C 1116. The testing required for Type II fibers or Type III polyolefin fibers shall be performed by an independent lab a minimum of once every five years, and the test results provided to the Department. Manufacturers of Type III carbon fibers shall provide materials certification documentation not more than 6 years old a minimum of once every 5 years to the Department. The Department will maintain a qualified product list. The method of inclusion of fibers into concrete mixtures shall be according to the manufacturer’s specifications.

At the discretion of the Engineer, the concrete mixture shall be evaluated in a field demonstration for fiber clumping, ease of placement, and ease of finishing. The field demonstration shall consist of a minimum 2 cu yd (1.5 cu m) trial batch placed in a 12 ft x 12 ft (3.6 m x 3.6 m) slab.

**1014.02 Concrete Gutter, Curb, Median and Paved Ditch.** Fibers shall be Type III. Fibers shall have a minimum length of 1/2 in. (13 mm) and a maximum length of 0.75 in. (19 mm). The maximum dosage rate in the concrete mixture shall not exceed 1.5 lb/cu yd (0.9 kg/cu m). The minimum dosage rate shall be per the manufacturer’s recommendation.

**1014.03 Concrete Inlay or Overlay.** Fibers shall be Type III. Fibers shall have a minimum length of 1.0 in. (25 mm), a maximum length of 2 1/2 in. (63 mm), and a maximum aspect ratio (length divided by the equivalent diameter of the fiber) of 150. The maximum dosage rate shall not exceed 5.0 lb/cu yd (3.0 kg/cu m). The minimum dosage rate shall be per the manufacturer’s recommendation.

**1014.04 Bridge Deck Fly Ash, Ground Granulated Blast Furnace (GGBF) Slag, High Reactivity Metakaolin, or Microsilica (Silica Fume) Concrete Overlay.** Fibers shall be Type III. The dosage rate shall be a minimum of 3.0 lb/cu yd (1.8 kg/cu m), unless a field demonstration according to Article 1014.01 indicates that a lower dosage rate is necessary. Based on the results of the field demonstration, the Department has the option to reduce the dosage rate of fibers, but the dosage will not be reduced to less than 2.0 lb / cu yd (1.2 kg/cu m).

**1014.05 Bridge Deck Latex Concrete Overlay.** Fibers shall be Type II or III. Fibers shall have a minimum length of 0.75 in. (19 mm), a maximum length of 1.75 in. (45 mm), and an aspect ratio (length divided by the equivalent diameter of the fiber) of between 70 and 100. The dosage rate shall be a minimum of 3.0 lb/cu yd (1.8 kg/cu m), unless a field demonstration according to Article 1014.01 indicates that a lower dosage rate is necessary. Based on the results of the field

demonstration, the Department has the option to reduce the dosage rate of fibers, but the dosage will not be reduced to less than 2.0 lb/cu yd (1.2 kg/cu m).”

Add the following Section to the Standard Specifications:

### **“SECTION 1015. HIGH PERFORMANCE SHOTCRETE**

**1015.01 Packaged Shotcrete With Aggregate.** The packaged shotcrete with aggregate shall be a pre-blended dry combination of materials for the wet-mix shotcrete method according to ASTM C 1480, Type FA or CA, Grade FR, Class I. The fibers shall be Type III according to Article 1014.01. The cement and finely divided minerals in the mixture shall be a minimum 6.65 cwt/cu yd (395 kg/cu m), and the portland cement shall not be below 4.70 cwt/cu yd (279 kg/cu m). Microsilica is required in the mixture and shall be a minimum of 5 percent by weight (mass) of cementitious material, and a maximum of 10 percent. Strength requirements shall be according to ASTM C 1480 except that the strength at 28 days shall be at least 4000 psi (27,500 kPa). Strength testing shall be according to ASTM C 1140. The air content as shot shall be 4.0 – 8.0 percent when tested according to AASHTO T 152, and the coarse aggregate shall be a maximum size of 1/2 in. (12.5 mm).

The packaged shotcrete shall have a water soluble chloride ion content of less than 0.15% by weight of cementitious material when tested according to ASTM C 1218 or AASHTO T 260.

The testing according to ASTM C 1480, ASTM C 1140, AASHTO 152, and ASTM C 1218 or AASHTO T 260 shall be performed by an independent lab a minimum of once every 5 years, and the test results shall be provided to the Department. The Department will maintain a qualified product list. Batching and mixing shall be per the manufacturer’s recommendations.

**1015.02 Packaged Shotcrete Without Aggregate.** The packaged shotcrete that does not include pre-blended aggregate shall be according to Article 1015.01, except the added aggregate shall be according to Articles 1003.02 and 1004.02. The aggregate gradation shall be according to the manufacturer. The Department will maintain a qualified product list. Batching and mixing shall be per the manufacturer’s recommendations.”

Revise Section 1017 of the Standard Specifications to read:

### **“SECTION 1017. PACKAGED, DRY, COMBINED MATERIALS FOR MORTAR AND CONCRETE**

**1017.01 Mortar.** The mortar shall be high-strength according to ASTM C 387 and shall have a minimum 80.0 percent relative dynamic modulus of elasticity when tested according to AASHTO T 161. For prestressed concrete applications, the mortar shall have a water-soluble chloride ion content of less than 0.06 percent by weight of cementitious material when tested according to ASTM C 1218 or AASHTO T 260; and for non-prestressed concrete applications, the water soluble chloride content shall be less than 0.15 percent by weight of cementitious material. The testing according to ASTM C 387, AASHTO T 161, and either ASTM C 1218 or AASHTO T 260 shall be performed by an independent lab a minimum of once every five years, and the test results

shall be provided to the Department. The Department will maintain a qualified product list. Mixing of the high-strength mortar shall be according to the manufacturer's specifications.

**1017.02 Concrete.** The materials, testing, and preparation of aggregate for the "high slump" packaged concrete mixture shall be according to ASTM C 387. The mixture shall be air entrained, the slump shall be 5-10 in. (125-250 mm), and the coarse aggregate shall be a maximum size of 1/2 in. (12.5 mm). Strength requirements shall be according to ASTM C 387 except that the strength at 28 days shall be at least 4000 psi (27,500 kPa). The "high slump" packaged concrete mixture shall have a water soluble chloride ion content of less than 0.15% by weight of cementitious material when tested according to ASTM C 1218 or AASHTO T 260. The testing according to ASTM C 387, and either ASTM C 1218 or AASHTO T 260 shall be performed by an independent lab a minimum of once every 5 years, and the test results shall be provided to the Department. The Department will maintain a qualified product list. Mixing shall be per the manufacturer's recommendations.

**1017.02 Self-Consolidating Concrete.** The materials, testing, and preparation of aggregate for the "self-consolidating concrete" packaged concrete mixture shall be according to ASTM C 387. The mixture shall be air entrained, it should be uniformly graded, and the coarse aggregate shall be a maximum size of 1/2 in. (12.5 mm). Strength requirements shall be according to ASTM C 387 except that the strength at 28 days shall be at least 4000 psi (27,500 Pa). Slump flow range shall be 22 in. (550 mm) minimum to 28 in. (700 mm) maximum when tested according to AASHTO T 347. The visual stability index shall be a maximum of 1 when tested according to AASHTO T 351. At the option of the manufacturer, either the J-Ring value shall be a maximum of 2 in. (50 mm) when tested according to AASHTO T 347 or the L-Box blocking ratio shall be a minimum of 80 percent when tested according AASHTO T 419. The hardened visual stability index shall be a maximum of 1 when tested according to AASHTO R 81.

The "self -consolidating concrete" packaged concrete mixture shall have a water soluble chloride ion content of less than 0.15 percent by weight of cementitious material when tested according to ASTM C 1218 or AASHTO T 260.

The testing according to ASTM C 387, AASHTO T 347, AASHTO T 351, AASHTO T 419, AASHTO R 81, ASTM C 1218 and AASHTO T 260 shall be performed by an independent lab a minimum of once every 5 years, and the test results shall be provided to the Department. The Department will maintain a qualified product list. Mixing shall be per the manufacturer's recommendations."

Revise Article 1018.01 of the Standard Specifications to read:

**"1018.01 Requirements.** The rapid hardening mortar or concrete shall be according to ASTM C 928 and shall have successfully completed and remain current with the AASHTO Product Eval and Audit Rapid Hardening Concrete Patching Materials (RHCP) testing program. R1, R2, or R3 concrete shall be air entrained, the slump shall be 5-10 in. (125-250 mm), and the coarse aggregate shall be a maximum size of 1/2 in. (12.5 mm). For prestressed concrete applications, the mortar or concrete shall have a water-soluble chloride ion content of less than 0.06 percent by weight of cementitious material when tested according to ASTM C 1218 or AASHTO T 260;

and for non-prestressed concrete applications, the water soluble chloride content shall be less than 0.15 percent by weight of cementitious material. The Department will maintain a qualified product list. Mixing of the mortar or concrete shall be according to the manufacturer's specifications..”

Revise Article 1019.02 of the Standard Specifications to read:

“**1019.02 Materials.** Materials shall be according to the following.

Item	Article/Section
(a) Cement .....	1001
(b) Water .....	1002
(c) Fine Aggregate for Controlled Low-Strength Material (CLSM) .....	1003.06
(d) Fly Ash .....	1010
(e) Ground Granulated Blast Furnace (GGBF) Slag.....	1010
(f) Admixtures (Note 1)	

Note 1. The air-entraining admixture may be in powder or liquid form. The air content produced by the admixture shall be 15-25 percent when incorporated into Mix 2 or an equivalent mixture as determined by the Department and tested according to AASHTO T 121 or AASHTO T 152. The testing according to AASHTO T 121 or AASHTO T 152 shall be performed by an independent lab a minimum of once every five years, and the test results shall be provided to the Department. The Department will maintain a qualified product list.”

Revise the third paragraph of Article 1019.04 of the Standard Specifications to read:

“The Engineer will instruct the Contractor to adjust the proportions of the mix design in the field as needed to meet the design criteria, provide adequate flowability, maintain proper solid suspension, or other criteria established by the Engineer.”

Revise Article 1019.05 of the Standard Specifications to read:

“**1019.05 Department Mix Design.** The Department mix design shall be Mix 1, 2, or 3 and shall be proportioned to yield approximately one cubic yard (cubic meter).

Mix 1	
Cement	50 lb (30 kg)
Fly Ash – Class C or F, and/or GGBF Slag	125 lb (74 kg)
Fine Aggregate – Saturated Surface Dry	2900 lb (1720 kg)
Water	50-65 gal (248-322 L)
Air Content	No air is entrained

Mix 2	
Cement	125 lb (74 kg)

Fine Aggregate – Saturated Surface Dry	2500 lb (1483 kg)
Water	35-50 gal (173-248 L)
Air Content	15-25 %

Mix 3	
Cement	40 lb (24 kg)
Fly Ash – Class C or F, and/or GGBF Slag	125 lb (74 kg)
Fine Aggregate – Saturated Surface Dry	2500 lb (1483 kg)
Water	35-50 gal (179-248 L)
Air Content	15-25 %

Revise Article 1020.04, Table 1, Note (8) of the Standard Specifications to read:

“(8) In addition to the Type III portland cement, 100 lb/cu yd of ground granulated blast-furnace slag and 50 lb/cu yd of microsilica (silica fume) shall be used. For an air temperature greater than 85 °F, the Type III portland cement may be replaced with Type I, IL, or II portland cement.”

Revise Article 1020.04, Table 1 (Metric), Note (8) of the Standard Specifications to read:

“(8) In addition to the Type III portland cement, 60 kg/cu m of ground granulated blast-furnace slag and 30 kg/cu m of microsilica (silica fume) shall be used. For an air temperature greater than 30 °C, the Type III portland cement may be replaced with Type I, IL, or II portland cement.”

Revise Note 9 of Table 1 of Article 1020.04 of the Standard Specifications to read:

“(9) The cement shall be a rapid hardening according to Article 1001.01(d). Minimum or maximum cement factor may be adjusted when approved by the Engineer.”

Revise the second paragraph of Article 1020.05(a) of the Standard Specifications to read:

“For a mix design using a portland-pozzolan cement, portland blast-furnace slag cement, portland-limestone cement, or replacing portland cement with finely divided minerals per Articles 1020.05(c) and 1020.05(d), the Contractor may submit a mix design with a minimum portland cement content less than 400 lbs/cu yd (237 kg/cu m), but not less than 375 lbs/cu yd (222 kg/cu m), if the mix design is shown to have a minimum relative dynamic modulus of elasticity of 80 percent determined according to AASHTO T 161. Testing shall be performed by an independent laboratory accredited by AASHTO re:source for Portland Cement Concrete.”

Revise the first sentence of the first paragraph of Article 1020.05(b) of the Standard Specifications to read:

“Corrosion inhibitors and concrete admixtures shall be according to the qualified product lists.”

Delete the fourth and fifth sentences of the second paragraph of Article 1020.05(b) of the Standard Specifications.

Revise Article 1020.05(b)(5) of the Standard Specifications to read:

“(5) For Class PP-4 concrete, a high range water-reducing admixture, retarder, and/or hydration stabilizer may be used in addition to the air-entraining admixture. The Contractor also has the option to use a water-reducing admixture with the high range water-reducing admixture. An accelerator shall not be used. A mobile portland cement concrete plant shall be used to produce the patching mixture.

For PP-5 concrete, a non-chloride accelerator, high range water-reducing admixture, retarder, hydration stabilizer, and/or air-entraining admixture may be used. The accelerator, high range water-reducing admixture, retarder, hydration stabilizer, and/or air-entraining admixture shall be per the Contractor’s recommendation and dosage. The qualified product list of concrete admixtures shall not apply. A mobile portland cement concrete plant shall be used to produce the patching mixture.”

Revise second paragraph of Article 1020.05(b)(10) of the Standard Specifications to read:

“When calcium nitrite is used, it shall be added at the rate of 4 gal/cu yd (20 L/cu m) and shall be added to the mix immediately after all compatible admixtures have been introduced to the batch. Other corrosion inhibitors shall be added per the manufacturer’s specifications.”

Delete the third paragraph of Article 1020.05(b)(10) of the Standard Specifications.

Revise Article 1020.15(b)(1)c. of the Standard Specifications to read:

“c. The minimum portland cement content in the mixture shall be 375 lbs/cu yd (222 kg/cu m). When the total of organic processing additions, inorganic processing additions, and limestone addition exceed 5.0 percent in the cement, the minimum portland cement content in the mixture shall be 400 lbs/cu yd (237 kg/cu m). For a drilled shaft, foundation, footing, or substructure, the minimum portland cement may be reduced to as low as 330 lbs/cu yd (196 kg/cu m) if the concrete has adequate freeze/thaw durability. The Contractor shall provide freeze/thaw test results according to AASHTO T 161, and the relative dynamic modulus of elasticity of the mix design shall be a minimum of 80 percent. Testing shall be performed by an independent laboratory accredited by AASHTO re:source for Portland Cement Concrete. Freeze/thaw testing will not be required for concrete that will not be exposed to freezing and thawing conditions as determined by the Engineer.”

Revise Article 1021.01 of the Standard Specifications to read:

**“1021.01 General.** Admixtures shall be furnished in liquid or powder form ready for use. The admixtures shall be delivered in the manufacturer's original containers, bulk tank trucks or such containers or tanks as are acceptable to the Engineer. Delivery shall be accompanied by a ticket which clearly identifies the manufacturer, the date of manufacture, and trade name of the material. Containers shall be readily identifiable as to manufacturer, the date of manufacture, and trade name of the material they contain.

Concrete admixtures shall be on one of the Department's qualified product lists. Unless otherwise noted, admixtures shall have successfully completed and remain current with the AASHTO Product Eval and Audit Concrete Admixture (CADD) testing program. For admixture submittals to the Department; the product brand name, manufacturer name, admixture type or types, an electronic link to the product's technical data sheet, and the NTPEP testing number which contains an electronic link to all test data shall be provided. In addition, a letter shall be submitted certifying that no changes have been made in the formulation of the material since the most current round of tests conducted by AASHTO Product Eval and Audit. After 28 days of testing by AASHTO Product Eval and Audit, air-entraining admixtures may be provisionally approved and used on Departmental projects. For all other admixtures, unless otherwise noted, the time period after which provisionally approved status may be earned is 6 months.

The manufacturer shall include the following in the submittal to the AASHTO Product Eval and Audit CADD testing program: the manufacturing range for specific gravity, the midpoint and manufacturing range for residue by oven drying, and manufacturing range of pH. The submittal shall also include an infrared spectrophotometer trace no more than five years old.

For air-entraining admixtures according to Article 1021.02, the specific gravity allowable manufacturing range established by the manufacturer shall be according to AASHTO M 194. For residue by oven drying and pH, the allowable manufacturing range and test methods shall be according to AASHTO M 194.

For admixtures according to Articles 1021.03, 1021.04, 1021.05, 1021.06, 1021.07, and 1021.08, the pH allowable manufacturing range established by the manufacturer shall be according to ASTM E 70. For specific gravity and residue by oven drying, the allowable manufacturing range and test methods shall be according to AASHTO M 194.

All admixtures, except chloride-based accelerators, shall contain a maximum of 0.3 percent chloride by weight (mass) as determined by an appropriate test method. To verify the test result, the Department will use Illinois Modified AASHTO T 260, Procedure A, Method 1.

Prior to final approval of an admixture, the Engineer reserves the right to request a sample for testing. The test and reference concrete mixtures tested by the Engineer will contain a cement content of 5.65 cwt/cu yd (335 kg/cu m). For freeze-thaw testing, the Department will perform the test according to Illinois Modified AASHTO T 161. The flexural strength test will be performed according to AASHTO T 177. If the Engineer decides to test the admixture, the manufacturer shall submit AASHTO T 197 water content and set time test results on the standard cement used by the Department. The manufacturer may select their lab or an independent lab to perform this testing. The laboratory is not required to be accredited by AASHTO.

Random field samples may be taken by the Department to verify an admixture meets specification. A split sample will be provided to the manufacturer if requested. Admixtures that do not meet specification requirements or an allowable manufacturing range established by the manufacturer shall be replaced with new material.”

Revise Article 1021.03 of the Standard Specifications to read:

“**1021.03 Retarding and Water-Reducing Admixtures.** The admixture shall be according to the following.

- (a) Retarding admixtures shall be according to AASHTO M 194, Type B (retarding) or Type D (water-reducing and retarding).
- (b) Water-reducing admixtures shall be according to AASHTO M 194, Type A.
- (c) High range water-reducing admixtures shall be according to AASHTO M 194, Type F (high range water-reducing) or Type G (high range water-reducing and retarding).”

Revise Article 1021.05 of the Standard Specifications to read:

“**1021.05 Self-Consolidating Admixtures.** Self-consolidating admixture systems shall consist of either a high range water-reducing admixture only or a high range water-reducing admixture combined with a separate viscosity modifying admixture. The one or two component admixture system shall be capable of producing a concrete that can flow around reinforcement and consolidate under its own weight without additional effort and without segregation.

High range water-reducing admixtures shall be according to AASHTO M 194, Type F.

Viscosity modifying admixtures shall be according to AASHTO M 194, Type S (specific performance).”

Revise Article 1021.06 of the Standard Specifications to read:

“**1021.06 Rheology-Controlling Admixture.** Rheology-controlling admixtures shall be capable of producing a concrete mixture with a lower yield stress that will consolidate easier for slipform applications used by the Contractor. Rheology-controlling admixtures shall be according to AASHTO M 194, Type S (specific performance).”

Revise Article 1021.07 of the Standard Specifications to read:

“**1021.07 Corrosion Inhibitor.** The corrosion inhibitor shall be according to one of the following.

- (a) Calcium Nitrite. Corrosion inhibitors shall contain a minimum 30 percent calcium nitrite by weight (mass) of solution and shall comply with either the requirements of AASHTO

M 194, Type C (accelerating) or the requirements of ASTM C 1582. The corrosion inhibiting performance requirements of ASTM C 1582 shall not apply.

(b) Other Materials. The corrosion inhibitor shall be according to ASTM C 1582.

For submittals requiring testing according to ASTM M 194, Type C (accelerating), the admixture shall meet the requirements of the AASHTO Product Eval and Audit CADD testing program according to Article 1021.01.

For submittals requiring testing according to ASTM C 1582, a report prepared by an independent laboratory accredited by AASHTO re:source for portland cement concrete shall be provided. The report shall show the results of physical tests conducted no more than five years prior to the time of submittal, according to applicable specifications. However, ASTM G 109 test information specified in ASTM C 1582 is not required to be from an independent accredited lab. All other information in ASTM C 1582 shall be from an independent accredited lab. Test data and other information required to be submitted to AASHTO Product Eval and Audit according to Article 1021.01, shall instead be submitted directly to the Department.”

Add Article 1021.08 of the Standard Specifications as follows:

“**1021.08 Other Specific Performance Admixtures.** Other specific performance admixtures shall, at a minimum, be according to AASHTO M 194, Type S (specific performance). The Department also reserves the right to require other testing, as determined by the Engineer, to show evidence of specific performance characteristics.

Initial testing according to AASHTO M 194 may be conducted under the AASHTO Product Eval and Audit CADD testing program according to Article 1021.01, or by an independent laboratory accredited by AASHTO re:source for Portland Cement Concrete. In either case, test data and other information required to be submitted to AASHTO Product Eval and Audit according to Article 1021.01, shall also be submitted directly to the Department. The independent accredited lab report shall show the results of physical tests conducted no more than five years prior to the time of submittal, according to applicable specifications.”

Add Article 1021.09 of the Standard Specifications as follows:

“**1021.09 Latex Admixtures.** The latex admixture shall be a uniform, homogeneous, non-toxic, film-forming, polymeric emulsion in water to which all stabilizers have been added at the point of manufacture. The latex admixture shall not contain any chlorides and shall contain 46-49 percent solids.

In lieu of meeting the requirements of Article 1021.01, the Contractor shall submit a manufacturer's certification that the latex emulsion meets the requirements of FHWA Research Report RD-78-35, Chapter VI. The certificate shall include the date of manufacture of the latex admixture, batch or lot number, quantity represented, manufacturer's name, and the location of the manufacturing plant. The latex emulsion shall be sampled and tested in accordance with RD-78-35, Chapter VII, Certification Program.

The latex admixture shall be packaged and stored in containers and storage facilities which will protect the material from freezing and from temperatures above 85°F (30°C). Additionally, the material shall not be stored in direct sunlight and shall be shaded when stored outside of buildings during moderate temperatures.”

Revise Article 1024.01 of the Standard Specifications to read:

“**1024.01 Requirements for Grout.** The grout shall be proportioned by dry volume, thoroughly mixed, and shall have a minimum temperature of 50 °F (10 °C). Water shall not exceed the minimum needed for placement and finishing.

Materials for the grout shall be according to the following.

Item	Article/Section
(a) Cement .....	1001
(b) Water .....	1002
(c) Fine Aggregate .....	1003.02
(d) Fly Ash .....	1010
(e) Ground Granulated Blast Furnace (GGBF) Slag.....	1010
(f) Concrete Admixtures .....	1021”

Revise Note 1 of Article 1024.02 of the Standard Specifications to read:

“Note 1. Nonshrink grout shall be according to ASTM C 1107.

For prestressed concrete applications, the nonshrink grout shall have a water soluble chloride ion content of less than 0.06 percent by weight of cementitious material when tested according to ASTM C 1218 or AASHTO T 260; and for non-prestressed concrete applications, the water soluble chloride ion content shall be less than 0.15 percent by weight of cementitious material. The testing according to ASTM 1107, and either ASTM C 1218 or AASHTO T 260 shall be performed by an independent lab a minimum of once every five years, and the test results shall be provided to the Department. The Department will maintain a qualified product list. Mixing of the nonshrink grout shall be according to the manufacturer’s specifications.”

Revise Article 1029.02 of the Standard Specifications to read:

“**1029.02 Materials.** Materials shall be according to the following.

Item	Article/Section
(a) Cement.....	1001
(b) Fly Ash .....	1010
(c) Ground Granulated Blast Furnace (GGBF) Slag .....	1010
(d) Water.....	1002
(e) Fine Aggregate.....	1003
(f) Concrete Admixtures .....	1021

(g) Foaming Agent (Note 1)

Note 1. The manufacturer shall submit infrared spectrophotometer trace and test results indicating the foaming agent meets the requirements of ASTM C 869 in order to be on the Department's qualified product list. Submitted data/results shall not be more than five years old."

Revise the second paragraph of Article 1103.03(a)(4) the Standard Specifications to read:

"The dispenser system shall provide a visual indication that the liquid admixture is actually entering the batch, such as via a transparent or translucent section of tubing or by independent check with an integrated secondary metering device. If approved by the Engineer, an alternate indicator may be used for admixtures dosed at rates of 25 oz/cwt (1630 mL/100 kg) or greater, such as accelerating admixtures, corrosion inhibitors, and viscosity modifying admixtures."

Revise Article 1103.04 of the Standard Specifications to read:

**"1103.04 Mobile Portland Cement Concrete Plants.** The mobile concrete plant shall be according to AASHTO M 241 and the Bureau of Materials Policy Memorandum "Approval of Volumetric Mobile Mixers for Concrete". The mixer shall be capable of carrying sufficient unmixed materials to produce not less than 6 cu yd (4.6 cu m) of concrete."

Revise the first two sections of Check Sheet #11 "Subsealing of Concrete Pavements" of the Recurring Special Provisions to read:

"Description. This work shall consist of filling voids beneath rigid and composite pavements with cement grout.

Materials. Materials shall be according to the following Articles/Sections of the Standard Specifications:

Item	Article/Section
(a) Cement .....	1001
(b) Water .....	1002
(c) Fly Ash .....	1010
(d) Ground Granulated Blast Furnace (GGBF) Slag.....	1010
(e) Admixtures .....	1021
(f) Packaged Rapid Hardening Mortar or Concrete .....	1018"

Revise the Materials section of Check Sheet #28 "Portland Cement Concrete Inlay or Overlay" of the Recurring Special Provisions to read:

"Materials. Materials shall be according to the following Articles/Sections of the Standard Specifications.

Item	Article/Section
(a) Portland Cement Concrete (Note 1) .....	1020
(b) Fibers for Concrete.....	1014
(c) Protective Coat.....	1023.01

Note 1. Class PV concrete shall be used, except the cement factor for central mixed concrete shall be 6.05 cwt/cu yd (360 kg/cu m). A cement factor reduction according to Article 1020.05(b)(8) of the Standard Specifications will be permitted. CA 5 shall not be used and CA 7 may only be used for overlays that are a minimum of 4.5 in. (113 mm) thick. The Class PV concrete shall have a minimum flexural strength of 550 psi (3800 kPa) or a minimum compressive strength of 3000 psi (20,700 kPa) at 14 days.”

80460

## **CONCRETE BARRIER (BDE)**

Effective: January 1, 2025

Revise the second paragraph of Article 637.12 of the Standard Specifications to read:

“When a double face concrete barrier with a variable cross-section is required, and the variation exceeds 1/2 in. (13 mm), the barrier will be paid for at the contract unit price per foot (meter) for CONCRETE BARRIER, VARIABLE CROSS-SECTION, of the height specified.”

80461

## **SIGN PANELS AND APPURTENANCES (BDE)**

Effective: January 1, 2025

Revised: January 1, 2026

Add Article 720.02(c) of the Standard Specifications to read:

“(c) Aluminum Epoxy Mastic .....1008.03”

Revise the second and third paragraphs of Article 720.02 of the Standard Specifications to read:

“The sign mounting support channel shall be manufactured from steel or aluminum and shall be according to Standard 720001.

Steel support channels shall be according to ASTM A 1011 (A 1011M), ASTM A 635 (A 635M), ASTM A 568 (A 568M), or ASTM A 684 (A 684M), and shall be galvanized. Galvanizing shall be according to ASTM A 653 (A 653M) when galvanized before fabrication, and AASHTO M 111 (M 111M) when galvanized after fabrication. Field or post fabricated drilled holes shall be spot painted with one coat of aluminum epoxy mastic paint prior to installation.”

Revise the fifth paragraph of Article 720.02 of the Standard Specifications to read:

“The stainless steel banding for mounting signs or sign support channels to light or signal standards shall be according to ASTM A 240 (A 240M) Type 302 stainless steel.”

Revise the first sentence of the tenth paragraph of Article 720.03 of the Standard Specifications to read:

“The backs of all sign panels shall be marked in a manner designed to last as long as the sign face material, in letters and numerals at least 3/8 in. (9.5 mm) but no more than 3/4 in. (19 mm) in height with the month and year of manufacture, the name of the sign manufacturer, the name of the sign sheeting manufacturer, the method of manufacture (“screened”, “EC film”, “direct applied”, or “digital print”), and the initials IDOT.”

Revise the first sentence of the fourth paragraph of Article 1091.03(a)(10) of the Standard Specifications to read:

“Transparent colors screened, or transparent acrylic electronic cutting films, or digital printing on white sheeting, shall meet the minimum initial coefficient of retroreflection values of the 0.2 degree observation angle, -4.0 degree entrance angle values as listed in the previous tables for the color being applied.”

Add the following after the fourth paragraph of Article 1091.03(a)(10) of the Standard Specifications:

“Digitally printed signs shall be produced using digital print technologies and ink systems, products and processes that comply with the sheeting manufacturer’s recommendation. The digitally printed signs shall be fabricated with a full sign protective overlay film designed to provide a smooth surface needed for retroreflectivity, and to protect the sign from fading and UV degradation. The overlamine shall comply with the sheeting manufacturer’s recommendations to ensure proper adhesion and transparency.”

Add the following after the third paragraph of Article 1106.01 of the Standard Specifications:

“Digitally printed signs may omit protective overlay film.”

80462

## **SUBMISSION OF BIDDERS LIST INFORMATION (BDE)**

Effective: January 2, 2025

Revised: March 2, 2025

In accordance with 49 CFR 26.11(c) all DBE and non-DBEs who bid as prime contractors and subcontractors shall provide bidders list information, including all DBE and non-DBE firms from whom the bidder has received a quote or bid to work as a subcontractor, whether or not the bidder has relied upon that bid in placing its bid as the prime contractor.

The bidders list information shall be submitted with the bid using the link provided within the “Integrated Contractor Exchange (iCX)” application of the Department’s “EBids System”.

80463

## **PAVEMENT MARKING (BDE)**

Effective: April 1, 2025

Revised: November 1, 2025

Revise the fourth sentence of the fourth paragraph of Article 780.05 of the Standard Specifications to read:

“Grooves for letters and symbols shall be cut in a rectangular shape or in the shape of the proposed marking so the entire marking will fit within the limits of the grooved area.”

Revise the last sentence of the third paragraph of Article 780.08 of the Standard Specifications to read:

“The Contractor shall install the preformed plastic pavement markings according to the manufacturer’s recommendations.”

Revise the second sentence of the first paragraph of Article 780.13 of the Standard Specifications to read:

“In addition, thermoplastic, preformed plastic, epoxy, preformed thermoplastic, polyurea, and modified urethane pavement markings will be inspected following a winter performance period that extends from November 15 to April 1 of the next year.”

80464

**SURVEYING SERVICES (BDE)**

Effective: April 1, 2025

Delete the fourth paragraph of Article 667.04 of the Standard Specifications.

Delete Section 668 of the Standard Specifications.

80465

## TEMPORARY RUMBLE STRIPS (BDE)

Effective: April 1, 2025

Revise Article 701.15(k) of the Standard Specifications to read:

“(k) Temporary Rumble Strips. Temporary rumble strips provide an audible and tactile warning to alert motorists of an approaching work zone or change in driving pattern or highway condition. The number and spacing of temporary rumble strips installed per set shall be as shown in Standard 701901. Temporary rumble strips shall be applied to the pavement according to the manufacturer’s recommendations.

Breakage or significant permanent deformation of the strip shall constitute failure. Compaction or slipping of material that reduces the effectiveness of the audible or vibration warnings shall constitute failure.

Upon completion of the project, or as directed by the Engineer, temporary rumble strips shall be entirely removed using a method that does not permanently damage the pavement surface.”

Revise Article 701.19(e) of the Standard Specifications to read:

“(e) Temporary rumble strips will be measured as each, where each is defined as a set of six temporary rumble strips across a single lane of pavement, and each set of temporary rumble strips will be measured for payment once per location.”

Revise Article 1106.03 of the Standard Specifications to read:

“**1106.03 Temporary Rumble Strips.** Temporary rumble strips shall be black or white. Temporary rumble strips shall be constructed of a flexible, pliant, impact-resistant material capable of supporting a load of 6000 lb (2700 kg). Temporary rumble strips shall be 1/4 in. (6 mm) to 1 in. (25 mm) thick and 4 in. (100 mm) to 6 in. (150 mm) wide. Temporary rumble strips shall be weather resistant and, through normal traffic wear, show no appreciable fading, lifting, tearing, rollback, or other signs of poor adhesion.”

80466

## **EROSION CONTROL BLANKET (BDE)**

Effective: August 1, 2025

Revise Article 251.02 of the Standard Specifications to read:

**“251.02 Materials.** Materials shall be according to the following.

Item	Article/Section
(a) Compost .....	1081.05(b)
(b) Mulch .....	1081.06(a)
(c) Chemical Mulch Binder .....	1081.06(a)(3)
(d) Chemical Compost Binder .....	1081.06(a)(4)
(e) Erosion Control Blanket .....	1081.10(a)
(f) Wildlife Friendly Erosion Control Blanket .....	1081.10(b)
(g) Wire Staples.....	1081.10(c)
(h) Wood Stakes .....	1081.10(d)
(i) Turf Reinforcement Mat .....	1081.10(e)”

Revise the first and second sentences of Article 251.04 of the Standard Specifications to read:

**“251.04 Erosion Control Blanket.** All erosion control blanket materials shall be placed on the areas specified within 24 hours of seed placement.”

Revise the second paragraph of Article 251.04 of the Standard Specifications to read:

“After the area has been properly shaped, fertilized (when applicable), and seeded, the blanket shall be laid out flat, evenly, and smoothly, without stretching the material. The erosion control blanket shall be placed according to the manufacture’s recommendations.”

Revise the second sentence of Article 251.06(b) of the Standard Specifications to read:

“Erosion control blanket, wildlife friendly erosion control blanket, and turf reinforcement mat will be measured for payment in square yards (square meters).”

Revise Article 251.07 of the Standard Specifications to read:

**“251.07 Basis of Payment.** This work will be paid for at the contract unit price per acre (hectare) for MULCH, of the method specified; and at the contract unit price per square yard (square meter) for EROSION CONTROL BLANKET, WILDLIFE FRIENDLY EROSION CONTROL BLANKET, or TURF REINFORCEMENT MAT.”

Revise first sentence of Article 280.04(h) of the Standard Specifications to read:

“This system consists of temporarily installing erosion control blanket or wildlife friendly erosion control blanket over areas that are to be reworked during a later construction phase.”

Revise Article 280.08(g) of the Standard Specifications to read:

“(g) Temporary Erosion Control Blanket. Temporary erosion control blanket will be paid for at the contract unit price per square yard (square meter) for TEMPORARY EROSION CONTROL BLANKET or TEMPORARY WILDLIFE FRIENDLY EROSION CONTROL BLANKET.

The work of removing, storing, and reinstalling the blanket over areas to be reworked more than once will not be paid for separately but shall be included in the cost of the temporary erosion control blanket or temporary wildlife friendly erosion control blanket.”

Revise Article 1081.10 of the Standard Specifications to read:

“**1081.10 Erosion Control Blankets.** The manufacturer shall furnish a certificate with each shipment stating the amount of product furnished and that the material complies with these requirements.

(a) Erosion Control Blanket. Erosion control blanket shall be covered on top and bottom, also known as double net, with a 100 percent biodegradable woven, natural fiber or jute net meeting the following.

Material	Minimum Value
Excelsior	80%
Straw	100%
Coconut or Coir	100% Coconut or Coir
Straw/Coconut or Coir	70% Straw / 30% Coconut or Coir

(b) Wildlife Friendly Erosion Control Blanket. Wildlife friendly erosion control blanket shall be according to Article 1081.10(a) except the netting shall be loose weave, also known as leno weave or gauze weave, with a moveable joint.

(c) Wire Staples. Staples shall be made from No. 11 gauge or heavier uncoated black carbon steel wire, a minimum of 1 in. (25 mm) wide at the top and a minimum overall length of 8 in. (200 mm).

(d) Wood Stakes. Hardwood blanket anchors shall be nominally 7 in. (180 mm) long from neck of hook to tip of anchor. The anchor shall have a minimum 1/2 in. (13 mm) curving hook to hold the blanket in place.

(e) Turf Reinforcement Mat (TRM). The TRM shall be comprised of non-degradable, ultraviolet stabilized synthetic fibers, filaments, netting, and/or wire mesh processed into

a three-dimensional reinforced mat. The mats may include degradable material to assist with vegetation establishment. Soil filled mats will not be allowed.

The TRM shall meet the following physical and performance properties:

Property	Value	Test Method
Tensile Strength, lb/ft (kN/m)	150 (2.19) min.	ASTM D 6818
UV Stability, (% Tensile Retained)	80 min.	ASTM D 4355 (1000 Hour Exposure)
Resiliency, (% Thickness Retained)	80 min.	ASTM D 6524
Allowable Shear Stress, lb/sq ft (Pa) <sup>1/</sup>	8 (384)	ECTC approved test method and independent laboratory

1/ Minimum shear stress the TRM (fully vegetated) can sustain without physical damage or excess erosion (> 1/2 in. (13 mm) soil loss) during a 30 minute flow event in large scale testing.

For TRMs containing degradable components, all property values shall be obtained on the non-degradable portion of the matting alone.”

## **PAVEMENT PATCHING (BDE)**

Effective: August 1, 2025

Revise the first sentence of the last paragraph of Article 442.06(a)(2) of the Standard Specifications to read:

“Type IV patches shall be reinforced with welded wire reinforcement according to the details shown on the plans.”

Revise Article 442.06(a)(3) of the Standard Specifications to read:

“(3) Class C Patching. Patches adjacent to a new lane of pavement, new portland cement concrete shoulder, or new curb and gutter of more than 20 ft (6 m) in length shall be tied with No. 6 (No. 19) tie bars, 24 in. (600 mm) long, embedded 8 in. (200 mm) at 36 in. (900 mm) centers according to Article 420.05(b).

When the patched pavement is not to be resurfaced, transverse contraction joints shall be formed on 15 ft (4.5 m) to 20 ft (6 m) centers by sawing in all patches that are more than 20 ft (6 m) in length. They shall be placed in line with joints or cracks in the existing slab whenever possible.”

Revise the eighth paragraph of Article 442.11 of the Standard Specifications to read:

“Pavement tie bars for patches will be paid for at the contract unit price per each for TIE BARS, of the diameter specified.”

80468

**SLOPE WALL (BDE)**

Effective: August 1, 2025

Revise Article 511.02(b) of the Standard Specifications to read:

“(b) Welded Wire Reinforcement (Note 3) ..... 1006.10”

Add the following note to the end of Article 511.02 of the Standard Specifications.

“Note 3. Welded wire reinforcement used for concrete slope wall shall be epoxy coated or galvanized according to AASHTO M 111 (M 111M).”

Revise the second sentence of Article 511.03(a) of the Standard Specifications to read:

“Concrete slope walls shall be reinforced with welded wire reinforcement consisting of 6 x 6 in. (150 x 150 mm) mesh, #4 gauge (5.74 mm), 58 lb (26 kg) per 100 sq ft (9 sq m) and supported 2 in. (50 mm) below the upper surface of the slope wall by concrete blocks.”

Add the following to the end of Article 511.03(a) of the Standard Specifications as the last paragraph.

“The concrete slope wall shall be given a broom finish. The broom shall be drawn vertically along the slope wall surface, with adjacent strokes slightly overlapping, producing a uniform, slightly rough surface with parallel broom marks.”

## **TRAFFIC SIGNAL BACKPLATE (BDE)**

Effective: August 1, 2025

Revise the second sentence of the third paragraph of Article 1078.03 of the Standard Specifications to read:

“Retroreflective sheeting shall be Type AZ or Type ZZ according to Article 1091.03 and applied in the preferred orientation for the maximum angularity according to the manufacturer’s recommendations.”

80470

## **GUARDRAIL (BDE)**

Effective: November 1, 2025

Revise Article 701.17(f) of the Standard Specifications to read:

- “(f) Guardrail. Where guardrail is temporarily removed or where the guardrail installation is incomplete, Type II barricades or drums shall be placed at 50 ft (15 m) centers during completion of the work.

Guardrail installation shall be completed within three calendar days of removal or shielded with a temporary longitudinal traffic barrier approved by the Engineer.

On staged construction projects all guardrail and end terminal installations shall be complete prior to switching traffic.”

80471

## HIGH FRICTION SURFACE TREATMENT (BDE)

Effective: November 1, 2025

Add the following Section to the Standard Specifications:

### “SECTION 409. HIGH FRICTION SURFACE TREATMENT

**409.01 Description.** This work shall consist of constructing a high friction surface treatment (HFST) on an existing hot-mix asphalt (HMA) or portland cement concrete (PCC) pavement surface.

**409.02 Materials.** Materials shall be according to the following.

Item	Article/Section
(a) Epoxy Resin Binder .....	1034
(b) Coarse Aggregate .....	1004.08

**409.03 Equipment.** Equipment shall be according to the following.

Item	Article/Section
(a) HFST Application Machine .....	1101.21
(b) Air Compressor .....	1101.19
(c) Regenerative Air Vacuum Sweeper .....	1101.22

### CONSTRUCTION REQUIREMENTS

**409.04 General.** The HFST shall be placed by a qualified applicator according to the Department’s qualified product list.

**409.05 Weather Limitations.** The epoxy resin binder shall be applied to a dry surface when no rain has occurred for 24 hours prior to application and the ambient air temperature is a minimum of 55 °F (13 °C), unless the epoxy resin manufacturer can provide test data to support installations at lower temperatures, to a maximum of 105 °F (40 °C) or when the anticipated weather conditions or pavement surface temperature would prevent the proper application of the surface treatment according to the manufacturer’s recommendations.

The HFST shall only be applied if the surface moisture content is 4.5 percent or less when measured on a 20 ft (6 m) spacing throughout the application area using a calibrated electronic moisture meter.

**409.06 Quality Control (QC) Plan.** The Contractor shall submit a QC Plan to the Engineer for approval at least 30 days before placement. The QC Plan requirements shall be discussed at the pre-construction, pre-pave, and progress meetings, and contain, at a minimum, the following.

- (a) Key personnel and contact information, including the QC Manager.
- (b) Equipment which will be used.
- (c) Epoxy resin production plant.
- (d) Aggregate production plant.
- (e) Moisture control methods for aggregate.
- (f) Provide the electronic moisture meter manufacturer's calibration documents and method of conducting periodic accuracy checks. Provide a procedure for measuring moisture on the pavement before HFST installation. Provide a procedure for corrective action if the moisture meter results fall outside of the acceptable range.
- (g) List of manufacturer recommendations for storage of material, weather restrictions, epoxy resin blending procedures, curing time to begin sweeping operations and opening to traffic.
- (h) Plan for monitoring and recording ambient conditions (air temperature, surface temperature, and relative humidity).
- (i) Cleaning and maintenance schedule for truck-mounted application machines, including metering and monitoring devices.
- (j) Traffic plan for ingress and egress for all material handling operations.

The QC Manager and a field technician shall be on the job site at all times during the placement of the HFST.

The field technician shall be responsible for the required field quality control sampling and testing. All sampling shall be performed in the presence of and in locations as directed by the Engineer. Maintain and make available upon request complete records of sampling, testing, actions taken to correct problems, and quality control inspection results.

**409.07 Test Strip.** A 200 sq yd (168 sq m) test strip shall be required for contracts with a quantity of 1,000 sq yd (836 sq m) or more of HFST to demonstrate the truck-mounted application machine has been properly calibrated. The Engineer will evaluate the application rate and cure time.

**409.08 Surface Preparation.** The surface shall be free of dust, dirt, oil, grease, paint, and all foreign matter. Pressure washing some areas may be necessary. Mild detergents may be used in pressure washing procedures when allowed by the manufacturer. Completely dry the area to be overlaid using compressed air or hot compressed air.

Pavement patching shall be performed in accordance with Section 442.

Joints and cracks 3/8 in. (10 mm) or wider shall be cleaned of vegetation, loose and unsound material and filled with a sealant recommended by the epoxy resin manufacturer that will bond to the specified epoxy resin binder. The cleaned cracks shall be filled such that the sealant is flush with the pavement surface.

Cover and protect all utilities, preformed joint seal, raised pavement markers, and existing pavement markings in areas where markings will be left in place.

**409.09 HFST Application.** HFST shall be applied not less than 30 days after placement of new HMA or new PCC surface or patches. The surface shall be clean, dry, and free of dust, oil, debris, and any foreign matter that might interfere with the bond between the epoxy resin binder material and existing surfaces. Shot blast all PCC surfaces. The blasted surface shall conform to the International Concrete Repair Institute, ICRI, Guideline No. 310.2 for surface roughness concrete surface profile of CSP 5. After shot blasting, remove dust, debris, and deleterious material by vacuuming, sweeping, and air washing, with a minimum of 180 cu ft/min (5 cu m/min) of clean and dry compressed air. Maintain the air lance perpendicular to the surface and the tip of the air lance within 12 in. (300 mm) of the surface. Install HFST within the same working day as the completed air wash.

- (a) Projects Greater Than or Equal to 300 sq yd (250 sq m). The epoxy resin binder and aggregate shall be applied by a HFST application machine in a single pass on projects with a total HFST quantity of at least 300 sq yd (250 sq m). The binder shall be mixed per the manufacturer's recommendations and applied at a uniform rate with a uniform thickness of 55-65 mils (1.4-1.7 mm). The aggregate shall be applied at a uniform rate to ensure complete coverage of the "wet" epoxy resin binder.

The binder shall not be allowed to separate in the mixing lines, cure, dry, chill, set up, or otherwise impair retention bonding to the aggregate. The Contractor shall ensure that no seams are visible in the middle of the traffic lanes of the finished work.

- (b) Projects Less Than 300 sq yd (250 sq m). HFST application machine according to Article 409.09(a) or manual application shall be used on projects with a total HFST quantity less than 300 sq yd (250 sq m).

For manual application, the binder shall be mixed to the manufacturers recommended proportion within 4 percent by weight using a low-speed high torque drill fitted with a helical stirrer and applied manually at a uniform rate with a uniform thickness of 55-65 mils (1.4-1.7 mm) using a serrated edged squeegee.

The aggregate shall be applied immediately and uniformly across the treated area without displacing the wet epoxy resin film, whether by mechanical or manual means to ensure complete coverage. Additional aggregate shall be applied to any remaining "wet" areas to ensure complete coverage of the epoxy resin binder.

The Contractor shall not compact or force embedment of the aggregate after placement.

**409.10 Curing and Clean Up.** Allow the treatment to cure following epoxy resin manufacturer recommendations. Perform three separate clean-up processes by removing the excess aggregate with a regenerative air vacuum sweeper on the treated area and adjacent areas. Perform initial clean-up before opening to traffic. Excess aggregate may be reused on the following day's installation provided the aggregate is clean, uncontaminated, and dry. Perform secondary clean-up 3 to 5 days after construction. Perform final clean-up 3 to 5 weeks after construction. No loose aggregate shall remain after final clean-up.

**409.11 Sampling and Testing.** During the first day of placing HFST, 0.125 gal (0.5 L) samples of each component of the epoxy resin binder and two 40 lb (18 kg) sample bags of aggregate shall be submitted to the Department. The Contractor shall supply and label the samples under observation of the Engineer.

The finished HFST will be tested by the Department within 60 days after construction and shall meet the following requirements.

Field Acceptance Testing Requirements			
Property	Requirements	Frequency	Test Method
FN40R OPTIONAL	72 min.	Every 0.1 mile in each lane.	ASTM E 274 (Ribbed tire)
Mean Profile Depth (mm) OPTIONAL	1.0 min.	1 per each location, or 1 per every 1,500 lane-feet, whichever is shorter.	ASTM E 2157

**409.12 Method of Measurement.** High friction surface treatment will be measured for payment in square yards (sq m).

Pavement patching will be measured for payment according to Article 442.10.

Pavement marking removal will be measured for payment according to Article 783.05.

Crack/joint filling will be measured for payment in feet (meters), measured along the crack.

**409.13 Basis of Payment.** High friction surface treatment will be paid for at the contract unit price per square yard (square meter) for HIGH FRICTION SURFACE TREATMENT.

Pavement patching will be paid according to Article 442.11.

Pavement marking removal will be paid according to Article 783.06.

Crack/joint filling will be paid for at the contract unit price per foot (meter) for HIGH FRICTION SURFACE TREATMENT CRACK FILLING.”

Add the following Article to the Standard Specifications:

**“1004.08 Coarse Aggregate for High Friction Surface Treatment.** The aggregate shall be calcined bauxite that is clean, dry, free from foreign matter, non-friable, non-polishing, durable and conforms to the requirements of AASHTO M 354, Table 4. Calcined bauxite shall be delivered to the construction site in clearly labeled packaging that protects the aggregate from any contaminants on the job site and exposure to rain or other moisture. All packages shall be labeled with the supplier, the manufacturer or source name, and the location of processing. The aggregate shall be on the Department’s qualified product list “High Friction Surface Treatment”.

Safety data sheets, technical data sheets, and other information about the safe practices for the storage, handling, and disposal of the materials, and their health hazards shall be obtained from the manufacturer and posted in storage areas. A copy of such information shall be provided to the Engineer.”

Add the following Section to the Standard Specifications:

#### **“SECTION 1034 EPOXY RESIN BINDER**

**1034.01 Epoxy Resin Binder.** The binder shall consist of a two-part exothermic epoxy resin which conforms to the requirements of AASHTO M 354, Table 1. The epoxy resin shall be packaged in sealed containers, labeled with the type of material and the ratio of components to be mixed by volume. Each packaged component shall display the type (resin or hardener), brand name, name of the manufacturer, lot number, temperature range for storage, expiration date, and quantity. Each container shall be labeled with the appropriate caution warnings regarding contact with the component. The epoxy resin binder shall be on the Department’s qualified product list “High Friction Surface Treatment”.

Safety data sheets, technical data sheets, and other information about the safe practices for the storage, handling, and disposal of the materials, and their health hazards shall be obtained from the manufacturer and posted in storage areas. A copy of such information shall be provided to the Engineer.”

Add the following Article to the Standard Specifications:

**“1101.21 HFST Application Machine.** The HFST application machine shall be a self-propelled, fully or semi-automated truck-mounted applicator machine capable of continuously mixing and applying resin and aggregate at a uniform thickness and rate in varying widths of up to 12 ft (3.6 m). Equipment shall be calibrated according to the manufacturer’s recommendations. The quantity of all components shall be metered, controlled, and verifiable.

The aggregate shall be applied by a drop spreader capable of mechanically, continuously, and uniformly spreading bauxite aggregate. The aggregate spreader shall meet the requirements of the epoxy resin binder manufacturer.”

Add the following Article to the Standard Specifications:

**“1101.22 Regenerative Air Vacuum Sweeper.** The regenerative air vacuum sweeper shall be self-propelled with power brooms capable of cleaning the existing pavement and removing loose aggregate without dislodging the bonded aggregate. The regenerative air vacuum sweeper shall blast re-circulated, filtered air through a vacuum head having a minimum width of 6 ft (1.8 m) at a minimum rate of 20,000 cu ft/min (560 cu m/min). The regenerative air vacuum sweeper shall be capable of recycling loose aggregate into clean, uncontaminated, and dry aggregate. The regenerative air vacuum sweeper shall be capable of being used without water for dust suppression to ensure a dry surface will be maintained.”

80472

## **RAISED REFLECTIVE PAVEMENT MARKERS (BDE)**

Effective: November 1, 2025

Revise the eighth sentence of the second paragraph of Article 781.03(a) of the Standard Specifications to read:

“A rapid setting epoxy selected from the Department’s qualified product list for raised reflective pavement markers shall be poured into the cut to within 3/8 in. (9 mm) of the pavement surface.”

Revise the first sentence of Article 1096.01 of the Standard Specifications to read:

“**1096.01 Raised Reflective Pavement Markers.** Raised reflective pavement markers shall meet the following requirements and be on the Department’s qualified product list.”

80473

## RESIDENTIAL DRIVEWAY TEMPORARY SIGNAL (BDE)

Effective: November 1, 2025

Description. At the Contractor's option, residential driveway temporary signals (RDTS) may be used in place of temporary bridge traffic signals to control residential driveways within the one-lane two-way portion of the work zone. Work shall be according to Article 701.18(b), except as follows.

Materials. Materials shall be according to the following Articles/Sections of the Standard Specifications.

Item	Article/Section
(a) Light Emitting Diode (LED) Traffic Signal Head .....	1078

### CONSTRUCTION REQUIREMENTS

General. The RDTS shall be a self-contained mobile unit that includes a single vertical mast supporting a single three-section signal face comprising of a 12 in. (300 mm) diameter steady circular red indication on top and two adjacent 8 in. (200 mm) or 12 in. (300 mm) diameter flashing yellow arrow indications below. The device shall include a NO TURN ON RED sign (R10-11b) with a regulatory plaque displaying the legend TURN ONLY IN DIRECTION OF ARROW according to Attachments IA-23-2.1 and 2.2 of FHWA Memorandum "MUTCD – Interim Approval for Optional Use of Residential Driveway Temporary Signal (IA-23)".

The RDTS shall continuously operate using a self-contained power source over an ambient temperature range between -30 °F (-34 °C) and 120 °F (48 °C).

The RDTS shall be installed secure and level according to Attachment IA-23-1 of FHWA Memorandum "MUTCD – Interim Approval for Optional Use of Residential Driveway Temporary Signal (IA-23)".

The RDTS shall be coordinated, and have the capability to communicate, with the temporary bridge traffic signal system controlling main roadway traffic. During each green interval of the main roadway, the RDTS shall display a flashing yellow arrow indication corresponding to the direction of the main roadway traffic movement. A steady yellow change interval shall follow the flashing yellow arrow interval for the RDTS. The system shall be programmed such that driveway vehicles can turn before, within, and after the main roadway traffic platoon. The all-red interval of the temporary traffic signal shall be programmed to account for the addition of driveway vehicles to the platoon.

The entire traffic signal system including RDTS units shall be equipped with a malfunction management system that can communicate with all signal units. In the event of any fault at any signal unit including but not limited to loss of communication or display of conflicting signal indications, the entire system shall be placed in flashing mode. RDTS units shall flash red when operating in flashing mode.

The RDTS and temporary traffic signal system shall be verified to function properly before closing any lanes.

When not utilized to direct traffic, the RDTS shall be treated as non-operating equipment according to Article 701.11.

Basis of Payment. This work will not be paid for separately but shall be included in the cost of temporary bridge traffic signals according to Article 701.20(c).

80474

**BRIDGE DECK CONCRETE OVERLAYS**

Effective: January 1, 2026

Add the following Section 531 to the Standard Specifications:

**“SECTION 531. BRIDGE DECK CONCRETE OVERLAYS**

**531.01 Description.** This work shall consist of constructing a concrete overlay on an existing concrete bridge deck or approach slab.

**531.02 Materials.** Materials shall be according to the following.

Item.....	Article/Section
(a) Coarse Aggregate (Note 1) .....	1004.02
(b) Packaged, Dry, Rapid Hardening Mortar or Concrete .....	1018
(c) Portland Cement Concrete (Note 2) (Note 3) .....	1020
(d) Fibers for Concrete (Note 4).....	1014

Note 1. Coarse aggregate shall be crushed stone or crushed gravel.

Note 2. Concrete shall be Class BS with the following exceptions.

Overlay Type	Gradation
Fly Ash Ground Granulated Blast Furnace (GGBF) Slag High Reactivity Metakaolin (HRM) Microsilica	CA 11, CA 13, CA 14, or CA 16
Latex	CA 13, CA 14, or CA 16

Slump shall be 2-7 in. (50-175 mm). For latex overlays, the maximum slump may be increased if no visible segregation is observed.

For latex overlays, air content shall be a maximum of 7.0 percent and maximum water/cement ratio shall be 0.40.

For Class F fly ash overlays, fly ash shall replace cement at the maximum rate permitted according to Article 1020.05(c)(1)b. The replacement ratio shall be 1:1.

For Class C fly ash overlays, fly ash shall replace cement at a rate ranging from a minimum of 25 percent to the maximum rate permitted according to Article 1020.05(c)(1)c. The replacement ratio shall be 1:1.

For GGBF slag overlays, GGBF slag shall replace cement at a rate ranging from a minimum of 25 percent to the maximum rate permitted according to Article 1020.05(c)(2)b. The replacement ratio shall be 1:1.

For microsilica and HRM overlays, the cementitious factor (excluding microsilica or HRM) shall be 565 lb/cu yd (390 kg/cu m). The minimum amount of microsilica or HRM added to the mix shall be 33 lb/cu yd (20 kg/cu m) and the maximum shall be 37 lb/cu yd (22 kg/cu m).

For latex overlays, the cementitious factor shall be a minimum of 658 lbs/cu yd (335 kg/cu m), the dosage of the latex admixture shall be 24.5 gal/cu yd (121.3 L/cu m), the coarse aggregate shall be 42-50 percent by weight (mass) of total aggregate, no air entraining admixture shall be used, and water used shall be a maximum of 157 lb/cu yd (93.1 kg/cu m) (including free moisture on the fine and coarse aggregates).

Note 3. For HRM and microsilica overlays, the Contractor shall submit a specific batching sequence for verification by the Engineer. The submittal shall include whether a truck or stationary mixer will be used. For HRM overlays, the submittal shall include whether bulk or bagged HRM will be used. For microsilica overlays, the submittal shall include whether the microsilica to be used is a water based slurry, bulk densified, or bagged densified.

Note 4. Synthetic fibers, when required, shall be according to Article 1014.01, and 1014.04 or 1014.05, as applicable.

**531.03 Equipment.** Equipment shall be according to the following.

Item.....	Article/Section
(a) Concrete Equipment (Note 1) .....	1020.03
(b) Finishing Equipment .....	503.03
(c) Fogging Equipment .....	1103.17(k)
(d) Mechanical Scarifying Equipment (Note 2) .....	1101.16
(e) Hydro-Scarification Equipment (Note 3)	
(f) Hand-Held Blast Cleaning Equipment (Note 4)	
(g) Mechanical Blast Cleaning Equipment (Note 5)	
(h) Pull-Off Test Equipment (Note 6)	

Note 1. For latex concrete overlays, a mobile portland cement concrete plant shall be used according to Articles 1020.12 and 1103.04.

Note 2. Mechanical scarifying equipment shall be capable of uniformly scarifying or removing the old concrete surface and new patches to the depth required. The minimum width of the equipment shall be 3 ft (1 m).

Note 3. Hydro-scarification equipment shall consist of filtering and pumping units operating with a computerized, self-propelled robotic machine capable of removing sound concrete in a single pass to the specified depth and operating at a 16,000 psi (110 MPa) minimum water pressure with a 55 gal/min (208 L/min) minimum water flow rate.

Note 4. Hand-held blast cleaning shall be performed by high-pressure waterblasting or abrasive blasting. High-pressure waterblasting equipment shall have a minimum water pressure of 7000 psi (48 MPa) and have oil traps.

Note 5. Mechanical blast cleaning shall be performed by high-pressure waterblasting or shotblasting capable of removing weak concrete at the surface, including the microfractured concrete surface layer remaining as a result of mechanical scarification, and shall have oil traps.

Mechanical high-pressure waterblasting equipment shall be mounted on a wheeled carriage, include multiple nozzles mounted on a rotating assembly, and shall be operated with a 7000 psi (48 MPa) minimum water pressure. The distance between the nozzles and the deck surface shall be kept constant and the wheels shall maintain contact with the deck surface during operation.

Note 6. Equipment used to perform pull-off testing shall be on the Department's qualified product list "Pull-Off Test Equipment for Bridge Deck Overlays".

## CONSTRUCTION REQUIREMENTS

**531.04 General.** The Contractor shall control the runoff water generated by the various construction activities in such a manner as to minimize, to the maximum extent practicable, the discharge of untreated effluent into adjacent waters, and shall properly dispose of the solids generated according to Article 202.03. The Contractor shall submit a water management plan to the Engineer specifying the control measures to be used. The control measures shall be in place prior to the start of runoff water generating activities. Runoff water shall not be allowed to constitute a hazard to adjacent or underlying roadways, waterways, drainage areas or railroads nor be allowed to erode existing slopes.

**531.05 Preparation.** Sidewalks, curbs, drains, reinforcement, existing transverse and longitudinal joints, and other appurtenances which are to remain in place shall be protected from damage during scarification and cleaning operations.

- (a) Scarification. The scarification shall consist of removing the concrete using mechanical and hydro-scarifying equipment to the depth specified on the plans. The depth specified shall be measured from the existing concrete surface to the grout line between aggregates remaining after scarification. Power-driven hand tools shall be used for removal around areas to remain in place and areas not accessible to the scarifying equipment. Power-driven hand tools include jackhammers lighter than the nominal 45 lb (20 kg) class. Jackhammers or chipping hammers shall be operated at an angle less than 45 degrees measured from the surface of the slab.

Mechanical scarification equipment shall be used to remove the initial 1/4 in. (25 mm) minimum depth of concrete, creating a uniform roughened concrete surface. If the Contractor's use of mechanical scarifying equipment results in exposing, snagging, or

dislodging the top mat of reinforcing steel, the mechanical scarifying depth shall be reduced as necessary immediately. If the exposing, snagging, or dislodging the top mat of reinforcing steel cannot be avoided, the mechanical scarifying shall be stopped immediately and the remaining removal shall be accomplished using the hydro-scarification equipment. All damage to the existing reinforcement resulting from the Contractor's operation shall be repaired or replaced at no additional cost to the Department. Replacement shall include the removal of any additional concrete required to position or splice the new reinforcing steel. Undercutting of exposed reinforcement bars shall only be as required to replace or repair damaged reinforcement. Repairs to existing reinforcement shall be according to Section 530.

- (b) Sounding. Just prior to performing hydro-scarification, the deck shall be sounded, with unsound areas marked on the deck by the Engineer. A trial section, in an area of sound concrete, on the existing deck surface will be designated by the Engineer to calibrate the equipment settings to remove sound concrete to the required depth, in a single pass, and provide a highly roughened bondable surface. The trial section shall consist of approximately 30 sq ft (3 sq m). After calibration in an area of sound concrete, the equipment shall be moved to a second trial section, as designated by the Engineer, in an area containing unsound concrete to verify the calibrated settings are sufficient to remove the unsound concrete. If the calibrated settings are insufficient to remove the unsound concrete, the equipment may be moved back to an area of sound concrete and the calibration settings verified.

After the equipment settings are established, they shall be supplied to the Engineer and include the following.

- (1) Water pressure
- (2) Water flow rate
- (3) Nozzle type and size
- (4) Nozzle travel speed
- (5) Machine staging control (step/advance rate)

Hydro-scarification may begin after the calibration settings have been approved by the Engineer. At least the last 1/2 in. (13 mm) of removal shall be accomplished with hydro-scarification equipment.

The removal depth will be verified by the Engineer. If sound concrete is being removed below the desired depth, the equipment shall be recalibrated.

- (c) Cleaning. After hydro-scarification, the concrete shall be vacuum cleaned before the water and debris are allowed to dry and re-solidify to the deck. The vacuum shall be equipped with fugitive dust control devices capable of removing wet debris and water in the same pass. The vacuum shall also be capable of washing the deck with pressurized water prior to the vacuum operation to dislodge all debris and slurry from the deck surface. The use of alternative cleaning and debris removal methods to minimize driving heavy

vacuum equipment over the exposed reinforcement may be used subject to the approval of the Engineer.

**531.06 Patching.** After scarification and cleaning, the Engineer will sound the scarified concrete and survey the existing reinforcement condition. All remaining unsound concrete and unacceptably corroded reinforcement bars will be marked for additional removal and/or repairs and shall be completed according to Section 530 except as noted below.

In areas where unsound concrete extends below the specified removal depth and hydro-scarification completely removes unsound concrete, a full-depth repair shall be required when the bottom mat of reinforcement is exposed.

Full-depth patches shall be struck off to the scarified surface and then roughened with a suitable stiff bristled broom or wire brush to provide a rough texture. Hand finishing of the patch surface shall be kept to a minimum to prevent overworking of the surface.

Any removal required or made below the specified depth for scarification, which does not result in full-depth repair, shall be filled with the overlay material at the time of the overlay placement.

Undercutting of exposed reinforcement bars shall only be as required to replace or repair damaged or corroded reinforcement, or to perform a full depth repair.

**531.07 Final Surface Preparation.** Final surface preparation shall include the cleaning of all dust, debris, concrete fines, and other foreign substances from the surface including vertical faces of curbs, previously placed adjacent overlays, barrier walls up to a height of 1 in. (25 mm) above the overlay, depressions, and beneath reinforcement bars using hand-held blast cleaning methods.

If spoils from the scarification operation are allowed to dry and re-solidify on the surface, the surface shall be cleaned with mechanical blast cleaning equipment. Areas determined by the Engineer to be inaccessible to scarifying equipment shall be blast cleaned with hand-held equipment.

The Engineer may require surface pull-off testing of areas inaccessible to scarifying equipment. The Contractor shall provide the testing equipment in accordance with Illinois Test Procedure 304 "Pull-Off Test (Surface Method)". Prior to the start of testing, the Contractor shall submit to the Engineer a technical data sheet and material safety data sheet for the epoxy used to perform the testing. For solvents used to clean the equipment, a material safety data sheet shall be submitted. The Engineer will determine each test location, and each individual test shall have a minimum strength of 175 psi (1,207 kPa). In the case of a failing test, the Contractor shall adjust the blast cleaning method and re-clean the area. Testing will be repeated until satisfactory results are attained.

Exposed reinforcement bars shall be free of dirt, detrimental scale, paint, oil, and other foreign substances which may reduce bond with the concrete. Loose, scaling rust shall be removed by

rubbing with burlap, wire brushing, blast cleaning, or another method approved by the Engineer. Loose reinforcement bars, as determined by the Engineer, shall be retied.

Dust, concrete fines, debris, and water resulting from the surface preparation shall be confined and immediately removed. If concrete placement does not follow immediately after the final cleaning, the area shall be protected with anchored white polyethylene sheeting.

**531.08 Equipment Preparation.** Before placing the overlay, the finishing machine shall be operated over the full length of bridge segment to be overlaid to check support rails for deflection and confirm the minimum overlay thickness. If adjustments are needed, another check shall be performed.

**531.09 Placing.** Concrete placement shall be according to Article 503.07, 503.16, and the following.

The surface shall be cleaned to the satisfaction of the Engineer and shall be thoroughly wetted and maintained in a dampened condition with water for at least 12 hours before placement of the overlay. Excess water shall be removed by compressed air or by vacuuming prior to the beginning of overlay placement. Water shall not be applied to the surface within one hour before or at any time during placement of the overlay.

Internal vibration shall be performed along edges, adjacent to bulkheads, and where the overlay thickness exceeds 3 in. (75 mm). Internal vibration along the longitudinal edges of a pour shall be performed with a minimum of two hand-held vibrators, one on each edge of the pour. Hand finishing shall be performed along the edges of the pour from sidewalks, curbs, or work bridges.

A construction dam or bulkhead shall be installed in case of a delay of 30 minutes or more in the concrete placement operation.

Construction joints shall be formed. When required by the Engineer, the previously placed overlay shall be sawed full-depth to a straight and vertical edge before fresh concrete is placed. The Engineer will determine the extent of the removal. When longitudinal joints are not shown on the plans, the locations shall be subject to approval by the Engineer and shall not be located in the wheel paths.

The Contractor shall stencil the date of construction (month and year) and the appropriate letters into the overlay before it takes its final set, as follows.

- (a) MS, for MicroSilica
- (b) MSFA, when fly ash is used in the silica fume mix design, for MicroSilica Fly Ash
- (c) MSF, for MicroSilica with Fibers
- (d) MSFAF, when fly ash is used in the silica fume mix design, for MicroSilica Fly Ash with Fibers
- (e) LX, for LateX
- (f) LXF, for LateX with Fibers

- (g) HRM, for High-Reactivity Metakaolin
- (h) HRMFA, when fly ash is used in the HRM mix design, for High-Reactivity Metakaolin Fly Ash
- (i) HRMF, for High-Reactivity Metakaolin with Fibers
- (j) HRMFAF, when fly ash is used in the HRM mix design, for High-Reactivity Metakaolin Fly Ash with Fibers
- (k) FA, for Fly Ash
- (l) FAF, for Fly Ash with Fibers
- (m) GGBF, for Ground Granulated Blast Furnace slag
- (n) GGBFF, for Ground Granulated Blast Furnace slag with Fibers

The stencil shall be in a noticeable location, as determined by the Engineer, for each stage of construction outside of the grooving where possible and within 3 ft (1 m) of an abutment joint. The characters shall be 3 to 4 in. (75 to 100 mm) in height, 1/4 in. (5 mm) in depth and face the centerline of the roadway.

**531.10 Weather and Other Limitations.** Temperature control for concrete placement shall be according to Article 1020.14(b). The concrete protection from low air temperatures during the curing period shall be according to Article 1020.13(d). Concrete shall not be placed when rain is expected during the working period. If night placement is required, illumination and placement procedures will be subject to approval by the Engineer.

Concrete delivery vehicles driven on the structure shall be limited to a maximum load of 6 cu yd (4.6 cu m).

Truck mixers, concrete pumps, or other heavy equipment will not be permitted on any portion where the top reinforcing mat has been exposed. Conveyors, buggy ramps, and pump piping shall be installed in a way that will not displace undercut reinforcement bars. Air compressors may be operated on the deck only if located directly over a pier and supported off undercut reinforcement bars. Compressors will not be allowed to travel over undercut reinforcement bars.

Concrete removal may proceed during final cleaning and concrete placement on adjacent portions, provided the removal does not interfere with the cleaning or placement operations.

Water or contaminants from the hydro-scarification shall not be permitted in areas where the new overlay has been placed until the overlay has cured a minimum of 24 hours.

No concrete shall be removed within 6 ft (1.8 m) of a newly-placed overlay until the concrete has obtained a minimum compressive strength of 3000 psi (20,700 kPa) or flexural strength of 600 psi (4,150 kPa).

**531.11 Curing.** For silica fume, HRM, GGBF, and fly ash concrete overlays, the surface shall be continuously wet cured for at least seven days according to Articles 1020.13(a)(5) or (a)(6).

For latex modified concrete overlays, the surface shall be continuously wet cured for at least 48 hours according to Articles 1020.13(a)(3), (a)(5), or (a)(6). After the wet cure is completed, all layers of covering materials shall be removed to allow for a dry cure for at least 48 hours. If the ambient temperature falls below 45°F (10°C) during either the wet or dry curing periods, the time below 45°F (10°C) will not be included in the 96 hour curing period. If there is sufficient rain to wet the surface of the overlay for more than one hour of the dry cure period, the wet time will not be included in the 48 hour dry cure period.

When the mats or blankets have been pre-dampened, excess water shall not be allowed to drip onto the overlay during placement.

**531.12 Testing.** The Engineer reserves the right to conduct pull-off tests on the overlay to determine if any areas are not bonded to the underlying concrete. The overlay will be tested according to the Illinois Test Procedure 305 "Pull-Off Test (Overlay Method)", and the Contractor shall provide the test equipment. Prior to the start of testing, the Contractor shall submit to the Engineer a technical data sheet and material safety data sheet for the epoxy used to perform the testing. For solvents used to clean the equipment, a material safety data sheet shall be submitted. Each individual test shall have a minimum strength of 150 psi (1,034 kPa). If the test results are unacceptable, the overlay shall be removed and replaced at the locations determined by the Engineer. When removing portions of an overlay, the saw cut shall be a minimum depth of 1 in. (25 mm).

If the overlay is to remain in place, all core holes due to testing shall be filled with a rapid set mortar or concrete. Only enough water to permit placement and consolidation by rodding shall be used, and the material shall be struck-off flush with the adjacent material.

For a rapid set mortar mixture, one part packaged rapid set cement shall be combined with two parts fine aggregate, by volume; or a packaged rapid set mortar shall be used. For a rapid set concrete mixture, a packaged rapid set mortar shall be combined with coarse aggregate according to the manufacturer's instructions; or a packaged rapid set concrete shall be used. Mixing of a rapid set mortar or concrete shall be according to the manufacturer's instructions.

**531.13 Opening to Traffic.** No traffic or construction equipment will be permitted on the overlay until after the cure period and the concrete has obtained a minimum compressive strength of 4000 psi (27,500 kPa) or flexural strength of 675 psi (4,650 kPa).

**531.14 Method of Measurement.** Scarification will be measured for payment in square yards (square meters). No additional payment will be made for multiple passes of the equipment.

The concrete overlay will be measured for payment in square yards (square meters).

Additional concrete placed with the overlay, required to fill all depressions below the specified thickness will be measured for payment in cubic yards (cubic meters). The volume will be determined by subtracting the theoretical volume of the overlay from the ticketed volume of overlay delivered minus the volume estimated by the Engineer left in the last truck at the end of the overlay placement. The theoretical cubic yard (cubic meter) quantity for the overlay will be

determined by multiplying the plan surface area of the overlay times the specified thickness of the overlay.

Partial depth removal in concurrence with hydro-scarification will not be measured for payment.

**531.15 Basis of Payment.** Scarification will be paid for at the contract unit price per square yard (square meter) for BRIDGE DECK SCARIFICATION, of the depth specified.

Silica fume concrete overlay will be paid for at the contract unit price per square yard (square meter) for BRIDGE DECK MICROSILICA CONCRETE OVERLAY, of the thickness specified. Latex modified concrete overlay will be paid for at the contract unit price per square yard (square meter) for BRIDGE DECK LATEX CONCRETE OVERLAY, of the thickness specified. HRM concrete overlay will be paid for at the contract unit price per square yard (square meter) for BRIDGE DECK HRM CONCRETE OVERLAY, of the thickness specified. GGBF or fly ash concrete overlay will be paid for at the contract unit price per square yard (square meter) for BRIDGE DECK GGBF OR FLY ASH CONCRETE OVERLAY, of the thickness specified.

The additional volume of overlay required to fill all depressions below the specified thickness and/or for grade adjustments will be paid for at the Contractor's actual material cost for the concrete per cubic yard (cubic meter) times an adjustment factor. For volumes 15 percent or less over the theoretical volume of the overlay, the adjustment factor will be 1.15. For volumes greater than 15 percent, the adjustment factor will be 1.25 for that volume over 15 percent of the theoretical volume of the overlay.

Concrete protected according to Article 1020.13(d) will be paid according to Article 503.22.

Areas requiring additional partial depth or full depth removal of unsound concrete after hydro-scarification, as determined by the Engineer, will be paid according to Article 109.04.

Reinforcement bars repaired in-kind, as approved by the Engineer, will be paid according to Article 109.04.

When the Engineer conducts pull-off tests on the existing surface or overlay and they are acceptable, Contractor expenses incurred due to testing and filling core holes will be paid according to Article 109.04. Unacceptable pull-off tests will be at no additional cost to the Department."

**DECK SLAB REPAIR**

Effective: January 1, 2026

Add the following Section 530 to the Standard Specifications:

**“SECTION 530. DECK SLAB REPAIR**

**530.01 Description.** This work shall consist of the removal of existing hot-mix asphalt (HMA) surface and loose and deteriorated concrete from a bridge deck, and the replacement with new concrete to the existing top of deck.

Work will be classified as follows.

Removal Type	Description
HMA Surface Removal	Removal of the HMA surface from the concrete bridge deck.
Deck Slab Repair (Partial)	Removal and replacement of the concrete deck, at least 3/4 in. (20 mm) but not more than 1/2 of the concrete deck thickness.
Deck Slab Repair (Full Depth, Type I)	Removal and replacement of the concrete deck to full depth, for an area 1 ft x 1 ft (300 mm x 300 mm) to 5 sq ft (0.5 sq m).
Deck Slab Repair (Full Depth, Type II)	Removal and replacement of the concrete deck to full depth, for an area greater than 5 sq ft (0.5 sq m).

**530.02 Materials.** Materials shall be according to the following.

Item.....	Article/Section
(a) Portland Cement Concrete (Note 1) .....	1020
(b) Reinforcement Bars .....	508

Note 1. Class PP-1, PP-2, PP-3, PP-4, PP-5, or BS concrete shall be used unless otherwise noted on the plans.

**530.03 Equipment.** Equipment shall be according to the following.

Item.....	Article/Section
(a) Concrete Equipment .....	1020.03
(b) Finishing Equipment .....	503.03
(c) Hydrodemolition Equipment .....	1101.11
(e) Hydro-Scarification Equipment (Note 1)	

Note 1. Hydro-scarification equipment shall consist of filtering and pumping units operating with a computerized, self-propelled robotic machine capable of removing

unsound concrete in a single pass to the specified depth and operating at a 16,000 psi (110 MPa) minimum water pressure with a 55 gal/min (208 L/min) minimum water flow rate.

## CONSTRUCTION REQUIREMENTS

**530.04 General.** Sidewalks, curbs, drains, reinforcement, existing transverse and longitudinal joints, and other appurtenances which are to remain in place shall be protected from damage during removal and cleaning operations.

The Contractor shall control the runoff water generated by the various construction activities in such a manner as to minimize, to the maximum extent practicable, the discharge of untreated effluent into adjacent waters, and shall properly dispose of the solids generated according to Article 202.03. The Contractor shall submit a water management plan to the Engineer specifying the control measures to be used. The control measures shall be in place prior to the start of runoff water generating activities. Runoff water shall not be allowed to constitute a hazard to adjacent or underlying roadways, waterways, drainage areas or railroads nor be allowed to erode existing slopes.

**530.05 HMA Surface Removal.** The existing HMA surface and waterproofing membrane shall be removed and disposed of according to Articles 440.04 and 440.06, except milling equipment will not be allowed if the deck is to receive a waterproofing membrane system. Removal of the HMA surface by the use of radiant or direct heat will not be permitted. If the HMA surface or waterproofing membrane contains asbestos fibers, removal shall be according to the Recurring Special Provision "Asbestos Waterproofing Membrane or Asbestos Hot-Mix Asphalt Surface Removal".

**530.06 Concrete Removal.** Concrete shall be removed, as determined by the Engineer, in areas of loose, disintegrated, and unsound concrete. Areas designated for partial depth repair in which unsound concrete is found to extend below half the concrete deck thickness shall be removed to full depth.

A concrete saw shall be used to provide vertical edges 3/4 in. (20 mm) deep around the perimeter of the area to be patched. Where reinforcement bars lack sufficient concrete cover, the depth shall be reduced as directed by the Engineer. A saw cut will not be required if the deck is to get an overlay, or along the face of the curb, parapet or joint, or when sharp vertical edges are provided by hydrodemolition.

- (a) **Partial-Depth.** The loose and unsound concrete shall be removed using power-driven hand tools or hydrodemolition equipment. Power-driven hand tools include jackhammers less than or equal to the nominal 45 lb (20 kg) class. Chipping hammers heavier than the nominal 15 lb (7 kg) class shall not be used for removing concrete from below reinforcing bars, or for removal within 1 ft (300 mm) of existing beams, girders, or other structural members that are to remain in service. Jackhammers and chipping hammers shall not be operated at an angle less than 45 degrees measured from the surface of the deck.

- (b) Full Depth. Full depth removal shall be performed according to Article 501.05 except that hydraulic impact equipment may be permitted in areas of full depth removal more than 1 ft (300 mm) away from the edges of existing beams, girders or other supporting structural members or more than 1 ft (300 mm) from the boundaries of full depth repairs.

Forms for full depth repair may be supported by hangers with adjustable bolts or by blocking from the beams below. When approved by the Engineer, forms for Type I patches may be supported by No. 9 (3.8 mm) wires or other devices attached to the reinforcement bars.

Exposed reinforcement bars and newly exposed concrete shall be blast cleaned. If the Engineer determines the bond between existing concrete and reinforcement bars within the patch area has been destroyed, the concrete adjacent to the bar shall be removed to a depth that will permit new concrete to bond to the entire periphery of the exposed bar. A minimum of 1 in. (25 mm) clearance will be required. If the Engineer enlarges a designated removal area due to deterioration beyond the limits previously designated, a new saw cut shall be made around the extended area before additional removal is begun. The removal area shall not be enlarged solely to correct debonded reinforcement or deficient lap lengths.

**530.07 Reinforcement Treatment.** Care shall be exercised during concrete removal to protect the reinforcement bars and structural steel from damage. Damage to the reinforcement bars or structural steel to remain in place shall be repaired or replaced. Existing reinforcement bars shall remain in place and loose bars shall be tied. Reinforcing bars which have been removed with the patch or lost at least 25 percent of their original cross-sectional area due to corrosion shall be supplemented by new in-kind reinforcement bars. New bars shall be lapped a minimum of 32 bar diameters to existing bars. A mechanical splicer capable of developing in tension at least 125 percent of the yield strength of the existing bar shall be used when it is not feasible to provide the minimum bar lap. No welding of bars will be permitted.

**530.08 Cleaning.** After concrete removal and reinforcement repairs, the repair areas shall be cleaned of dust and debris. Once the initial cleaning is completed, the repair areas shall be blast cleaned to a roughened appearance free from concrete fines and foreign matter.

Exposed reinforcement bars shall be free of dirt, detrimental scale, paint, oil, or other foreign substances which may reduce bond with the concrete. Loose, scaling rust shall be removed by rubbing with burlap, wire brushing, blast cleaning, or another method approved by the Engineer.

Dust, concrete fines, debris, and water resulting from the blast cleaning shall be confined and immediately removed. If concrete placement does not follow immediately after the final cleaning, the area shall be protected with anchored polyethylene sheeting.

**530.09 Placing.** Concrete placement shall be according to Articles 503.07, 503.16, 1020.14(b), and the following.

The patch area shall be cleaned to the satisfaction of the Engineer and shall be thoroughly wetted and maintained in a dampened condition with water for at least 12 hours before placement of the concrete. Excess water shall be removed by compressed air or by vacuuming prior to the beginning of concrete placement. Water shall not be applied to the surface within one hour before or at any time during placement of the concrete.

When an overlay system is not specified, the patches shall be finished according to Article 503.16(a), followed by a light brooming.

**530.10 Curing and Protection.** Concrete patches shall be cured according to Articles 1020.13(a)(3) or (a)(5). The curing period shall be three days for Class PP-1, PP-2, PP-3, PP-4, and PP-5 concrete, and seven days for Class BS concrete. When the air temperature is below 55° F (13° C), the Contractor shall cover the patch according to Article 1020.13(d)(1) with minimum R12 insulation.

A 72 hour minimum drying period shall be required before placing waterproofing or HMA surfacing.

**530.11 Opening to Traffic.** No traffic will be permitted on a patch until after the cure period and the concrete has obtained a minimum compressive strength of 4000 psi (27.6 MPa) or flexural strength of 675 psi (4.65 MPa). Construction equipment will be permitted on a patch during the cure period if the concrete has obtained the minimum required strength when the specimens are cured with the patch.

**530.12 Method of Measurement.** HMA surface removal and deck slab repair will be measured for payment in place and the area computed in square yards (square meters).

**530.13 Basis of Payment.** HMA surface removal will be paid for at the contract unit price per square yard (square meter) for HOT-MIX ASPHALT SURFACE REMOVAL (DECK).

Areas removed and replaced up to and including a depth of half the concrete deck thickness will be paid for at the contract unit price per square yard (square meter) for DECK SLAB REPAIR (PARTIAL). Areas removed and replaced to a depth greater than half the concrete deck thickness will be paid for at the contract unit price per square yard (square meter) for DECK SLAB REPAIR (FULL DEPTH, of the type specified).

Concrete protected according to Article 1020.13(d) will be paid according to Article 503.22.

Reinforcement bars repaired in-kind, as approved by the Engineer, will be paid according to Article 109.04."

## LONGITUDINAL TINING (BDE)

Effective: January 1, 2026

Revise the first three paragraphs of Article 420.09(e)(1) of the Standard Specifications to read:

- “(1) Type A. Type A final finish shall be obtained by the use of a carpet drag composed of an artificial turf followed immediately by a mechanically operated metal comb longitudinal tining device.

The artificial turf shall be made of molded polyethylene with synthetic turf blades approximately 0.85 in. (20 mm) long and contain approximately 7,200 individual blades per 1 sq ft (0.1 sq m). The artificial turf shall be attached to a device that will permit control of the time and rate of texturing. The artificial turf carpet shall be full pavement width and of sufficient size that during the finishing operation, approximately 2 ft (600 mm) of carpet in the direction of drag (i.e., parallel to the pavement centerline) will be in contact with the pavement surface over the entire pavement width. The drag shall be operated in a longitudinal direction to produce a uniform appearing finish. If necessary for maintaining contact with the pavement surface, the carpet may be weighted.

The metal comb shall consist of a single line of tempered spring steel tines uniformly spaced at 3/4 in. (19 mm). The tines shall be flat and of a size and stiffness sufficient to produce a groove of the specified dimensions in the plastic concrete without tearing of the pavement surface. The mechanically operated metal comb shall be either an exclusive piece of equipment which is mechanically self-propelled or shall be combined with the curing equipment. The artificial turf carpet drag may be attached to this piece of equipment provided a surface texture is produced satisfactory to the Engineer. The tining device shall be operated to produce a pattern of grooves, 1/8 to 3/16 in. (3 to 5 mm) deep and 1/10 to 1/8 in. (2.5 to 3 mm) wide along the pavement in a single pass. The tining shall be operated parallel to the longitudinal joint or edge of pavement and shall not deviate more than 1 in. (25 mm) in 25 ft (8 m). Tining shall be withheld 1 to 1 1/2 in. (25 to 38 mm) from a longitudinal joint or pavement edge.

Hand tining or tining with a mechanically operated comb combined with the curing equipment specified in Article 1101.09 will be permitted where the specifications permit hand finishing or screeds, one lane construction up to 16 ft (5 m) wide, gaps, projects with a net length of 1/2 mile (800 m) or less, and where the production rate on any paving day will be less than 1,500 cu yd (1200 cu m) per day. A foot bridge shall be provided for the hand tining operation for all pavement over 12 ft (3.6 m) wide, unless it can be demonstrated that an alternate texturing operation produces satisfactory results.”

## **MODIFIED LONGITUDINAL CONSTRUCTION JOINT (BDE)**

Effective: January 1, 2026

Add the following to Article 420.05 to the Standard Specifications:

- “(f) Modified Longitudinal Construction Joint. Modified longitudinal construction joints shall be according to Article 420.05(b), except a 3/4 in. (19 mm) dowel bar shall be used in place of the tie bar and the minimum pull-out strength criteria and testing is not applicable. In addition, the face of the slab shall be coated with a bond breaking application of curing compound, and a light coating of oil shall be uniformly applied to the dowel bar.”

80478

## **SINUSOIDAL RUMBLE STRIPS (BDE)**

Effective: January 1, 2026

Revise Section 642 of the Standard Specifications to read:

### **“SECTION 642. RUMBLE STRIPS**

**642.01 Description.** This work shall consist of constructing rumble strips into new or existing pavement.

**642.02 Equipment.** The equipment shall be a self-propelled milling machine with a rotary-type cutting head(s). The cutting head(s) shall be suspended from the machine such that it can align itself with the slope of the pavement and any irregularities in the pavement surface. The teeth of the cutting head(s) shall be arranged to provide a smooth cut, with no more than a 1/8 in. (3 mm) difference between peaks and valleys.

Prior to commencement of the work, the Contractor shall demonstrate the ability of the equipment to achieve the desired results without damaging the pavement.

### **CONSTRUCTION REQUIREMENTS**

**642.03 General.** The rumble strips shall be cut to the dimensions shown on the plans.

Rumble strips shall be omitted within the limits of structures, entrances, side roads, entrance ramps, and exit ramps. In portland cement concrete, rumble strips shall not be placed within 6 in. (150 mm) of transverse joints.

Cuttings resulting from this operation shall be disposed of according to Article 202.03 and the pavement swept clean.

**642.04 Method of Measurement.** This work will be measured for payment in place in feet (meters) along the edge of pavement for shoulder applications and along the centerline of pavement for centerline applications. Measurement will include both the cut and uncut sections of the rumble strips with exceptions for bridge decks, approach slabs, turn lanes, entrances, and other sections where rumble strips have been omitted.

**642.05 Basis of Payment.** This work will be paid for at the contract unit price per foot (meter) for SHOULDER RUMBLE STRIPS, 8 INCH; SHOULDER RUMBLE STRIPS, 16 INCH; or SINUSOIDAL RUMBLE STRIPS, 14 INCH.”

## STRUCTURAL REPAIR OF CONCRETE (BDE)

Effective: January 1, 2026

Add the following Section 532 to the Standard Specifications:

### “SECTION 532. STRUCTURAL REPAIR OF CONCRETE

**532.01 Description.** This work shall consist of repairing concrete on a bridge substructure, culvert, retaining wall, or other structure.

**532.02 Materials.** Materials shall be according to the following.

Item	Article/Section
(a) Portland Cement Concrete (Note 1) .....	1020
(b) R1, R2, or R3 Concrete .....	1018
(c) Packaged, Dry, Combined Materials for Concrete .....	1017.02, 1017.03
(d) High Performance Shotcrete .....	1015
(e) Reinforcement Bars.....	1006.10
(f) Anchor Bolts .....	1006.09
(g) Water.....	1002
(h) Curing Compound .....	1022.01
(i) Cotton Mats.....	1022.02
(j) Protective Coat.....	1023
(k) Epoxy (Note 2) .....	1025
(l) Mechanical Bar Splicers .....	508.06(c)
(m) Polymer Modified Portland Cement Mortar (Note 3)	

Note 1. The concrete shall be Class SI, except the cement and finely divided minerals shall be a minimum 6.65 cwt/cu yd (395 kg/cu m) with no reductions permitted, the cement shall not be below 4.70 cwt/cu yd (279 kg/cu m), the coarse aggregate shall be a CA 16, the strength shall be a minimum 4000 psi (27,500 kPa) at 28 days, and the slump shall be 5-10 in. (125-250 mm). A self-consolidating concrete mixture will also be permitted. Slump flow range, visual stability index, J-Ring, L-Box, and hardened visual stability index requirements shall be according to Article 1020.04.

Note 2. ASTM C 881, Type IV, Grade 2 or 3, Class A, B, or C may also be used.

Note 3. Polymer modified portland cement mortar shall be a packaged product consisting of cementitious materials, fine aggregate, and a polymer modifier; and shall have successfully completed and remain current with the AASHTO Product Eval and Audit Rapid Hardening Concrete Patching Materials (RHCP) testing program. The mortar shall be a workable mix capable of bonding and holding its own plastic weight when mixed and placed according to manufacturer's instructions on vertical and overhead surfaces. It shall have a minimum compressive strength of 1,500 psi (10,300 kPa) at 24 hours, 4,000 psi (27,500 kPa) at 7 days, and 5,000 psi (34,500 kPa) at 28 days when tested according to

ASTM C 109 or AASHTO T 106. In addition, the mortar shall have a minimum bond strength of 1,500 psi (10,300 kPa) at 7 days when tested according to ASTM C 882. For prestressed concrete applications, the mortar shall have a water-soluble chloride ion content of less than 0.06 percent by weight of cementitious material when tested according to ASTM C 1218 or AASHTO T 260; and for non-prestressed concrete applications, the water-soluble chloride ion content shall be less than 0.15 percent by weight of cementitious material. The Department will maintain a Qualified Product List of Polymer Modified Portland Cement Mortar.

**532.03 Equipment.** Equipment shall be according to Article 503.03 and the following.

Item	Article/Section
(a) Hydrodemolition Equipment.....	1101.11
(b) High Performance Shotcrete Equipment (Note1)	

Note 1. The batching, mixing, pumping, hose, nozzle, and auxiliary equipment shall be for the wet-mix shotcrete method and meet the requirements of ACI 506R.

### **CONSTRUCTION REQUIREMENTS**

**532.04 General.** The repair method shall be either formed concrete repair or shotcrete according to the following.

- (a) Formed Concrete Repair. For formed concrete repair, a subsequent patch to repair the placement point after initial concrete placement will not be allowed. As an example, this may occur in a vertical location located at the top of the repair.

Formed concrete repair shall not be used for overhead applications except as noted for polymer modified portland cement mortar.

Polymer modified portland cement mortar shall only be used for repairs between 3/8 in. (10 mm) and 2 in. (50 mm) deep on horizontal, vertical, and overhead surfaces.

- (b) Shotcrete. Shotcrete shall not be used for any repair greater than 6 in. (150 mm) in depth, except in horizontal applications where the shotcrete may be placed from above in one lift.

Shotcrete shall not be used for column repairs greater than 4 in. (100 mm) in depth, unless the shotcrete mixture contains 3/8 in. (9.5 mm) aggregate.

The Contractor shall provide a current copy of ACI 506R to the Engineer a minimum of one week prior to the start of construction.

The shotcrete personnel who perform the work shall have current American Concrete Institute (ACI) nozzlemen certification for vertical wet and overhead wet applications,

except one individual may be in training. This individual shall be adequately supervised by a certified ACI nozzlemen as determined by the Engineer and a copy of the nozzlemen certificate(s) provided to the Engineer.

**532.05 Temporary Shoring or Cribbing.** When a temporary shoring or cribbing support system is required, the Contractor shall provide details and computations, prepared and sealed by an Illinois Licensed Structural Engineer, to the Department for approval. Whenever possible, the support system shall be installed prior to starting the associated concrete removal. If no system is specified, but during the course of removal the need for temporary shoring or cribbing becomes apparent or is directed by the Engineer due to a structural concern, the Contractor shall not proceed with any further removal work until an approved support system is installed.

**532.06 Concrete Removal.** The Contractor shall provide ladders or other appropriate equipment for the Engineer to mark the removal areas. Repair configurations will be kept simple, and squared corners will be indicated whenever possible. The repair perimeter shall be sawed a depth of 1/2 in. (13 mm) or less, as required to avoid cutting the reinforcement. If the concrete is broken or removed beyond the limits of the initial saw cut, the new repair perimeter shall be recut. The areas to be repaired shall have all loose, unsound concrete removed completely by the use of hydrodemolition equipment or chipping hammer with a 15 lb. (7 kg) maximum class. The concrete removal shall extend along the reinforcement bar until the reinforcement is free of bond inhibiting corrosion. Reinforcement bars with 50 percent or more exposed area shall be undercut to a depth of 3/4 in. (19 mm) or the diameter of the reinforcement bar, whichever is greater.

The minimum repair depth shall be 1 in. (25 mm). The substrate profile shall be  $\pm 1/16$  in. ( $\pm 1.5$  mm). The perimeter of the repair area shall have a vertical face.

If sound concrete is encountered before existing reinforcement bars are exposed, further removal of concrete shall not be performed unless the minimum repair depth is not met.

If a repair is located at the ground line, any excavation required below the ground line to complete the repair shall be included in this work.

Once concrete removal has started, the Contractor shall have 14 calendar days to complete each repair location.

The Engineer shall be notified of concrete removal that exceeds 6 in. (150 mm) in depth, one fourth the cross section of a structural member, more than half the vertical column reinforcement is exposed in a cross section, more than six consecutive reinforcement bars are exposed in any direction, within 1.5 in. (38 mm) of a bearing area, or other structural concern. Excessive deterioration or removal may require further evaluation of the structure or installation of temporary shoring and cribbing support system.

**532.07 Surface Preparation.** Prior to placing the concrete or shotcrete, the Contractor shall blast clean the repair area and exposed reinforcement to provide a surface that is free of oil, dirt, and loose material.

The repair area and perimeter vertical face shall have a rough surface. Just prior to concrete or shotcrete placement, the repair area shall be saturated with water to a saturated surface-dry condition. Any standing water shall be removed.

If a succeeding layer of shotcrete is to be applied, the initial shotcrete surface and remaining exposed reinforcement shall be free of curing compound, oil, dirt, loose material, rebound, and overspray. Preparation may be by lightly brushing or blast cleaning if the previous shotcrete surface was less than 36 hours prior. If more than 36 hours prior, the surface shall be prepared by blast cleaning.

**532.08 Reinforcement.** Exposed reinforcement bars shall be cleaned of concrete and corrosion by blast cleaning. After cleaning, exposed reinforcement will be evaluated to determine if replacement or additional reinforcement bars are required.

Reinforcing bars that have been cut or have lost 25 percent or more of their original cross-sectional area shall be supplemented by new in kind reinforcement bars. New bars shall be lapped a minimum of 32 bar diameters to existing bars. A mechanical bar splicer shall be used when it is not feasible to provide the minimum bar lap. No welding of bars will be permitted.

Intersecting reinforcement bars shall be tightly secured to each other using 0.006 in. (0.15 mm) or heavier gauge tie wire and shall be adequately supported to minimize movement during concrete placement or application of shotcrete.

Where the depth of concrete removal is greater than 8 in. (205 mm) and there is no existing reinforcement extending into the repair area, the Contractor shall anchor the new concrete to the existing concrete with 3/4 in. (19 mm) diameter hook bolts spaced at 15 in. (380 mm) maximum centers both vertically and horizontally, and a minimum of 12 in. (305 mm) away from the perimeter of the repair according to Section 584.

**532.09 Repair Methods.** Within 3 calendar days of the surface preparation and after the repair areas are approved by the Engineer, the concrete or shotcrete shall be placed according to the following.

- (a) Formed Concrete Repair. Falsework and forms shall be according to Articles 503.05 and Article 503.06. Formwork shall provide a smooth and uniform concrete finish and shall approximately match the existing concrete structure. Air vents may be provided to reduce voids and improve surface appearance. The Contractor may use exterior mechanical vibration, as approved by the Engineer, to release air pockets. The concrete shall be Class SI concrete; packaged R1, R2, or R3 concrete; packaged, dry, combined materials for concrete; or polymer modified portland cement mortar. The concrete shall be placed and consolidated according to Article 503.07.

Curing shall be according to Article 1020.13.

The surfaces of the completed repair shall be finished according to Article 503.15.

- (b) Shotcrete. In the field, shotcrete shall be tested for air content according to Illinois Modified AASHTO T 152 or AASHTO T 152. The sample shall be obtained from the discharge end of the nozzle by shooting a pile large enough to scoop a representative amount for filling the air meter measuring bowl. Shotcrete shall not be shot directly into the measuring bowl for testing.

Compressive strength shall be according to ASTM C 1140, except the test panel shall be cured according to Article 1020.13(a)(3) or (5) while stored at the jobsite and during delivery to the laboratory. At the discretion of the Engineer, the test panel may be reduced to 18x18x3.5 in. (457x457x89 mm).

The method of alignment control (i.e., ground wires, guide strips, depth gages, depth probes, and formwork) to ensure the specified shotcrete thickness and reinforcing bar cover is obtained shall be according to ACI 506R. Ground wires shall be removed after completion of cutting operations. Guide strips and formwork shall be of dimensions and a configuration that do not prevent proper application of shotcrete. Metal depth gauges shall be cut 1/4 in. (6 mm) below the finished surface. All repaired members shall be restored as close as practicable to their original dimensions.

Air temperature limits according to the first paragraph of Article 1020.14(b) shall apply in cold weather. Shotcrete shall not be applied when the air temperature is greater than 90 °F (32 °C). The applied shotcrete shall have a minimum temperature of 50 °F (10 °C) and a maximum temperature of 90 °F (32 °C). The shotcrete shall not be applied during periods of rain unless protective covers or enclosures are installed. If necessary, lighting shall be provided to provide a clear view of the shooting area.

The shotcrete shall be applied according to ACI 506R and shall be done in a manner that does not result in cold joints, laminations, sandy areas, voids, sags, or separations. In addition, the shotcrete shall be applied in a manner that results in maximum densification of the shotcrete. Shotcrete which is identified as being unacceptable while still plastic shall be removed and re-applied.

The nozzle shall normally be at a distance of 2-5 ft. (0.6-1 m) from the receiving surface and shall be oriented at right angles to the receiving surface. Exceptions to this requirement will be permitted to fill corners, encase large diameter reinforcing bars, or as approved by the Engineer. For any exception, the nozzle shall never be oriented more than 4 degrees from the surface. Care shall be taken to keep the front face of the reinforcement bar clean during shooting operations. Shotcrete shall be built up from behind the reinforcement bar. Accumulations of rebound and overspray shall be continuously removed prior to application of new shotcrete. Rebound material shall not be incorporated in the work.

Whenever possible, shotcrete shall be applied to the full thickness in a single layer. When two or more layers are required, the minimum number shall be used and shall be done in a manner without sagging or separation. A flash coat (i.e. a thin layer of up to 1/4 in. (6 mm) applied shotcrete) may be used as the final lift for overhead applications.

Prior to application of a succeeding layer of shotcrete, the initial layer of shotcrete shall be prepared according to the surface preparation and reinforcement bar cleaning requirements. Upon completion of the surface preparation and reinforcement bar treatment, water shall be applied according to the surface preparation requirements unless the surface is moist. The second layer of shotcrete shall then be applied within 30 minutes.

Shotcrete shall be cut back to line and grade using trowels, cutting rods, screeds or other suitable devices. The shotcrete shall be allowed to stiffen sufficiently before cutting. For depressions, cut material may be used for small areas. Rebound material shall not be incorporated in the work. For the final finish, a wood float or a manufacturer approved finishing aid shall be used to approximately match the existing concrete texture.

Contractor operations for curing shall be continuous with shotcrete placement and finishing operations. Curing shall be accomplished using wetted cotton mats, membrane curing, or a combination of both. Cotton mats shall be applied according to Article 1020.13(a)(5), except the exposed layer of shotcrete shall be covered within 10 minutes after finishing and wet curing shall begin immediately. Curing compound shall be applied according to Article 1020.13(a)(4), except the curing compound shall be applied as soon as the shotcrete has hardened sufficiently to prevent marring the surface, and each of the two separate applications shall be applied in opposite directions to ensure coverage. Note 5 of the Index Table in Article 1020.13 shall also apply.

When a shotcrete layer is to be covered by a succeeding shotcrete layer within 36 hours, the repair area shall be protected by wet curing with either burlap or cotton mats until the succeeding layer is applied. Intermittent hand fogging may be used for the first hour and a half if wet curing with mats begins within 10 minutes after fogging has ceased.

The curing period shall be for 7 days, except when there is a succeeding layer of shotcrete. In this instance, the initial shotcrete layer shall be cured until the surface preparation and reinforcement bar treatment is started.

The concrete or shotcrete shall not be placed when frost is present on the surface of the repair area, or the surface temperature of the repair area is less than 40 °F (4 °C). All repaired members shall be restored as close as practicable to their original dimensions.

If temperatures below 45 °F (7 °C) are forecast during the curing period, Protection Method I according to Article 1020.13(d)(1) or Protection Method II according to Article 1020.13(d)(2) shall be used.

**532.10 Protective Coat.** Protective coat shall be applied to the completed repair at reinforcement bar locations with less than 3/4 in. (19 mm) of cover according to Article 503.19, except blast cleaning shall be performed to remove curing compound.

**532.11 Inspection.** After curing but no sooner than 28 days after placement of concrete or shotcrete, the Contractor shall provide ladders or other necessary equipment for the Engineer to inspect the repaired areas.

A repaired area with cracks, voids, or delamination shall be considered as nonconforming. Any of the following shall be cause for removal and replacement of a repaired area.

- (a) A single surface crack greater than 0.01 in. (0.25 mm) in width and greater than 12 in. (300 mm) in length.
- (b) Two or more surface cracks greater than 0.01 in. (0.25 mm) in width that total greater than 24 in. (600 mm) in length.
- (c) Map cracking in one or more regions totaling 15 percent or more of the gross surface area of the repair.
- (d) Two or more surface voids with least dimension of 3/4 in. (19 mm) each.
- (e) A repaired area not within 1/4 in. (6 mm) of the original dimensions.

Cracks greater than 0.007 in. (0.2 mm) in width shall be repaired with epoxy according to Section 590. For cracks less than or equal to 0.007 in. (0.2 mm) in width, the epoxy shall be applied to the surface of the crack as determined by the Engineer. Voids shall be repaired according to Article 503.15.

**532.12 Method of Measurement.** This work will be measured for payment in place and the area computed in square feet (square meters). For a repair at a corner, both sides will be measured.

**532.13 Basis of Payment.** This work will be paid for at the contract unit price per square foot (square meter) for STRUCTURAL REPAIR OF CONCRETE (DEPTH GREATER THAN 5 INCHES or STRUCTURAL REPAIR OF CONCRETE (DEPTH EQUAL TO OR LESS THAN 5 INCHES.

Concrete protected according to Article 1020.13(d) will be paid according to Article 503.22.

When not specified to be paid for elsewhere, the work to design, install, and remove the temporary shoring and cribbing will be paid according to Article 109.04.

With the exception of reinforcement damaged by the Contractor, supplemental reinforcement bars, mechanical bar splicers, hook bolts, and protective coat will be paid according to Article 109.04.”

**TEMPORARY CONCRETE BARRIER (BDE)**

Effective: January 1, 2026

Add the following to Article 704.02 of the Standard Specifications:

“(f) Type C Reflector .....1097.02(c)”

80481

## **SUBMISSION OF PAYROLL RECORDS – FEDERAL AID CONTRACT (BDE)**

Effective: April 1, 2026

If the prevailing rate of wages published by the Illinois Department of Labor (IDOL) is equal to or greater than the prevailing wage determination by the United States Secretary of Labor for the same locality for the same type of construction used to classify the federal construction project, the requirements of the Illinois Prevailing Wage Act (820 ILCS 130) shall apply, including the “ILLINOIS PREVAILING WAGE ACT” section below. If not, only the requirements of the Davis-Bacon Act shall apply, including the “DAVIS-BACON ACT” section below.

DAVIS-BACON ACT. Revise the following section of Check Sheet #1 of the Recurring Special Provisions to read:

### “STATEMENTS AND PAYROLLS

The payroll records shall include the worker’s name, social security number, last known address, telephone number, email address, classification(s) of work actually performed, hourly rates of wages paid (including rates of contributions or costs anticipated for bona fide fringe benefits or cash equivalents thereof), daily and weekly number of hours actually worked in total, deductions made, and actual wages paid.

The Contractor and each subcontractor shall submit certified payroll records to the Department each week from the start to the completion of their respective work, except that full social security numbers, last known addresses, telephone numbers, and email addresses shall not be included on weekly submittals. Instead, the payrolls need only include an identification number for each employee (e.g., the last four digits of the employee’s social security number). The submittals shall be made using LCPTracker Pro software. The software is web-based and can be accessed at <https://lcptracker.com/>. When there has been no activity during a work week, a payroll record shall still be submitted with the appropriate option (“No Work”, “Suspended”, or “Complete”) selected.”

ILLINOIS PREVAILING WAGE ACT. Revise the following section of Check Sheet #1 of the Recurring Special Provisions to read:

### “STATEMENTS AND PAYROLLS

- (1) Prevailing Wages. All wages paid by the Contractor and each subcontractor shall be in compliance with The Prevailing Wage Act (820 ILCS 130), as amended, except where a prevailing wage violates a federal law, order, or ruling, the rate conforming to the federal law, order, or ruling shall govern. The Contractor shall be responsible to notify each subcontractor of the wage rates set forth in this contract and any revisions thereto. If the Department of Labor revises the wage rates, the Contractor will not be allowed additional compensation on account of said revisions.

- (2) Payroll Records. The Contractor and each subcontractor shall make and keep, for a period of five years from the later of the date of final payment under the contract or completion of the contract, records of the wages paid to his/her workers. The payroll records shall include the worker's name, the worker's address, the worker's telephone number when available, the worker's social security number, the worker's classification or classifications, the worker's gross and net wages paid in each pay period, the worker's number of hours worked each day, and the worker's starting and ending times of work each day. However, any Contractor or subcontractor who remits contributions to a fringe benefit fund that is not jointly maintained and jointly governed by one or more employer and one or more labor organization must additionally submit the worker's hourly wage rate, the worker's hourly overtime wage rate, the worker's hourly fringe benefit rates, the name and address of each fringe benefit fund, the plan sponsor of each fringe benefit, if applicable, and the plan administrator of each fringe benefit, if applicable. Upon seven business days' notice, these records shall be available at a location within the State, during reasonable hours, for inspection by the Department or the Department of Labor; and Federal, State, or local law enforcement agencies and prosecutors.
- (3) Submission of Payroll Records. The Contractor and each subcontractor shall, no later than the 15<sup>th</sup> day of each calendar month, file a certified payroll for the immediately preceding month to the Illinois Department of Labor (IDOL) through the Certified Transcript of Payroll Portal in compliance with the State Prevailing Wage Act (820 ILCS 130). The portal can be found on the IDOL website at <https://labor.illinois.gov>. Payrolls shall be submitted in the format prescribed by the IDOL.

In addition to filing certified payroll(s) with the IDOL, the Contractor and each subcontractor shall certify and submit payroll records to the Department each week from the start to the completion of their respective work, except that full social security numbers shall not be included on weekly submittals. Instead, the payrolls shall include an identification number for each employee (e.g., the last four digits of the employee's social security number). In addition, starting and ending times of work each day may be omitted from the payroll records submitted. The submittals shall be made using LCPtracker Pro software. The software is web-based and can be accessed at <https://lcptracker.com/>. When there has been no activity during a work week, a payroll record shall still be submitted with the appropriate option ("No Work", "Suspended", or "Complete") selected.

- (4) Employee Interviews. The Contractor and each subcontractor shall permit his/her employees to be interviewed on the job, during working hours, by compliance investigators of the Department or the Department of Labor."

## INLET FILTERS

Effective: April 1, 2026

Revise the first paragraph of Article 1081.15(h) of the Standard Specifications to read:

“(h) Inlet Filters. An inlet filter shall consist of a steel frame with a two piece geotextile fabric bag or a single reinforced geotextile fabric bag attached with a stainless steel band and locking cap that is suspended from the frame. A clean, used bag and a used steel frame in good condition meeting the approval of the Engineer may be substituted for new materials. Materials for the inlet filter assembly shall be according to the following.”

Revise Article 1081.15(h)(3) of the Standard Specifications to read:

“(3) Geotextile Fabric Bag. The sediment bag shall have a minimum silt and debris capacity of 2.0 cu ft (0.06 cu m). The sediment bag shall also meet one of the following options.

- a. OPTION 1. Two piece geotextile fabric bag.

The inner filter bag shall be constructed of a polypropylene geotextile fabric according to the following.

Inner Filter Bag		
Material Property	Test Method	Minimum Average Roll Value
Grab Tensile Strength	ASTM D 4632	100 lb (45 kg)
Grab Tensile Elongation	ASTM D 4632	50%
Puncture Strength	ASTM D 4833/ ASTM D 6241	65 lb (29 kg)
Trapezoidal Tear	ASTM D 4533	45 lb (20 kg)
UV Resistance	ASTM D 4355	70% at 500 hours
Apparent Opening Size	ASTM D 4751	No. 70 (212 µm) sieve
Permittivity	ASTM D 4491	2.0/sec
Water Flow Rate	ASTM D 4491	145 gpm/sq ft (5900 Lpm/sq m)

The outer reinforcement bag shall be constructed of a polyester mesh material according to the following.

Outer Reinforcement Bag		
Material Property	Test Method	Value
Content	ASTM D 629	Polyester
Weight	ASTM D 3776	4.55 oz/sq yd (155 g/sq m) ± 15%
Apparent Opening Size	ASTM D 4751	No. 30 (600 µm) sieve
Water Flow Rate	ASTM D 4491	225 gpm/sq ft (9150 Lpm/sq m)
Burst	ASTM D 3786/ ASTM D 3787	120 psi (830 kPa) min.
Thickness	ASTM D 1777	0.040 ± 0.0050 in. (1.0 ± 0.1 mm)

b. OPTION 2. Reinforced geotextile fabric bag.

The filter bag shall be constructed of a polypropylene geotextile fabric reinforced with continuous filament fiberglass according to the following.

Reinforced Filter Bag		
Material Property	Test Method	Value or Minimum Average Roll Value
Weight	ASTM D 3776	5.00 oz/sq yd (170 g/sq m) ± 15%
Grab Tensile Strength	ASTM D 4632	200 lb (90 kg)
Grab Tensile Elongation	ASTM D 4632	50%
Puncture Strength	ASTM D 4833/ ASTM D 6241	95 lb (42 kg)
Trapezoidal Tear	ASTM D 4533	70 lb (31 kg)
Burst Strength	ASTM D 3786/ ASTM D 3787	325 psi (2240 kPa)
UV Resistance	ASTM D 4355	70% at 500 hours
Apparent Opening Size	ASTM D 4751	No. 70 (212 µm) sieve
Permittivity	ASTM D 4491	2.0/sec
Water Flow Rate	ASTM D 4491	145 gpm/sq ft (5900 Lpm/sq m)

- (4) Certification. The manufacturer shall furnish a certification with each shipment of inlet filters, stating the amount of product furnished and that the material complies with these requirements.”

## **COMPENSABLE DELAY COSTS (BDE)**

Effective: June 2, 2017

Revised: April 1, 2019

Revise Article 107.40(b) of the Standard Specifications to read:

“(b) Compensation. Compensation will not be allowed for delays, inconveniences, or damages sustained by the Contractor from conflicts with facilities not meeting the above definition; or if a conflict with a utility in an unanticipated location does not cause a shutdown of the work or a documentable reduction in the rate of progress exceeding the limits set herein. The provisions of Article 104.03 notwithstanding, compensation for delays caused by a utility in an unanticipated location will be paid according to the provisions of this Article governing minor and major delays or reduced rate of production which are defined as follows.

- (1) Minor Delay. A minor delay occurs when the work in conflict with the utility in an unanticipated location is completely stopped for more than two hours, but not to exceed two weeks.
- (2) Major Delay. A major delay occurs when the work in conflict with the utility in an unanticipated location is completely stopped for more than two weeks.
- (3) Reduced Rate of Production Delay. A reduced rate of production delay occurs when the rate of production on the work in conflict with the utility in an unanticipated location decreases by more than 25 percent and lasts longer than seven calendar days.”

Revise Article 107.40(c) of the Standard Specifications to read:

“(c) Payment. Payment for Minor, Major, and Reduced Rate of Production Delays will be made as follows.

- (1) Minor Delay. Labor idled which cannot be used on other work will be paid for according to Article 109.04(b)(1) and (2) for the time between start of the delay and the minimum remaining hours in the work shift required by the prevailing practice in the area.

Equipment idled which cannot be used on other work, and which is authorized to standby on the project site by the Engineer, will be paid for according to Article 109.04(b)(4).

- (2) Major Delay. Labor will be the same as for a minor delay.

Equipment will be the same as for a minor delay, except Contractor-owned equipment will be limited to two weeks plus the cost of move-out to either the

Contractor's yard or another job and the cost to re-mobilize, whichever is less. Rental equipment may be paid for longer than two weeks provided the Contractor presents adequate support to the Department (including lease agreement) to show retaining equipment on the job is the most economical course to follow and in the public interest.

- (3) Reduced Rate of Production Delay. The Contractor will be compensated for the reduced productivity for labor and equipment time in excess of the 25 percent threshold for that portion of the delay in excess of seven calendar days. Determination of compensation will be in accordance with Article 104.02, except labor and material additives will not be permitted.

Payment for escalated material costs, escalated labor costs, extended project overhead, and extended traffic control will be determined according to Article 109.13."

Revise Article 108.04(b) of the Standard Specifications to read:

"(b) No working day will be charged under the following conditions.

- (1) When adverse weather prevents work on the controlling item.
- (2) When job conditions due to recent weather prevent work on the controlling item.
- (3) When conduct or lack of conduct by the Department or its consultants, representatives, officers, agents, or employees; delay by the Department in making the site available; or delay in furnishing any items required to be furnished to the Contractor by the Department prevents work on the controlling item.
- (4) When delays caused by utility or railroad adjustments prevent work on the controlling item.
- (5) When strikes, lock-outs, extraordinary delays in transportation, or inability to procure critical materials prevent work on the controlling item, as long as these delays are not due to any fault of the Contractor.
- (6) When any condition over which the Contractor has no control prevents work on the controlling item."

Revise Article 109.09(f) of the Standard Specifications to read:

"(f) Basis of Payment. After resolution of a claim in favor of the Contractor, any adjustment in time required for the work will be made according to Section 108. Any adjustment in the costs to be paid will be made for direct labor, direct materials, direct equipment, direct jobsite overhead, direct offsite overhead, and other direct costs allowed by the resolution. Adjustments in costs will not be made for interest charges, loss of anticipated profit, undocumented loss of efficiency, home office overhead and unabsorbed overhead

other than as allowed by Article 109.13, lost opportunity, preparation of claim expenses and other consequential indirect costs regardless of method of calculation.

The above Basis of Payment is an essential element of the contract and the claim cost recovery of the Contractor shall be so limited.”

Add the following to Section 109 of the Standard Specifications.

**“109.13 Payment for Contract Delay.** Compensation for escalated material costs, escalated labor costs, extended project overhead, and extended traffic control will be allowed when such costs result from a delay meeting the criteria in the following table.

Contract Type	Cause of Delay	Length of Delay
Working Days	Article 108.04(b)(3) or Article 108.04(b)(4)	No working days have been charged for two consecutive weeks.
Completion Date	Article 108.08(b)(1) or Article 108.08(b)(7)	The Contractor has been granted a minimum two week extension of contract time, according to Article 108.08.

Payment for each of the various costs will be according to the following.

- (a) Escalated Material and/or Labor Costs. When the delay causes work, which would have otherwise been completed, to be done after material and/or labor costs have increased, such increases will be paid. Payment for escalated material costs will be limited to the increased costs substantiated by documentation furnished by the Contractor. Payment for escalated labor costs will be limited to those items in Article 109.04(b)(1) and (2), except the 35 percent and 10 percent additives will not be permitted.
- (b) Extended Project Overhead. For the duration of the delay, payment for extended project overhead will be paid as follows.
  - (1) Direct Jobsite and Offsite Overhead. Payment for documented direct jobsite overhead and documented direct offsite overhead, including onsite supervisory and administrative personnel, will be allowed according to the following table.

Original Contract Amount	Supervisory and Administrative Personnel
Up to \$5,000,000	One Project Superintendent
Over \$ 5,000,000 - up to \$25,000,000	One Project Manager, One Project Superintendent or Engineer, and One Clerk
Over \$25,000,000 - up to \$50,000,000	One Project Manager, One Project Superintendent, One Engineer, and

	One Clerk
Over \$50,000,000	One Project Manager, Two Project Superintendents, One Engineer, and One Clerk

(2) Home Office and Unabsorbed Overhead. Payment for home office and unabsorbed overhead will be calculated as 8 percent of the total delay cost.

(c) Extended Traffic Control. Traffic control required for an extended period of time due to the delay will be paid for according to Article 109.04.

When an extended traffic control adjustment is paid under this provision, an adjusted unit price as provided for in Article 701.20(a) for increase or decrease in the value of work by more than ten percent will not be paid.

Upon payment for a contract delay under this provision, the Contractor shall assign subrogation rights to the Department for the Department's efforts of recovery from any other party for monies paid by the Department as a result of any claim under this provision. The Contractor shall fully cooperate with the Department in its efforts to recover from another party any money paid to the Contractor for delay damages under this provision."

## HOT-MIX ASPHALT (BDE)

Effective: January 1, 2024

Revised: January 1, 2025

Revise the first and second paragraphs of Articles 1030.06(c)(2) of the Standard Specifications to read:

“(2) Personnel. The Contractor shall provide a QC Manager who shall have overall responsibility and authority for quality control. This individual shall maintain active certification as a Hot-Mix Asphalt Level II technician.

In addition to the QC Manager, the Contractor shall provide sufficient personnel to perform the required visual inspections, sampling, testing, and documentation in a timely manner. Mix designs shall be developed by personnel with an active certification as a Hot-Mix Asphalt Level III technician. Technicians performing mix design testing and plant sampling/testing shall maintain active certification as a Hot-Mix Asphalt Level I technician. The Contractor may provide a technician trainee who has successfully completed the Department's "Hot-Mix Asphalt Trainee Course" to assist in the activities completed by a Hot-Mix Asphalt Level I technician for a period of one year after the course completion date. The Contractor may also provide a Gradation Technician who has successfully completed the Department's "Gradation Technician Course" to run gradation tests only under the supervision of a Hot-Mix Asphalt Level II Technician. The Contractor shall provide a Hot-Mix Asphalt Density Tester who has successfully completed the Department's "Nuclear Density Testing" course to run all nuclear density tests on the job site.”

Revise the second paragraph of Articles 1030.07(a)(11) and 1030.08(a)(9) of the Standard Specifications to read:

“When establishing the target density, the HMA maximum theoretical specific gravity ( $G_{mm}$ ) will be based on the running average of four available Department test results for that project. If less than four  $G_{mm}$  test results are available, an average of all available Department test results for that project will be used. The initial  $G_{mm}$  will be the last available Department test result from a QMP project. If there is no available Department test result from a QMP project, the Department mix design verification test result will be used as the initial  $G_{mm}$ .”

Revise Article 1030.09(g)(2) of the Standard Specifications to read:

“(2) The Contractor shall complete split verification sample tests listed in the Limits of Precision table in Article 1030.09(h)(1).”

In the Supplemental Specifications, replace the revision for the end of the third paragraph of Article 1030.09(h)(2) with the following:

“When establishing the target density, the HMA maximum theoretical specific gravity ( $G_{mm}$ ) will be the Department mix design verification test result.”

Revise the tenth paragraph of Article 1030.10 of the Standard Specifications to read:

“Production is not required to stop after a test strip has been constructed.”

80456

## **VEHICLE AND EQUIPMENT WARNING LIGHTS (BDE)**

Effective: November 1, 2021

Revised: November 1, 2022

Add the following paragraph after the first paragraph of Article 701.08 of the Standard Specifications:

“The Contractor shall equip all vehicles and equipment with high-intensity oscillating, rotating, or flashing, amber or amber-and-white, warning lights which are visible from all directions. In accordance with 625 ILCS 5/12-215, the lights may only be in operation while the vehicle or equipment is engaged in construction operations.”

80439

## WORK ZONE TRAFFIC CONTROL DEVICES (BDE)

Effective: March 2, 2020

Revised: January 1, 2025

Add the following to Article 701.03 of the Standard Specifications:

“(q) Temporary Sign Supports ..... 1106.02”

Revise the third paragraph of Article 701.14 of the Standard Specifications to read:

“For temporary sign supports, the Contractor shall provide a FHWA eligibility letter for each device used on the contract. The letter shall provide information for the set-up and use of the device as well as a detailed drawing of the device. The signs shall be supported within 20 degrees of vertical. Weights used to stabilize signs shall be attached to the sign support per the manufacturer’s specifications.”

Revise the first paragraph of Article 701.15 of the Standard Specifications to read:

“**701.15 Traffic Control Devices.** For devices that must meet crashworthiness standards, the Contractor shall provide a manufacturer’s self-certification or a FHWA eligibility letter for each Category 1 device and a FHWA eligibility letter for each Category 2 and Category 3 device used on the contract. The self-certification or letter shall provide information for the set-up and use of the device as well as a detailed drawing of the device.”

Revise the first six paragraphs of Article 1106.02 of the Standard Specifications to read:

“**1106.02 Devices.** Work zone traffic control devices and combinations of devices shall meet crashworthiness standards for their respective categories. The categories are as follows.

Category 1 includes small, lightweight, channelizing and delineating devices that have been in common use for many years and are known to be crashworthy by crash testing of similar devices or years of demonstrable safe performance. These include cones, tubular markers, plastic drums, and delineators, with no attachments (e.g. lights). Category 1 devices shall be MASH compliant.

Category 2 includes devices that are not expected to produce significant vehicular velocity change but may otherwise be hazardous. These include vertical panels with lights, barricades, temporary sign supports, and Category 1 devices with attachments (e.g. drums with lights). Category 2 devices shall be MASH compliant.

Category 3 includes devices that are expected to cause significant velocity changes or other potentially harmful reactions to impacting vehicles. These include crash cushions (impact attenuators), truck mounted attenuators, and other devices not meeting the definitions of Category 1 or 2. Category 3 devices manufactured after December 31, 2019 shall be MASH compliant. Category 3 devices manufactured on or before December 31, 2019, and compliant

with NCHRP 350, may be used on contracts let before December 31, 2029. Category 3 devices shall be crash tested for Test Level 3 or the test level specified.

Category 4 includes portable or trailer-mounted devices such as sign supports, speed feedback displays, arrow boards, changeable message signs, temporary traffic signals, and area lighting supports. It is preferable for Category 4 devices manufactured after December 31, 2019 to be MASH-16 compliant; however, there are currently no crash tested devices in this category, so it remains exempt from the NCHRP 350 or MASH compliance requirement.

For each type of device, when no more than one MASH compliant is available, an NCHRP 350 compliant device may be used, even if manufactured after December 31, 2019.”

Revise Articles 1106.02(g), 1106.02(k), and 1106.02(l) to read:

“(g) Truck Mounted/Trailer Mounted Attenuators. The attenuator shall be approved for use at Test Level 3. Test Level 2 may be used for normal posted speeds less than or equal to 45 mph.

(k) Temporary Water Filled Barrier. The water filled barrier shall be a lightweight plastic shell designed to accept water ballast and be on the Department’s qualified product list.

Shop drawings shall be furnished by the manufacturer and shall indicate the deflection of the barrier as determined by acceptance testing; the configuration of the barrier in that test; and the vehicle weight, velocity, and angle of impact of the deflection test. The Engineer shall be provided one copy of the shop drawings.

(l) Movable Traffic Barrier. The movable traffic barrier shall be on the Department’s qualified product list.

Shop drawings shall be furnished by the manufacturer and shall indicate the deflection of the barrier as determined by acceptance testing; the configuration of the barrier in that test; and the vehicle weight, velocity, and angle of impact of the deflection test. The Engineer shall be provided one copy of the shop drawings. The barrier shall be capable of being moved on and off the roadway on a daily basis.”

**WORKING DAYS (BDE)**

Effective: January 1, 2002

The Contractor shall complete the work within **30** working days.

80071

Municipal Operation Sheet

Princeton 2026 General Fund Street Program

Location			Surface				Plan Quantities								
Street	From	To	Type	Length	Width	Area (SY)	SY	SY	LBS	TON	TON	EA	EA	EA	
Vernon St	Washington	Central	HMA	1,255	30	4,525	4,525	0	3,054.0	380.0	285.0	2	6	1	
Euclid Ave	Central	Peru	HMA	690	30	2,780	0	0	0.0	0.0	0.0	0	0	0	
Elm Lawn Cem			HMA			7,345	0	210	4,958.0	617.0	463.0	0	0	0	
<b>TOTALS</b>				1,945		14,650	4,525	210	8,012	997	748	2	6	1	

HMA Surf. Rem., Cold Mill - 2-1/4"	HMA Surf. Rem., Butt-Joint	Bit. Mtls., Tack Coat	HMA Binder Cse. IL 9.50, N50	Bit. Hot Mix Sand Seal Coat	Manhole to be Adj., Special	Inlet to be Adj., Special	Valve Box to be Adj., Special
------------------------------------	----------------------------	-----------------------	------------------------------	-----------------------------	-----------------------------	---------------------------	-------------------------------



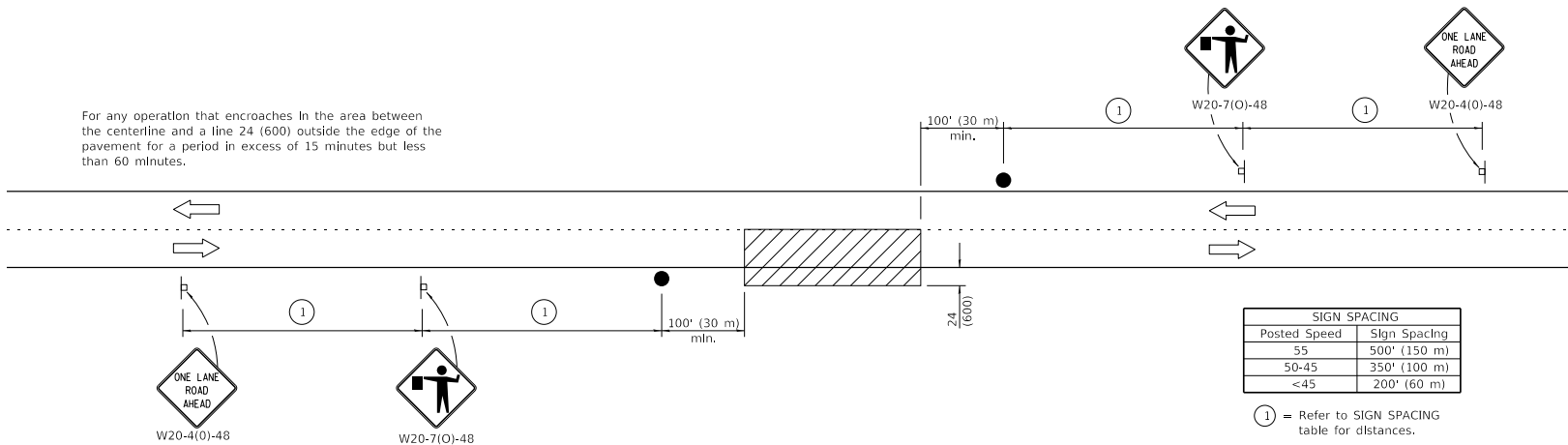
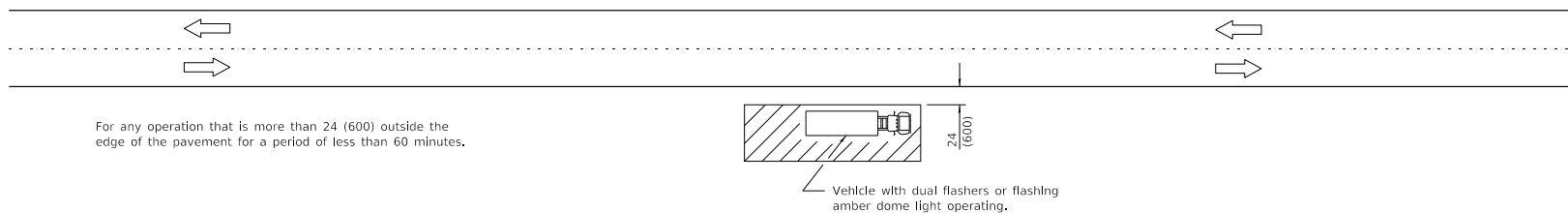
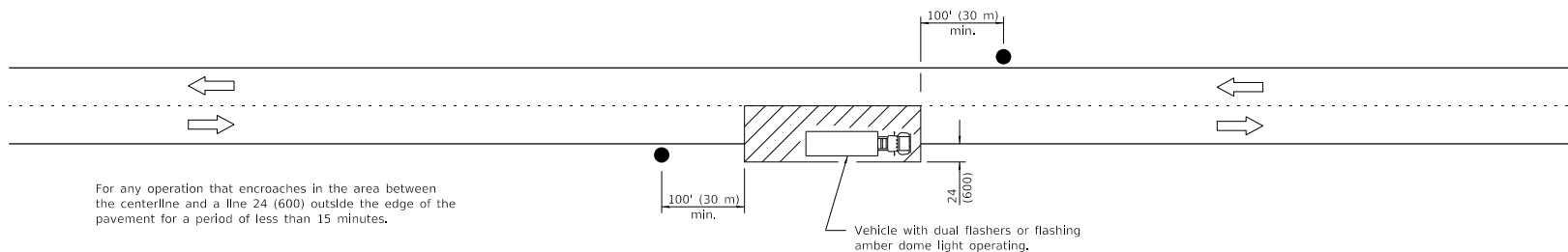

**TYPICAL APPLICATIONS**

- Marking patches
- Field survey
- String line
- Utility operations
- Cleaning up debris on pavement

**SYMBOLS**

- Work area
- Sign on portable or permanent support
- Flagger with traffic control sign

All dimensions are in inches (millimeters) unless otherwise shown.

Illinois Department of Transportation

PASSED January 1, 2011  
 ENGINEER OF SAFETY ENGINEERING

APPROVED January 1, 2011  
 ENGINEER OF DESIGN AND ENVIRONMENT

48-P-1 (REVISED)

DATE	REVISIONS
1-1-11	Revised flagger sign.
1-1-09	Switched units to English (metric).

**LANE CLOSURE, 2L, 2W, SHORT TIME OPERATIONS**

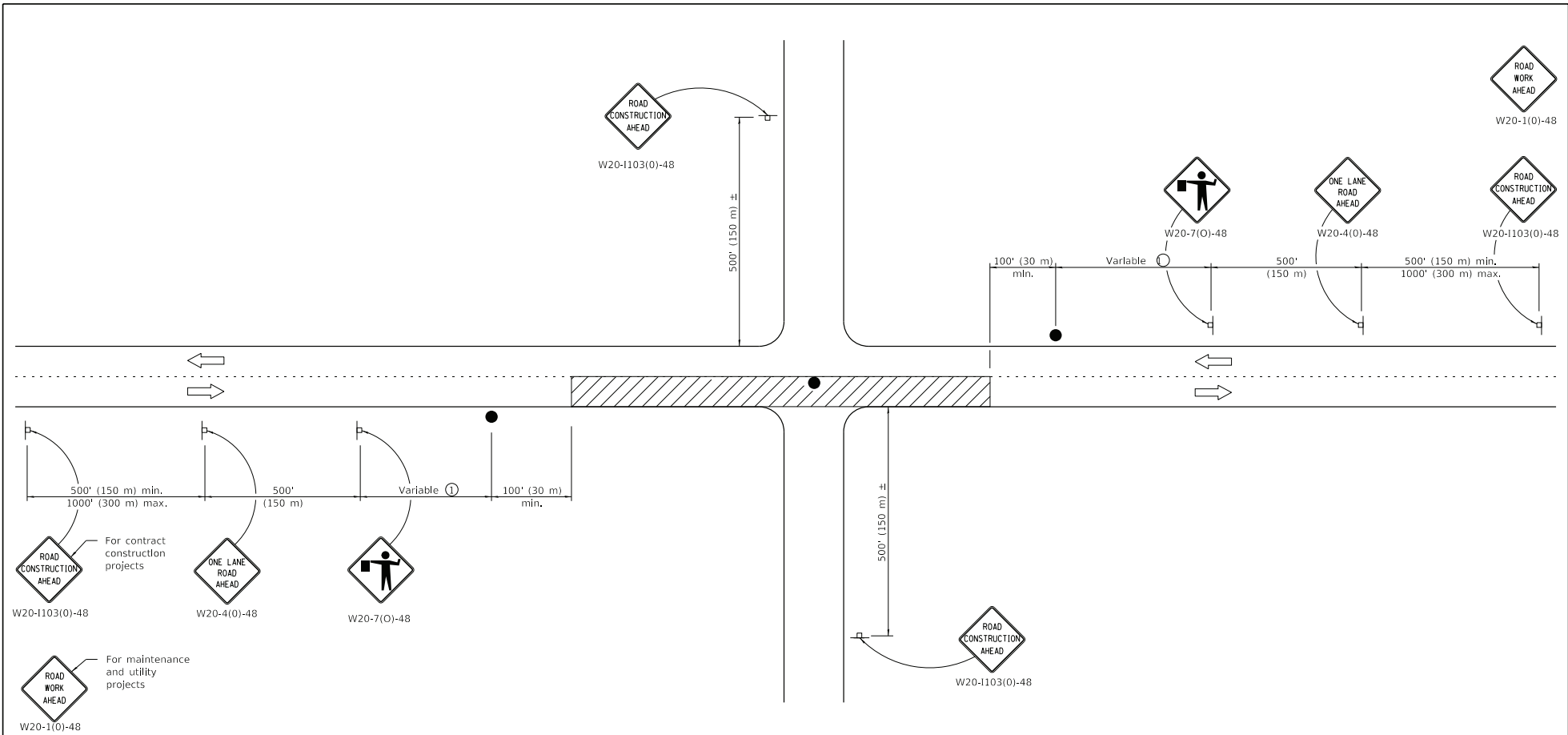

**STANDARD 701301-04**



**TYPICAL APPLICATIONS**

Bituminous resurfacing  
 Milling operations  
 Utility operations  
 Shoulder operations

**SYMBOLS**

-  Work area
-  Sign on portable or permanent support
-  Flagger with traffic control sign

① Minimum distance is 200' (60 m). Maximum distance to be determined by the Engineer but should not exceed 1/2 the length required for one normal working day's operation or 2 miles (3200 m), whichever is less.

**GENERAL NOTES**

This Standard is used where at any time, any vehicle, equipment, workers or their activities require an intermittent or continuous moving operation on the pavement where the average speed of movement is greater than 1/2 mph (1 km/h) and less than 4 mph (6 km/h).

When the operation does not exceed 60 minutes, traffic control may be according to Standard 701301.

All dimensions are in Inches (millimeters) unless otherwise shown.

DATE	REVISIONS
1-1-18	Revised lower speed limit for operation to 1/2 mph.
1-1-11	Revised flagger sign.

**LANE CLOSURE, 2L, 2W, SLOW MOVING OPERATIONS DAY ONLY, FOR SPEEDS ≥ 45 MPH**

**STANDARD 701306-04**

Illinois Department of Transportation

PASSED January 1, 2018  
 ENGINEER OF SAFETY, PROG. AND ENGINEERING

APPROVED January 1, 2018  
 ENGINEER OF DESIGN AND ENVIRONMENT

ISSUED 1-1-17

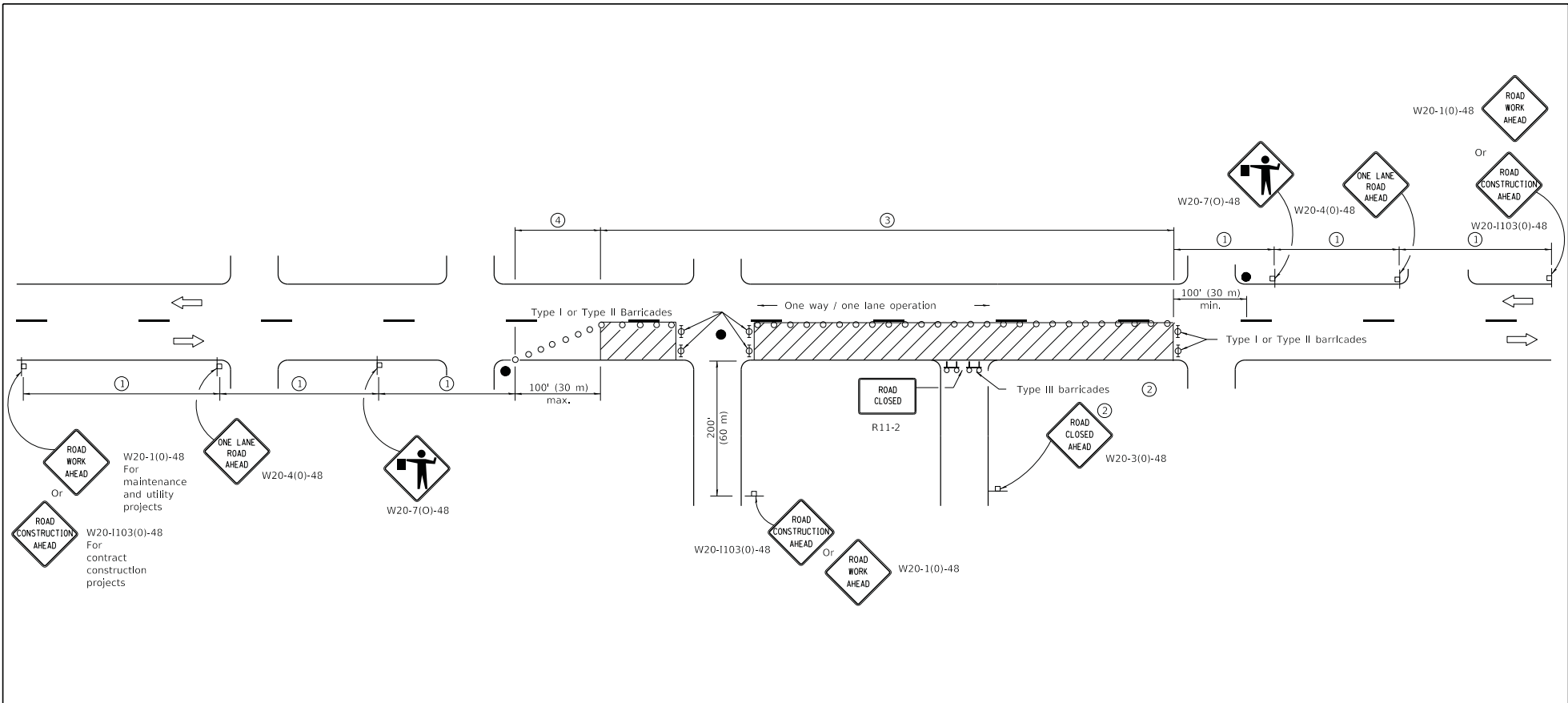

SIGN SPACING	
Posted Speed	Sign Spacing
55	500' (150 m)
50-45	350' (100 m)
<45	200' (60 m)

**SYMBOLS**

- Work area
- Cone, drum or barricade (not required for moving operations)
- Sign on portable or permanent support
- Flagger with traffic control sign
- Barricade or drum with flashing light
- Type III barricade with flashing lights

- ① Refer to SIGN SPACING TABLE for distances.
- ② For approved sideroad closures.
- ③ Cones at 25' (8 m) centers for 250' (75 m). Additional cones may be placed at 50' (15 m) centers. When drums or Type I or Type II barricades are used, the interval between devices may be doubled.
- ④ Cones, drums or barricades at 20' (6 m) centers.

**GENERAL NOTES**

This Standard is used where at any time, day or night, any vehicle, equipment, workers or their activities encroach on the pavement requiring the closure of one traffic lane in an urban area.

All dimensions are in inches (millimeters) unless otherwise shown.

Illinois Department of Transportation

PASSED January 1, 2011  
*Amber O'Neil*  
 ENGINEER OF SAFETY ENGINEERING

APPROVED January 1, 2011  
*Scott H. ...*  
 ENGINEER OF DESIGN AND ENVIRONMENT

ISSUED 1-1-11

DATE	REVISIONS
1-1-11	Revised flagger sign.
1-1-09	Switched units to English (metric).
	Corrected sign No.'s.

**URBAN LANE CLOSURE,  
2L, 2W, UNDIVIDED**

**STANDARD 701501-06**

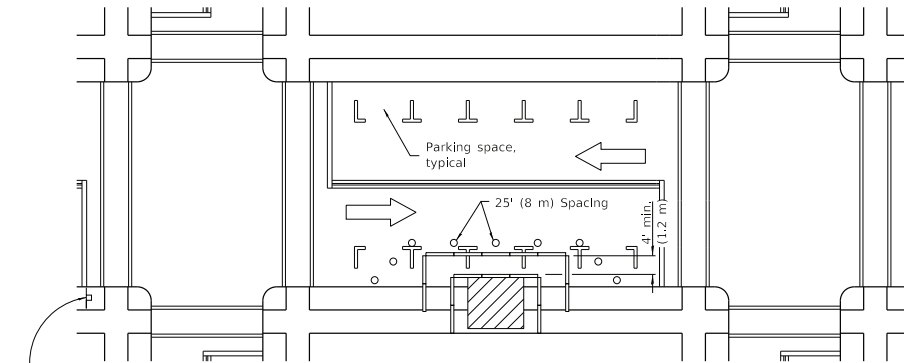

① ROAD CONSTRUCTION AHEAD  
W20-1103(0)-48 for contract construction projects

Or

① ROAD WORK AHEAD  
W20-1(0)-48 for maintenance and utility projects

**SIDEWALK DIVERSION**

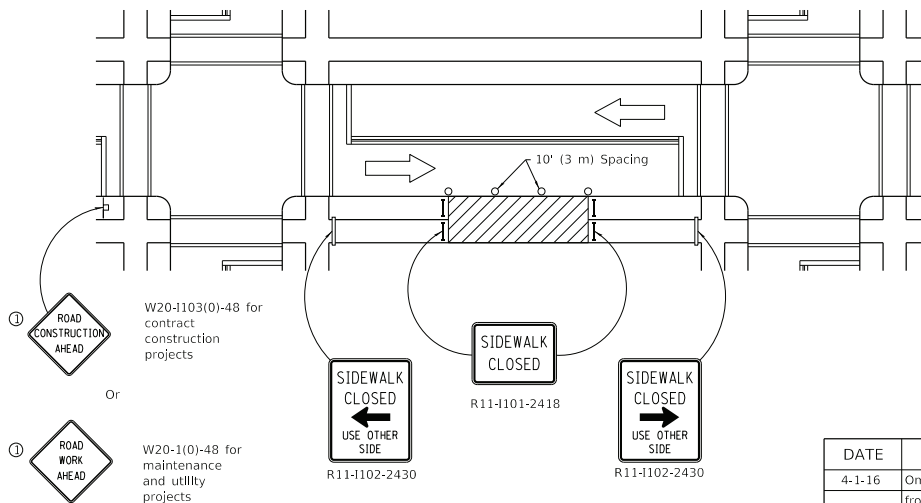

① ROAD CONSTRUCTION AHEAD  
W20-1103(0)-48 for contract construction projects

Or

① ROAD WORK AHEAD  
W20-1(0)-48 for maintenance and utility projects

**SIDEWALK CLOSURE**

① Omit whenever duplicated by road work traffic control.

**SYMBOLS**

- Work area
- Sign on portable or permanent support
- Barricade or drum
- Cone, drum or barricade
- Type III barricade
- Detectable pedestrian channelizing barricade

**GENERAL NOTES**

This Standard is used where, at any time, pedestrian traffic must be rerouted due to work being performed.

This Standard must be used in conjunction with other Traffic Control & Protection Standards when roadway traffic is affected.

Temporary facilities shall be detectable and accessible.

The temporary pedestrian facilities shall be provided on the same side of the closed facilities whenever possible.

The SIDEWALK CLOSED / USE OTHER SIDE sign shall be placed at the nearest crosswalk or intersection to each end of the closure. Where the closure occurs at a corner, the signs shall be erected on the corners across the street from the closure. The SIDEWALK CLOSED signs shall be used at the ends of the actual closures.

Type III barricades and R11-2-4830 signs shall be positioned as shown in "ROAD CLOSED TO ALL TRAFFIC" detail on Standard 701901.

All dimensions are in inches (millimeters) unless otherwise shown.

DATE	REVISIONS
4-1-16	Omitted orange safety fence from standard as this is covered in the std. spec.
1-1-12	Added SIDEWALK DIVERSION. Modified appearance of plan views. Renamed Std.

**SIDEWALK, CORNER OR CROSSWALK CLOSURE**

(Sheet 1 of 2)

**STANDARD 701801-06**

Illinois Department of Transportation

PASSED *[Signature]* April 1, 2016  
ENGINEER OF SAFETY ENGINEERING

APPROVED *[Signature]* April 1, 2016  
ENGINEER OF DESIGN AND ENVIRONMENT

ISSUED 1-1-17

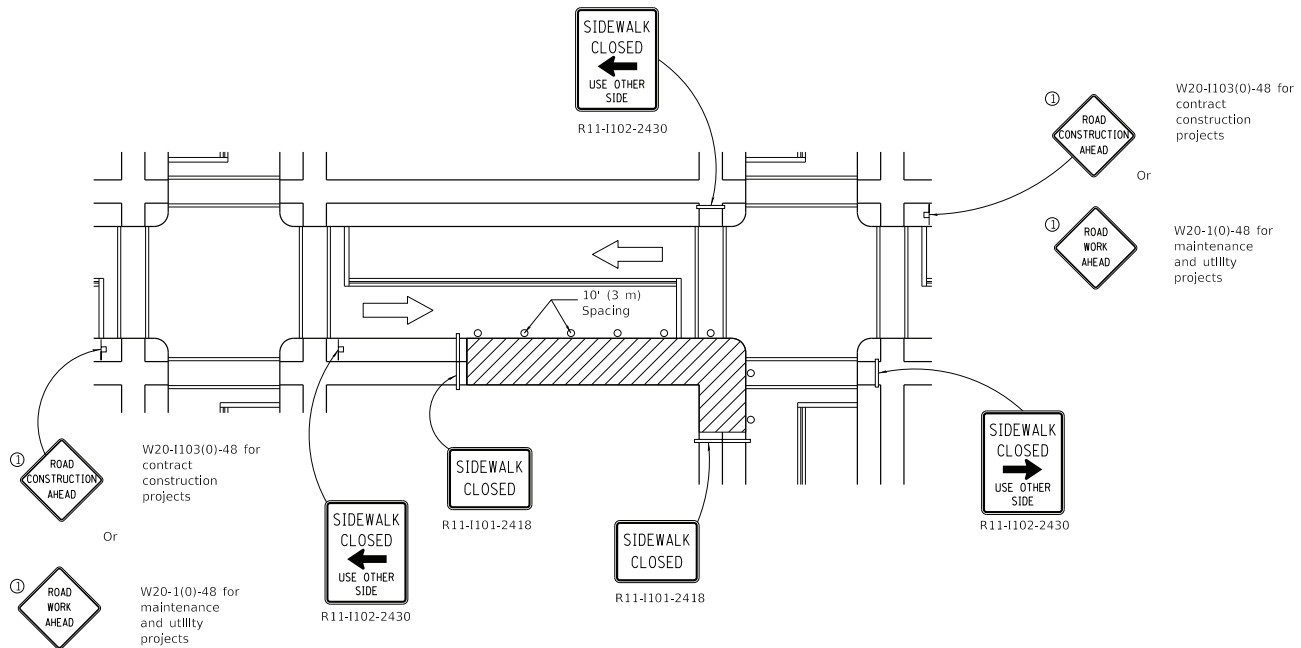

**CORNER CLOSURE**

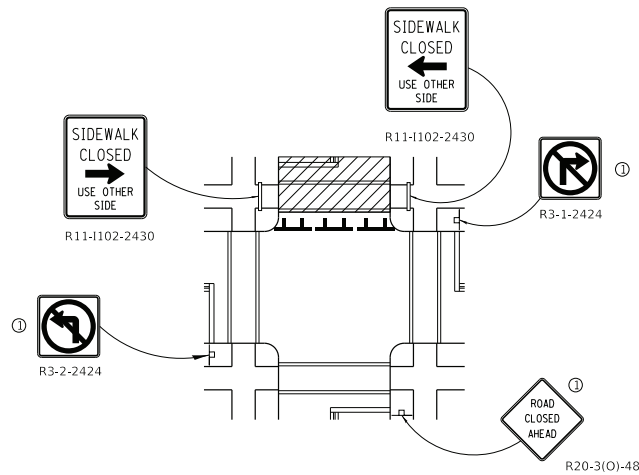

**CROSSWALK CLOSURE**

Illinois Department of Transportation

PASSED *[Signature]* April 1, 2016  
 ENGINEER OF SAFETY ENGINEERING

APPROVED *[Signature]* April 1, 2016  
 ENGINEER OF DESIGN AND ENVIRONMENT

ISSUED 1-1-97

**SIDEWALK, CORNER OR CROSSWALK CLOSURE**

(Sheet 2 of 2)

**STANDARD 701801-06**

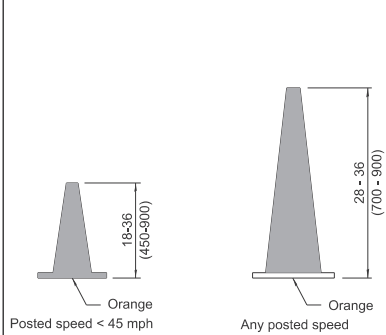

**DAYTIME USE**

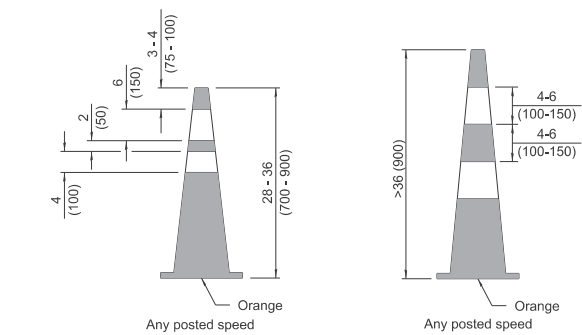

**DAY OR NIGHTTIME USE**

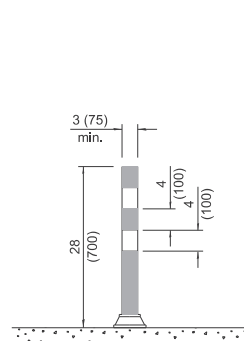

**TUBULAR MARKER**

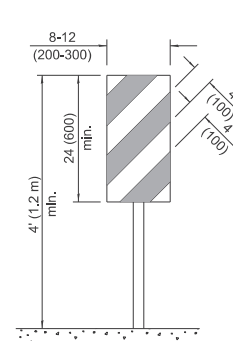

**VERTICAL PANEL  
POST MOUNTED**

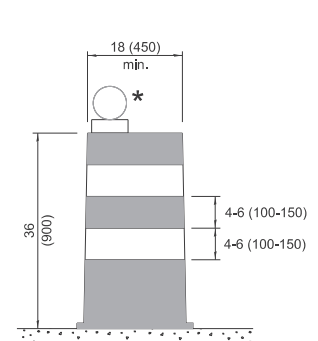

**DRUM**

**CONES**

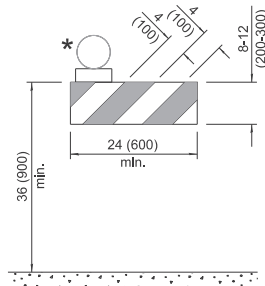

**TYPE I BARRICADE**

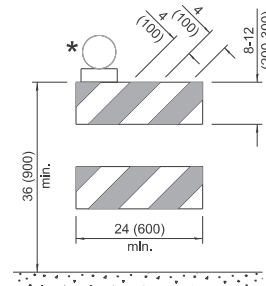

**TYPE II BARRICADE**

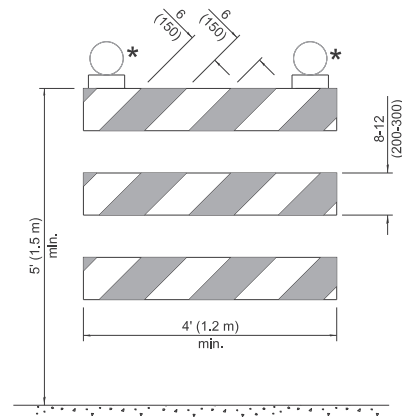

**TYPE III BARRICADE**

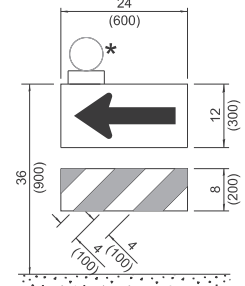

**DIRECTION INDICATOR  
BARRICADE**

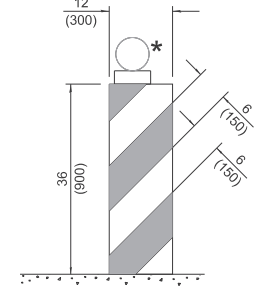

**VERTICAL BARRICADE**

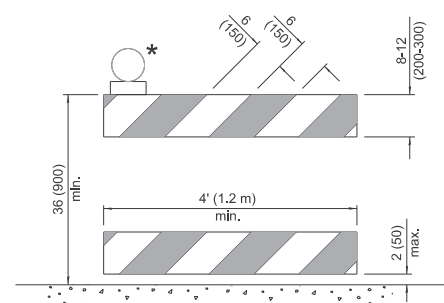

**DETECTABLE PEDESTRIAN  
CHANNELIZING BARRICADE**

\* Warning Lights (If required)

**GENERAL NOTES**

All heights shown shall be measured above the pavement surface.

All dimensions are in inches (millimeters) unless otherwise shown.

Illinois Department of Transportation

APPROVED January 1, 2025

ENGINEER OF SAFETY PROS. AND ENGINEERING

APPROVED January 1, 2025

ENGINEER OF DESIGN AND ENVIRONMENT

DATE	REVISIONS
1-1-25	Updated Temporary Rumble Strip Detail (sht. 3).
1-1-24	Revised Type III Barricade notes (sht. 3) & moved warning light on post mounted signs to top center.

**TRAFFIC CONTROL  
DEVICES**

(Sheet 1 of 3)

**STANDARD 701901-10**

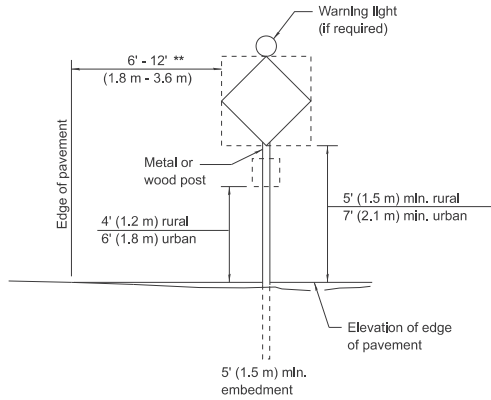

**POST MOUNTED SIGNS**

\*\* When curb or paved shoulder are present this dimension shall be 24 (600) to the face of curb or 6' (1.8 m) to the outside edge of the paved shoulder.

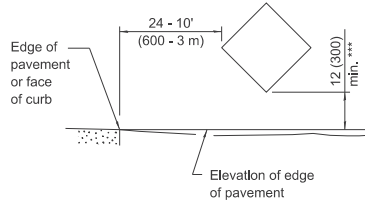

**SIGNS ON TEMPORARY SUPPORTS**

\*\*\* When work operations exceed four days, this dimension shall be 5' (1.5 m) min. If located behind other devices, the height shall be sufficient to be seen completely above the devices.

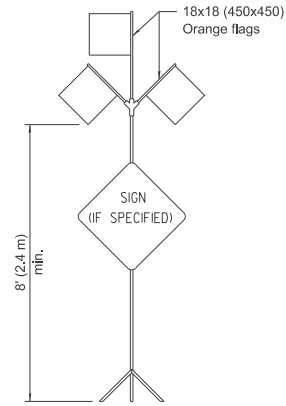

**HIGH LEVEL WARNING DEVICE**

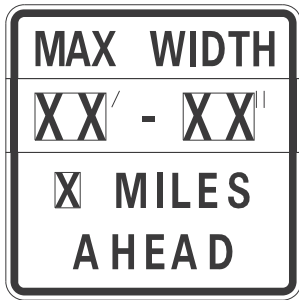

W12-1103-4848

**WIDTH RESTRICTION SIGN**

XX-XX" width and X miles are variable.

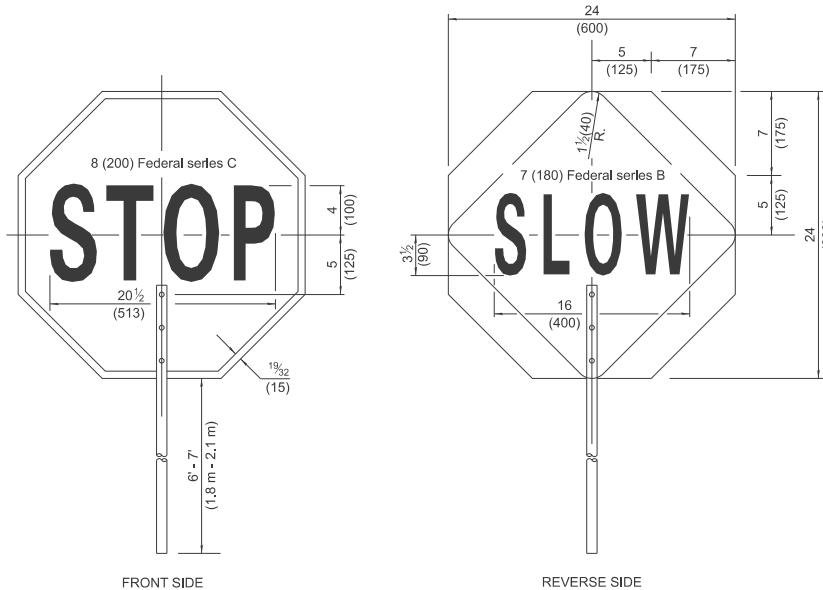

**FLAGGER TRAFFIC CONTROL SIGN**

ROAD CONSTRUCTION NEXT X MILES

END CONSTRUCTION

G20-1104(0)-6036

G20-1105(0)-6024

This signing is required for all projects 2 miles (3200 m) or more in length.

ROAD CONSTRUCTION NEXT X MILES sign shall be placed 500' (150 m) in advance of project limits.

END CONSTRUCTION sign shall be erected at the end of the job unless another job is within 2 miles (3200 m).

Dual sign displays shall be utilized on multi-lane highways.

**WORK LIMIT SIGNING**



W21-1115(0)-3618

R2-1-3648

R10-1108p-3618 \*\*\*\*

R2-1106p-3618

Sign assembly as shown on Standards or as allowed by District Operations.

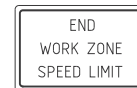

G20-1103-6036

This sign shall be used when the above sign assembly is used.

**HIGHWAY CONSTRUCTION SPEED ZONE SIGNS**

\*\*\*\* R10-1108p shall only be used along roadways under the jurisdiction of the State.

**TRAFFIC CONTROL DEVICES**

(Sheet 2 of 3)

STANDARD 701901-10

Illinois Department of Transportation

APPROVED January 1, 2025

ENGINEER OF SAFETY PROS. AND ENGINEERING

APPROVED January 1, 2025

ENGINEER OF DESIGN AND ENVIRONMENT

ISSUED 1-1-2025

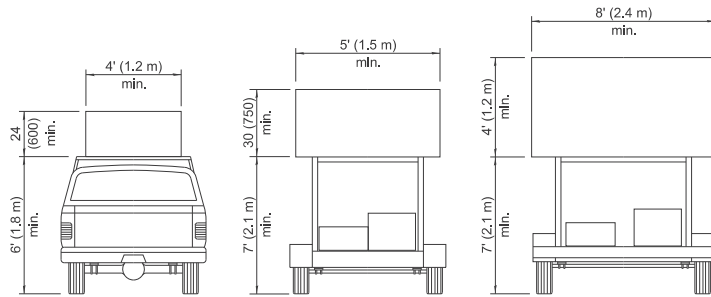

**TYPE A  
ROOF  
MOUNTED**

**TYPE B  
ROOF OR TRAILER  
MOUNTED**

**TYPE C  
TRAILER  
MOUNTED**

**ARROW BOARDS**

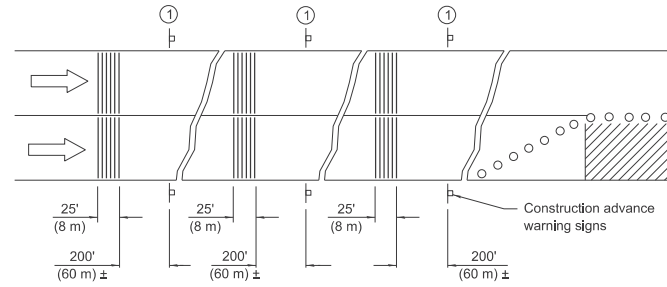

① This sign shall be omitted when median width is less than 10' (3 m).

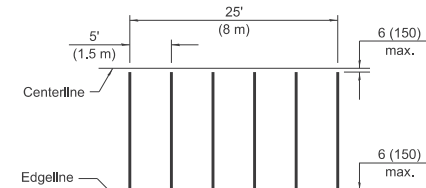

**TYPICAL INSTALLATION**

**TEMPORARY RUMBLE STRIPS**

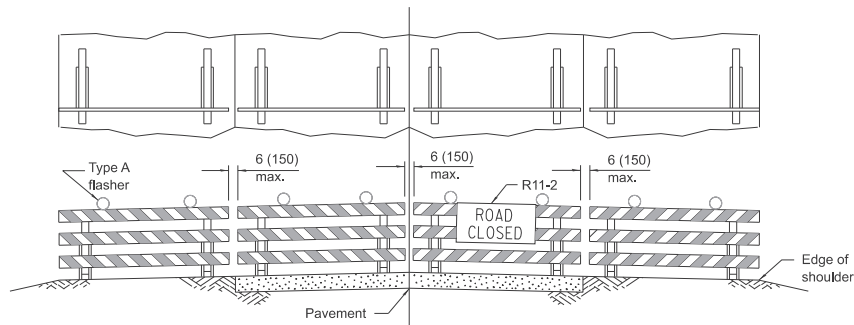

**ROAD CLOSED TO ALL TRAFFIC**  
 ReflectORIZED striping may be omitted on the back side of the barricades.

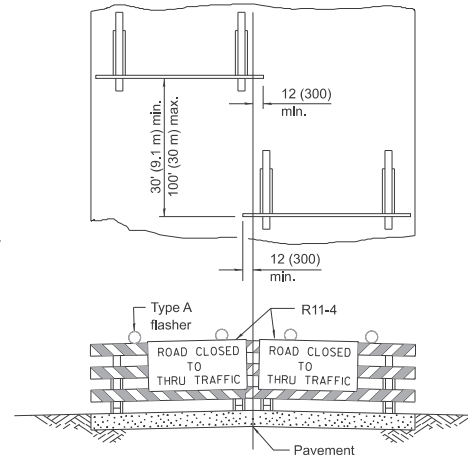

**ROAD CLOSED TO THRU TRAFFIC**  
 ReflectORIZED striping shall appear on both sides of the barricades.

**TYPICAL APPLICATIONS OF  
TYPE III BARRICADES CLOSING A ROAD**

If a Type III barricade with an attached sign panel which meets NCHRP 350 or MASH is not available, the sign may be mounted on an NCHRP 350 or MASH temporary sign support directly in front of the barricade.

**TRAFFIC CONTROL  
DEVICES**

(Sheet 3 of 3)

**STANDARD 701901-10**

Illinois Department of Transportation	
APPROVED January 1, 2025 ENGINEER OF SAFETY PROS. AND ENGINEERING APPROVED January 1, 2025 ENGINEER OF DESIGN AND ENVIRONMENT	ISSUED 1-1-1-1

## Bureau County Prevailing Wage Rates posted on 4/15/2026

Trade Title	Rg	Type	C	Base	Foreman	Overtime					Pension	Vac	Trng	Other Ins	Add OT 1.5x owed	Add OT 2.0x owed
						M-F	Sa	Su	Hol	H/W						
ASBESTOS ABT-GEN	All	ALL		42.54	44.54	1.5	1.5	2.0	2.0	9.75	21.87	0.00	0.80	0.00	3.75	7.50
ASBESTOS ABT-MEC	All	BLD		42.02	45.38	1.5	1.5	2.0	2.0	16.44	16.64	0.00	0.92		3.37	6.73
BOILERMAKER	All	BLD		50.46	54.46	1.5	1.5	2.0	2.0	7.07	24.29	0.00	2.34	0.00	16.38	32.76
BRICK MASON	All	BLD		45.01	46.01	1.5	1.5	2.0	2.0	12.86	18.63	0.00	1.33	0.00	0.00	0.00
CARPENTER	All	BLD		39.00	42.90	1.5	1.5	2.0	2.0	12.26	24.36	0.00	0.89		0.00	0.00
CARPENTER	All	HWY		40.28	42.03	1.5	1.5	2.0	2.0	12.89	25.12	0.00	0.94	0.00	0.00	0.00
CEMENT MASON	All	ALL		43.35	47.69	1.5	1.5	2.0	2.0	13.38	22.46	0.00	0.80	0.00	0.00	0.00
CERAMIC TILE FINISHER	All	BLD		41.66		1.5	1.5	2.0	2.0	12.45	14.27	0.00	1.25	0.00	0.00	0.00
COMMUNICATION TECHNICIAN	All	BLD		46.00	50.60	1.5	1.5	2.0	2.0	17.54	18.15	0.00	0.75	2.37	0.00	0.00
ELECTRIC PWR EQMT OP	All	ALL		59.91	71.10	1.5	1.5	2.0	2.0	9.30	16.78	0.00	0.60	0.00	0.00	0.00
ELECTRIC PWR GRNDMAN	All	ALL		40.71	71.10	1.5	1.5	2.0	2.0	8.72	11.40	0.00	0.41	0.00	0.00	0.00
ELECTRIC PWR LINEMAN	All	ALL		66.69	71.10	1.5	1.5	2.0	2.0	9.50	18.67	0.00	0.67	0.00	0.00	0.00
ELECTRIC PWR TRK DRV	All	ALL		45.45	71.10	1.5	1.5	2.0	2.0	8.86	12.72	0.00	0.45	0.00	0.00	0.00
ELECTRICIAN	All	BLD		54.45	59.35	1.5	1.5	2.0	2.0	18.13	22.88	0.00	1.35	5.40	0.00	0.00
ELEVATOR CONSTRUCTOR	All	BLD		56.30	63.34	2.0	2.0	2.0	2.0	16.28	21.36	4.50	0.80	0.00	0.00	0.00
GLAZIER	All	BLD		41.24	43.24	1.5	1.5	1.5	2.0	15.87	11.51	0.00	1.40	0.00	0.00	0.00
HEAT/FROST INSULATOR	All	BLD		56.02	59.38	1.5	1.5	2.0	2.0	16.44	19.88	0.00	0.92		4.99	9.97
IRON WORKER	All	ALL		49.40	54.34	2.0	2.0	2.0	2.0	14.61	26.15	0.00	1.10	0.00	0.00	0.00
LABORER	All	ALL		40.54	42.54	1.5	1.5	2.0	2.0	9.75	21.87	0.00	0.80	0.00	3.75	7.50
LABORER, SKILLED	All	ALL		40.54	42.54	1.5	1.5	2.0	2.0	9.75	21.87	0.00	0.80	0.00	3.75	7.50
LATHER	All	BLD		39.00	42.90	1.5	1.5	2.0	2.0	12.26	24.36	0.00	0.89		0.00	0.00
MACHINIST	All	BLD		60.39	64.39	1.5	1.5	2.0	2.0	11.43	9.95	1.85	1.47	0.00	0.00	0.00
MARBLE FINISHER	All	BLD		41.66		1.5	1.5	2.0	2.0	12.45	14.27	0.00	1.25	0.00	0.00	0.00
MARBLE MASON	All	BLD		45.01	46.01	1.5	1.5	2.0	2.0	12.45	15.90	0.00	1.30	0.00	0.00	0.00
MILLWRIGHT	All	BLD		51.09	56.20	1.5	1.5	2.0	2.0	12.53	20.25	0.00	0.83		0.00	0.00
OPERATING ENGINEER	E	BLD	1	63.00	67.00	2.0	2.0	2.0	2.0	24.70	21.55	2.00	2.75		0.00	0.00

## Bureau County Prevailing Wage Rates posted on 4/15/2026

OPERATING ENGINEER	E	BLD	2	61.70	67.00	2.0	2.0	2.0	2.0	24.70	21.55	2.00	2.75		0.00	0.00
OPERATING ENGINEER	E	BLD	3	59.15	67.00	2.0	2.0	2.0	2.0	24.70	21.55	2.00	2.75		0.00	0.00
OPERATING ENGINEER	E	BLD	4	57.40	67.00	2.0	2.0	2.0	2.0	24.70	21.55	2.00	2.75		0.00	0.00
OPERATING ENGINEER	E	BLD	5	65.00	67.00	2.0	2.0	2.0	2.0	24.70	21.55	2.00	2.75		0.00	0.00
OPERATING ENGINEER	E	BLD	6	66.00	67.00	2.0	2.0	2.0	2.0	24.70	21.55	2.00	2.75		0.00	0.00
OPERATING ENGINEER	E	BLD	7	64.00	67.00	2.0	2.0	2.0	2.0	24.70	21.55	2.00	2.75		0.00	0.00
OPERATING ENGINEER	E	HWY	1	63.00	67.00	1.5	1.5	2.0	2.0	24.70	21.55	2.00	2.75		0.00	0.00
OPERATING ENGINEER	E	HWY	2	62.45	67.00	1.5	1.5	2.0	2.0	24.70	21.55	2.00	2.75		0.00	0.00
OPERATING ENGINEER	E	HWY	3	60.40	67.00	1.5	1.5	2.0	2.0	24.70	21.55	2.00	2.75		0.00	0.00
OPERATING ENGINEER	E	HWY	4	59.00	67.00	1.5	1.5	2.0	2.0	24.70	21.55	2.00	2.75		0.00	0.00
OPERATING ENGINEER	E	HWY	5	57.80	67.00	1.5	1.5	2.0	2.0	24.70	21.55	2.00	2.75		0.00	0.00
OPERATING ENGINEER	E	HWY	6	66.00	67.00	1.5	1.5	2.0	2.0	24.70	21.55	2.00	2.75		0.00	0.00
OPERATING ENGINEER	E	HWY	7	64.00	67.00	1.5	1.5	2.0	2.0	24.70	21.55	2.00	2.75		0.00	0.00
OPERATING ENGINEER	W	BLD	1	47.79	50.79	1.5	1.5	2.0	2.0	12.85	26.97	0.00	3.60		0.00	0.00
OPERATING ENGINEER	W	BLD	2	44.09		1.5	1.5	2.0	2.0	12.85	26.97	0.00	3.60		0.00	0.00
OPERATING ENGINEER	W	BLD	3	38.03		1.5	1.5	2.0	2.0	12.85	26.97	0.00	3.60	0.00	0.00	0.00
OPERATING ENGINEER	W	HWY	1	47.79	51.29	1.5	1.5	2.0	2.0	12.85	26.97	0.00	3.60	0.00	0.00	0.00
OPERATING ENGINEER	W	HWY	2	44.09		1.5	1.5	2.0	2.0	12.85	26.97	0.00	3.60		0.00	0.00
OPERATING ENGINEER	W	HWY	3	38.03		1.5	1.5	2.0	2.0	12.85	26.97	0.00	3.60		0.00	0.00
PAINTER	All	ALL		42.40	44.40	1.5	1.5	1.5	2.0	15.45	12.00	0.00	1.50	0.00	0.00	0.00
PAINTER - SIGNS	All	BLD		48.16	54.11	1.5	1.5	2.0	2.0	8.20	16.81	0.00	0.00	0.00	0.00	0.00
PILEDRIIVER	All	BLD		39.25	43.18	1.5	1.5	2.0	2.0	12.26	24.36	0.00	0.89		0.00	0.00
PILEDRIIVER	All	HWY		41.28	43.03	1.5	1.5	2.0	2.0	12.89	25.12	0.00	0.94		0.00	0.00
PIPEFITTER	All	BLD		58.50	61.50	1.5	1.5	2.0	2.0	15.15	22.85	0.00	3.12	0.00	0.00	0.00
PLASTERER	All	BLD		43.35	47.69	1.5	1.5	2.0	2.0	13.38	22.46	0.00	0.80	0.00	0.00	0.00
PLUMBER	All	BLD		60.50	64.15	1.5	1.5	2.0	2.0	19.10	17.94	0.00	1.98		0.00	0.00
ROOFER	All	BLD		39.50	42.00	1.5	1.5	2.0	2.0	12.80	14.71	0.00	0.67	0.00	0.00	0.00
SHEETMETAL WORKER	All	BLD		50.36	53.89	1.5	1.5	2.0	2.0	12.42	24.15	0.00	1.34	0.00	0.00	0.00
SPRINKLER FITTER	All	BLD		50.51	53.76	1.5	1.5	2.0	2.0	12.40	17.31	0.00	0.54	0.00	0.00	0.00
STONE MASON	All	BLD		45.01	46.01	1.5	1.5	2.0	2.0	12.86	18.63	0.00	1.33	0.00	0.00	0.00

## Bureau County Prevailing Wage Rates posted on 4/15/2026

TERRAZZO FINISHER	All	BLD		41.66		1.5	1.5	2.0	2.0	12.45	14.27	0.00	1.25	0.00	0.00	0.00
TILE LAYER	All	BLD		39.00	42.90	1.5	1.5	2.0	2.0	12.26	24.36	0.00	0.89		0.00	0.00
TILE MASON	All	BLD		45.01	46.01	1.5	1.5	2.0	2.0	12.45	15.90	0.00	1.30	0.00	0.00	0.00
TRUCK DRIVER	All	ALL	1	45.29	49.65	1.5	1.5	2.0	2.0	17.11	8.06	0.00	0.25	0.00	0.00	0.00
TRUCK DRIVER	All	ALL	2	45.88	49.65	1.5	1.5	2.0	2.0	17.11	8.06	0.00	0.25	0.00	0.00	0.00
TRUCK DRIVER	All	ALL	3	46.15	49.65	1.5	1.5	2.0	2.0	17.11	8.06	0.00	0.25	0.00	0.00	0.00
TRUCK DRIVER	All	ALL	4	46.54	49.65	1.5	1.5	2.0	2.0	17.11	8.06	0.00	0.25	0.00	0.00	0.00
TRUCK DRIVER	All	ALL	5	47.64	49.65	1.5	1.5	2.0	2.0	17.11	8.06	0.00	0.25	0.00	0.00	0.00
TRUCK DRIVER	All	O&C	1	36.23	39.72	1.5	1.5	2.0	2.0	17.11	8.06	0.00	0.25	0.00	0.00	0.00
TRUCK DRIVER	All	O&C	2	36.70	39.72	1.5	1.5	2.0	2.0	17.11	8.06	0.00	0.25	0.00	0.00	0.00
TRUCK DRIVER	All	O&C	3	36.92	39.72	1.5	1.5	2.0	2.0	17.11	8.06	0.00	0.25	0.00	0.00	0.00
TRUCK DRIVER	All	O&C	4	37.23	39.72	1.5	1.5	2.0	2.0	17.11	8.06	0.00	0.25	0.00	0.00	0.00
TRUCK DRIVER	All	O&C	5	38.11	39.72	1.5	1.5	2.0	2.0	17.11	8.06	0.00	0.25	0.00	0.00	0.00
TUCK POINTER	All	BLD		45.01	46.01	1.5	1.5	2.0	2.0	12.86	18.63	0.00	1.33	0.00	0.00	0.00

### Legend

**Rg** Region

**Type** Trade Type - All,Highway,Building,Floating,Oil & Chip,Rivers

**C** Class

**Base** Base Wage Rate

**OT M-F** Unless otherwise noted, OT pay is required for any hour greater than 8 worked each day, Mon through Fri. The number listed is the multiple of the base wage.

**OT Sa** Overtime pay required for every hour worked on Saturdays

**OT Su** Overtime pay required for every hour worked on Sundays

**OT Hol** Overtime pay required for every hour worked on Holidays

**H/W** Health/Welfare benefit

**Vac** Vacation

**Trng** Training

**Other Ins** Employer hourly cost for any other type(s) of insurance provided for benefit of worker.

Explanations BUREAU COUNTY

OPERATING ENGINEERS (EAST) - That part of the county East of Route 26.

## **Bureau County Prevailing Wage Rates posted on 4/15/2026**

The following list is considered as those days for which holiday rates of wages for work performed apply: New Years Day, Memorial Day, Fourth of July, Labor Day, Thanksgiving Day, Christmas Day and Veterans Day in some classifications/counties. Generally, any of these holidays which fall on a Sunday is celebrated on the following Monday. This then makes work performed on that Monday payable at the appropriate overtime rate for holiday pay. Common practice in a given local may alter certain days of celebration. If in doubt, please check with IDOL.

Oil and chip resealing (O&C) means the application of road oils and liquid asphalt to coat an existing road surface, followed by application of aggregate chips or gravel to coated surface, and subsequent rolling of material to seal the surface.

### **EXPLANATION OF CLASSES**

ASBESTOS - GENERAL - removal of asbestos material/mold and hazardous materials from any place in a building, including mechanical systems where those mechanical systems are to be removed. This includes the removal of asbestos materials/mold and hazardous materials from ductwork or pipes in a building when the building is to be demolished at the time or at some close future date.

ASBESTOS - MECHANICAL - removal of asbestos material from mechanical systems, such as pipes, ducts, and boilers, where the mechanical systems are to remain.

### **CERAMIC TILE FINISHER, MARBLE FINISHER, TERRAZO FINISHER**

Assisting, helping or supporting the tile, marble and terrazzo mechanic by performing their historic and traditional work assignments required to complete the proper installation of the work covered by said crafts. The term "Ceramic" is used for naming the classification only and is in no way a limitation of the product handled. Ceramic takes into consideration most hard tiles.

### **COMMUNICATION TECHNICIAN**

Installation, operation, inspection, maintenance, repair and service of radio, television, recording, voice, sound and vision production and reproduction, telephone and telephone interconnect, facsimile, equipment and appliances used for domestic, commercial, educational and entertainment purposes, pulling of wire through conduit but not the installation of conduit.

### **LABORER, SKILLED - BUILDING AND HIGHWAY**

The skilled laborer building (BLD) and heavy & highway (HWY) classification shall encompass the following types of work, irrespective of the site of the work: flagging, caisson worker plus depth, gunnite nozzle men, lead man on sewer work, welders, cutter burners and torchmen, chain saw operator, paving breaker, jackhammer and drill operators, layout man and/or drainage tile layer, steel form setter - street and highway, air tamping hammerman, signal man on crane, concrete saw operator, concrete saw operator walk behind, screenman on asphalt pavers, front end man on chip spreader, laborers tending masons with hot material or where foreign materials are used, multiple concrete duct - leadman, luteman, asphalt raker, curb asphalt machine operator, ready mix scalemen (permanent, portable or temporary plant), laborers handling masterplate or similar materials, laser beam operator, coring machine operator, plaster tenders, underpinning and shoring of buildings, material selector when working with fire-brick or castable material, fire watch, signaling of all power equipment, tree topper or trimmer when in connection with

## **Bureau County Prevailing Wage Rates posted on 4/15/2026**

construction, and diver tender.

MATERIAL TESTER/INSPECTOR I: Hand coring and drilling for testing of materials; field inspection of uncured concrete and asphalt.

MATERIAL TESTER/INSPECTOR II: Field inspection of welds, structural steel, fireproofing, masonry, soil, facade, reinforcing steel, formwork, cured concrete, and concrete and asphalt batch plants; adjusting proportions of bituminous mixtures.

### **OPERATING ENGINEERS - BUILDING (East)**

Class 1. Mechanic; Asphalt Plant; Asphalt Spreader; Autograde; Backhoes w/Caisson attachment; Batch Plant; Benoto (require 2 engineers); Boiler and Throttle Valve; Caisson Rigs; Central Redi-Mix Plant; Combination Back Hoe Front End-Loader Machine; Compressor and Throttle Valve; Concrete Breaker (Truck Mounted); Concrete Conveyor; Concrete Paver over 27E cu. ft.; Concrete Paver 27E cu.ft. and under; Concrete Placer; Concrete Pump (Truck Mounted); Concrete Tower; Cranes, All; Cranes Hammerhead; Creter Crane; Spider Crane; Crusher, Stone, etc.; Derricks, All; Derricks, Traveling; Formless Curb and Gutter Machine; Grader, Elevating; Grouting Machines; Heavy Duty Self-Propelled Transporter or Prime Mover; Highlift Shovels or Front Endloader 2-1/4 yd. and over; Hoists, Elevators, outside type rack and pinion and similar machines; Hoists, One, Two and Three Drum; Hoists, Two Tugger One Floor; Hydraulic Backhoes; Hydraulic Boom Trucks; Hydro Vac (and similar equipment); Locomotives, All; Lubrication Technician; Manipulators; Motor Patrol; Pile Drivers and Skid Rig; Post Hole Digger; Pre-Stress Machine; Pump Cretes Dual Ram; Squeeze Cretes - Screw Type Pumps; Gypsum Bulker and Pump; Roto Mill Grinder; Scoops - Tractor Drawn; Slip-Form Paver; Straddle Buggies; Operation of Tieback Machine; Tournapull; Tractor with Boom and Side Boom; Trenching Machines.

Class 2. Boilers; Brick Forklift servicing seven (7) or more Brick Masons; Broom, All Power Propelled; Bulldozers; Concrete Mixer (Two Bag and Over); Conveyor, Portable; Forklift Trucks; Highlift Shovels or Front Endloaders under 2-1/4 yd; Hoists, Automatic; Hoists, inside Freight Elevators; Hoists, Sewer Dragging Machine; Hoists, Tugger Single Drum; Hydro Excavating (excluding hose work); Laser Screed; Rock Drill (self-propelled); Non Self-Loading Ejection Dump; Rock Drill (Truck Mounted); Rollers, All; Steam Generators; Tractors, All; Tractor Drawn Vibratory Roller; Winch Trucks with "A" Frame.

Class 3. Air Compressors; Combination - Small Equipment Operator; Generators; Heaters, Mechanical; Hoists, Inside Elevators - (Rheostat Manual Controlled); Hoists, Inside Elevators; Hydraulic Power Units (Pile Driving and Extracting); Lowboys; Pumps, over 3" (1 to 3 not to exceed a total of 300 ft.); Pumps, Well Points; Welding Machines (2 through 5); Winches, 4 Small Electric Drill Winches.

Class 4. Brick Forklift; Boom Trucks (Residential); Hoists, Inside Elevators push button with automatic doors; Oilers; Skidsteer Loaders; Vacuum Trucks (excluding hose work).

Class 5. Assistant Craft Foreman

Class 6. Mechanics and Welders

Class 7. Gradall

### **OPERATING ENGINEERS - HIGHWAY CONSTRUCTION (East)**

## **Bureau County Prevailing Wage Rates posted on 4/15/2026**

Class 1. Asphalt Plant; Asphalt Heater and Planer Combination; Asphalt Heater Scarfire; Asphalt Spreader; Autograder/Gomaco or other similar type machines; ABG Paver; Backhoes with Caisson Attachment; Belt Loader; Caisson Rigs; Car Dumper; Central Redi-Mix Plant; Combination Backhoe Front Endloader Machine; Concrete Breaker (Truck Mounted); Concrete Conveyor; Concrete Paver over 27E cu. ft.; Concrete Placer; Concrete Tube Float; Cranes, all attachments; Cranes, Tower of all types; Creter Crane; Spider Crane; Crusher, Stone, etc.; Derricks, All; Derrick Boats; Derricks, Traveling; Dredges; Elevators, Outside Type Rack & Pinion and Similar Machines; Formless Curb and Gutter Machine; Grader, Elevating; Grader, Motor Grader, Motor Patrol, Auto Patrol, Form Grader, Pull Grader, Subgrader; Guard Rail Post Driver Truck Mounted; Heavy Duty Self-Propelled Transporter or Prime Mover; Hoists, One, Two and Three Drum; Hydraulic Backhoes; Locomotives, All; Backhoes with Shear Attachments; Lubrication Technician; Manipulators; Mucking Machine; Pile Drivers and Skid Rig; Pre-Stress Machine; Pump Cretes Dual Ram; Rock Drill-Crawler or Skid Rig; Rock Drill - Truck Mounted; Roto Mill Grinder; Slip-Form Paver; Snow Melters; Soil Test Drill Rig (Truck Mounted); Straddle Buggies; Hydraulic Telescoping Form (Tunnel); Operation of Tieback Machine; Tractor Drawn Belt Loader; Tractor Drawn Belt Loader with attached pusher; Tractor with Boom; Tractaire with Attachments; Transfer Barrier Transfer Machine; Trenching Machine; Truck Mounted Concrete Pump with Boom; Raised or Blind Hole Drills (Tunnel Shaft); Underground Boring and/or Mining Machine; Wheel Excavator; Widener (APSCO).

Class 2. Batch Plant; Bituminous Mixer; Boiler and Throttle Valve; Bulldozers; Car Loader Trailing Conveyors; Combination Backhoe Front Endloader Machine (less than 1 cu. yd. Backhoe Bucket or over or with attachments); Compressor and Throttle Valve; Compressor, Common Receiver (3); Concrete Breaker or Hydro Hammer; Concrete Grinding Machine; Concrete Mixer or Paver 7S Series to and including 27 cu. ft.; Concrete Spreader; Concrete Curing Machine, Burlap Machine, Belting Machine and Sealing Machine; Concrete Wheel Saw; Conveyor Muck Cars (Haglund or Similar Type); Drills, All; Finishing Machine - Concrete; Forklifts; Highlift Shovels or Front Endloader; Hoist - Sewer Dragging Machine; Hydraulic Boom Trucks (All Attachments); Hydro-Blaster (requires 2 operators; one being Class 4); Hydro Excavating (excluding hose work); Laser Screed; Locomotives, Dinky; Oil Distributor; Off-Road Hauling Units (Including Articulating); Non Self-Loading Ejection Dump; Pump Cretes; Squeeze Cretes - Screw Type Pumps, Gypsum Bulker and Pump; Roller, Asphalt; Rotary Snow Plows; Rototiller, Seaman, etc., Self-Propelled; Self-Propelled Compactor; Spreader - Chip - Stone, etc.; Scraper; Scraper - Prime Mover in Tandem; Tractors, Push, Pulling Sheeps Foot, Disc, Compactor, etc.; Tug Boats; Mechanic Welders working in permanent shop.

Class 3. Boilers; Brooms, All Power Propelled; Cement Supply Tender; Compressor, Common Receiver (2); Concrete Mixer (Two Bag and Over); Conveyor, Portable; Farm-Type Tractors Used for Mowing, Seeding, etc.; Grouting Machine; Hoists, Automatic; Hoists, All Elevators; Hoists, Tugger Single Drum; Jeep Diggers; Low Boys; Pipe Jacking Machine; Post-Hole Digger; Power Saw, Concrete Power Driven; Pug Mills; Rollers, other than asphalt; Seed and Straw Blower; Steam Generators; Stump Machine Heaters, Mechanical; Winch Trucks with "A" Frame; Work Boats; Tamper - Form - Motor Driven.

Class 4. Air Compressor; Brick Forklifts (Servicing Seven (7) or more Brick Masons; Combination - Small Equipment Operator; Directional Boring Machine; Generators; Heaters, Mechanical; Hydraulic Power Unit (Pile Driving, Extracting, or Drilling); Hydro-Blaster (requires 2 operators - one being class 2); Light Plants, All (1 through 5); Pumps, over 3" (1 to 3 not to exceed a total of 300 ft.); Pumps, Well Points; Tractaire; Vacuum Trucks (excluding hose work); Welding Machines (2 through 5); Winches, 4 Small Electric Drill Winches.

Class 5. Brick Forklifts; Oilers; Skidsteer Loaders (All).

## **Bureau County Prevailing Wage Rates posted on 4/15/2026**

Class 6. Field Mechanics and Field Welders.

Class 7. Dowell Machine with Air Compressor; Gradall and machines of like nature.

### **OPERATING ENGINEERS - BUILDING - (West)**

Class 1. Cranes; Overhead Cranes; Gradall; All Cherry Pickers; Mechanics; Central Concrete Mixing Plant Operator; Road Pavers (27E - Dual Drum - Tri Batchers); Blacktop Plant Operators and Plant Engineers; 3 Drum Hoist; Derricks; Hydro Cranes; Shovels; Skimmer Scoops; Koehring Scooper; Drag Lines; Backhoe; Derrick Boats; Pile Drivers and Skid Rigs; Clamshells; Locomotive Cranes; Dredge (all types) Motor Patrol; Power Blades - Dumore - Elevating and similar types; Tower Cranes (Crawler-Mobile) and Stationary; Crane-type Backfiller; Drott Yumbo and similar types considered as Cranes; Caisson Rigs; Dozer; Tournadozer; Work Boats; Ross Carrier; Helicopter; Tournapulls - all and similar types; Scoops (all sizes); Pushcats; Endloaders (all types); Asphalt Surfacing Machine; Slip Form Paver; Rock Crusher; Heavy Equipment Greaser; CMI, CMI Belt Placer, Auto Grade & 3 Track and similar types; Side Booms; Multiple Unit Earth Movers; Creter Crane; Trench Machine; Pump-crete-Belt Crete-Squeeze Cretes-Screw-type Pumps and Gypsum; Bulker & Pump - Operator will clean; Formless Finishing Machine; Flaherty Spreader or similar types; Screed Man on Laydown Machine; Wheel Tractors (industrial or Farm-type w/Dozer-Hoe-Endloader or other attachments); F.W.D. & Similar Types; Vermeer Concrete Saw.

Class 2. Dinkeys; Power Launches; PH One-pass Soil Cement Machine (and similar types); Pugmill with Pump; Backfillers; Euclid Loader; Forklifts; Jeeps w/Ditching Machine or other attachments; Tuneluger; Automatic Cement and Gravel Batching Plants; Mobile Drills (Soil Testing) and similar types; Gurries and Similar Types; (1) and (2) Drum Hoists (Buck Hoist and Similar Types); Chicago Boom; Boring Machine & Pipe Jacking Machine; Hydro Boom; Dewatering System; Straw Blower; Hydro Seeder; Assistant Heavy Equipment Greaser on Spread; Tractors (Track type) without Power Unit pulling Rollers; Rollers on Asphalt -- Brick Macadem; Concrete Breakers; Concrete Spreaders; Mule Pulling Rollers; Center Stripper; Cement Finishing Machines & CMI Texture & Reel Curing Machines; Cement Finishing Machine; Barber Green or similar loaders; Vibro Tamper (All similar types) Self-propelled; Winch or Boom Truck; Mechanical Bull Floats; Mixers over 3 Bag to 27E; Tractor pulling Power Blade or Elevating Grader; Porter Rex Rail; Clary Screed; Truck Type Hoptoe Oilers; Fireman; Spray Machine on Paving; Curb Machines; Truck Crane Oilers; Oil Distributor; Truck-Mounted Saws; Directional boring machine.

Class 3. Air Compressor; Power Subgrader; Straight Tractor; Trac Air without attachments; Herman Nelson Heater, Dravo, Warner, Silent Glo, and similar types; Roller: Five (5) Ton and under on Earth or Gravel; Form Grader; Crawler Crane & Skid Rig Oilers; Freight Elevators - permanently installed; Pump; Light Plant; Generator; Conveyor (1) or (2) - Operator will clean; Welding Machine; Mixer (3) Bag and Under (Standard Capacity with skip); Bulk Cement Plant; Oiler on Central Concrete Mixing Plant; Straight framed articulating end dump vehicle; Truck mounted vac unit (separately powered).

### **OPERATING ENGINEERS - HEAVY AND HIGHWAY CONSTRUCTION - (West)**

CLASS 1. Cranes; Hydro Cranes; Shovels; Crane Type Backfiller; Tower, Mobile, Crawler, & Stationary Cranes; Derricks; Hoists (3 Drum); Draglines; Drott Yumbo & Similar Types considered as Cranes; 360 Degree Swing Excavator (Shears, Grapples, Movacs, etc.); Back Hoe; Derrick Boats; Pile Driver and Skid Rigs; Clam Shell; Locomotive - Cranes; Road Pavers - Single Drum - Dual Drum - Tri Batcher; Motor Patrols & Power Blades - Dumore - Elevating & Similar Types; Mechanics; Central Concrete Mixing Plant Operator; Asphalt Batch Plant Operators and Plant Engineers; Gradall; Caisson Rigs; Skimmer Scoop - Koehring Scooper; Dredges

## **Bureau County Prevailing Wage Rates posted on 4/15/2026**

(all types); Hoptoe; All Cherry Pickers; Work Boat; Ross Carrier; Helicopter; Dozer; Tournadozer; Tournapulls - all and similar types; Operation of Concrete and all Recycle Machines; Multiple Unit Earth Movers; Scoops (all sizes); Pushcats; Endloaders (all types); Asphalt Surfacing Machine; Slip Form Paver; Rock Crusher; Operation of Material Crusher, Screening Plants, and Tunnel Boring Machine; Heavy Equipment Greaser (top greaser on spread); CMI, Auto Grade, CMI Belt Placer & 3 Track and Similar Types; Side Booms; Asphalt Heater & Planer Combination (used to plane streets); Wheel Tractors (with Dozer, Hoe or Endloader Attachments); CAT Earthwork Compactors and Similar Types; Blaw Knox Spreader and Similar Types; Trench Machines; Pump Crete - Belt Crete - Squeeze Crete - Screw Type Pumps and Gypsum (operator will clean); Creter Crane; Operation of Concrete Pump Truck; Formless Finishing Machines; Flaherty Spreader or Similar Types; Screed Man on Laydown Machine; Vermeer Concrete Saw; Operation of Laser Screed; Span Saw; Dredge Leverman; Dredge Engineer; Lull or Similar Type; Hydro-Boom Truck; Operation of Guard Rail Machine; and Starting Engineer on Pipeline or Construction (11 or more pieces) including: Air Compressor (Trailer Mounted), All Forced Air Heaters (regardless of Size), Water Pumps (Greater than 4-1/2" or Total Discharge Over 4-1/2"), Light Plants, Generators (Trailer Mounted - Excluding Decontamination Trailer), Welding Machines (Any Size or Mode of Power), Conveyor, Mixer (any size), Stud Welder, Power Pac, etc, and Ground Heater (Trailer Mounted).

CLASS 2. Bulker & Pump; Power Launches; Boring Machine & Pipe Jacking Machine; Dinkeys; Operation of Carts, Powered Haul Unit for a Boring Machine; P & H One Pass Soil Cement Machines and Similar Types; Wheel Tractors (Industry or Farm Type - Other); Back Fillers; Euclid Loader; Fork Lifts; Jeep w/Ditching Machine or Other Attachments; Tunneluger; Automatic Cement & Gravel Batching Plants; Mobile Drills - Soil Testing and Similar Types; Pugmill with Pump; All (1) and (2) Drum Hoists; Dewatering System; Straw Blower; Hydro-Seeder; Bump Grinders (self-propelled); Assistant Heavy Equipment Greaser; Apsco Spreader; Tractors (Track-Type) without Power Units Pulling Rollers; Rollers on Asphalt - Brick or Macadam; Concrete Breakers; Concrete Spreaders; Cement Strippers; Cement Finishing Machines & CMI Texture & Reel Curing Machines; Vibro-Tampers (All Similar Types Self-Propelled); Mechanical Bull Floats; Self-Propelled Concrete Saws; Truck Mounted Power Saws; Operation of Curb Cutters; Mixers - Over Three (3) Bags; Winch and Boom Trucks; Tractor Pulling Power Blade or Elevating Grader; Porter Rex Rail; Clary Screed; Mule Pulling Rollers; Pugmill without Pump; Barber Greene or Similar Loaders; Track Type Tractor w/Power Unit attached (minimum); Fireman; Spray Machine on Paving; Curb Machines; Paved Ditch Machine; Power Broom; Self-Propelled Sweepers; Self-Propelled Conveyors; Power Subgrader; Oil Distributor; Straight Tractor; Truck Crane Oiler; Truck Type Oilers; Directional Boring Machine; Horizontal Directional Drill; Articulating End Dump Vehicles; Starting Engineer on Pipeline or Construction (6 -10 pieces) including: Air Compressor (Trailer Mounted), All Forced Air Heaters (regardless of Size), Water Pumps (Greater than 4-1/2" or Total Discharge Over 4-1/2"), Light Plants, Generators (Trailer Mounted - Excluding Decontamination Trailer), Welding Machines (Any Size or Mode of Power), Conveyor, Mixer (any size), Stud Welder, Power Pac, etc., and Ground Heater (Trailer Mounted).

CLASS 3. Straight Framed Truck Mounted Vac Unit (separately powered); Trac Air Machine (without attachments); Rollers - Five Ton and Under on Earth and Gravel; Form Graders; Bulk Cement Plant; Oilers; and Starting Engineer on Pipeline or Construction (3 - 5 pieces) including: Air Compressor (Trailer Mounted), All Forced Air Heaters (regardless of Size), Water Pumps (Greater than 4-1/2" or Total Discharge Over 4-1/2"), Light Plants, Generators (Trailer Mounted - Excluding Decontamination Trailer), Welding Machines (Any Size or Mode of Power), Conveyor, Mixer (any size), Stud Welder, Power Pac, etc., and Ground Heater (Trailer Mounted).

TRUCK DRIVER - BUILDING, HEAVY AND HIGHWAY CONSTRUCTION Class 1. Drivers on 2 axle trucks hauling less than 9 ton. Air compressor and welding machines and brooms, including those pulled by separate units, truck driver helpers, warehouse

## **Bureau County Prevailing Wage Rates posted on 4/15/2026**

employees, mechanic helpers, greasers and tiremen, pickup trucks when hauling materials, tools, or workers to and from and on-the-job site, and fork lifts up to 6,000 lb. capacity.

Class 2. Two or three axle trucks hauling more than 9 ton but hauling less than 16 ton. A-frame winch trucks, hydrolift trucks, vactor trucks or similar equipment when used for transportation purposes. Fork lifts over 6,000 lb. capacity, winch trucks, four axle combination units, and ticket writers.

Class 3. Two, three or four axle trucks hauling 16 ton or more. Drivers on water pulls, articulated dump trucks, mechanics and working forepersons, and dispatchers. Five axle or more combination units.

Class 4. Low Boy and Oil Distributors.

Class 5. Drivers who require special protective clothing while employed on hazardous waste work.

### **TRUCK DRIVER - OIL AND CHIP RESEALING ONLY.**

This shall encompass laborers, workers and mechanics who drive contractor or subcontractor owned, leased, or hired pickup, dump, service, or oil distributor trucks. The work includes transporting materials and equipment (including but not limited to, oils, aggregate supplies, parts, machinery and tools) to or from the job site; distributing oil or liquid asphalt and aggregate; stock piling material when in connection with the actual oil and chip contract. The Truck Driver (Oil & Chip Resealing) wage classification does not include supplier delivered materials.

### **Other Classifications of Work:**

For definitions of classifications not otherwise set out, the Department generally has on file such definitions which are available. If a task to be performed is not subject to one of the classifications of pay set out, the Department will upon being contacted state which neighboring county has such a classification and provide such rate, such rate being deemed to exist by reference in this document. If no neighboring county rate applies to the task, the Department shall undertake a special determination, such special determination being then deemed to have existed under this determination. If a project requires these, or any classification not listed, please contact IDOL at 217-782-1710 for wage rates or clarifications.

### **LANDSCAPING**

Landscaping work falls under the existing classifications for laborer, operating engineer and truck driver. The work performed by landscape plantsman and landscape laborer is covered by the existing classification of laborer. The work performed by landscape operators (regardless of equipment used or its size) is covered by the classifications of operating engineer. The work performed by landscape truck drivers (regardless of size of truck driven) is covered by the classifications of truck driver.

**Bureau County Prevailing Wage Rates posted on 4/15/2026**